



EM 1110-1-1804
1 January 2001

US Army Corps
of Engineers

ENGINEERING AND DESIGN

Geotechnical Investigations

ENGINEER MANUAL

AVAILABILITY

Electronic copies of this and other U.S. Army Corps of Engineers (USACE) publications are available on the Internet at <http://www.usace.army.mil/inet/usace-docs/>. This site is the only repository for all official USACE engineer regulations, circulars, manuals, and other documents originating from HQUSACE. Publications are provided in portable document format (PDF).

DEPARTMENT OF THE ARMY
U.S. Army Corps of Engineers
Washington, DC 20314-1000

EM 1110-1-1804

CECW-ET

Manual
No. 1110-1-1804

1 January 2001

Engineering and Design
GEOTECHNICAL INVESTIGATIONS

- 1. Purpose.** This manual establishes criteria and presents guidance for geotechnical investigations during the various stages of development for both civil and military projects.
- 2. Applicability.** This manual applies to all USACE Commands having either military or civil works responsibilities.
- 3. Distribution Statement.** This manual is approved for public release; distribution is unlimited.
- 4. Discussion.** Geotechnical investigations are made to determine those geologic, seismologic, and soils conditions that affect the safety, cost effectiveness, design, and execution of a proposed engineering project. Because insufficient geotechnical investigations, faulty interpretation of results, or failure to portray results in a clearly understandable manner may contribute to costly construction changes, postconstruction remedial work, and even failure of a structure, geotechnical investigations and subsequent reports are an essential part of all civil engineering and design projects.

FOR THE COMMANDER:



ROBERT L. DAVIS
Colonel, Corps of Engineers
Chief of Staff

CECW-ET

Manual
No. 1110-1-1804

1 January 2001

**Engineering and Design
GEOTECHNICAL INVESTIGATIONS**

Table of Contents

Subject	Paragraph	Page
Chapter 1		
Introduction		
Purpose	1-1	1-1
Applicability	1-2	1-1
References	1-3	1-1
Background	1-4	1-1
Scope of Manual	1-5	1-2
Chapter 2		
Scope of Investigations		
Background	2-1	2-1
<i>Section I</i>		
<i>Civil Works Projects</i>		
Reconnaissance and Feasibility Studies	2-2	2-1
Preconstruction Engineering and Design Studies	2-3	2-6
Construction Activities	2-4	2-13
<i>Section II</i>		
<i>Military Construction Projects</i>		
Background	2-5	2-17
Preconcept and Site Selection Studies	2-6	2-18
Concept Studies	2-7	2-18
Final Design Studies	2-8	2-19
Construction Activities	2-9	2-19
Chapter 3		
Regional Geologic and Site Reconnaissance Investigations		
Background	3-1	3-1
<i>Section I</i>		
<i>Coordination and Information Collection</i>		
Interagency Coordination and Cooperation	3-2	3-1
Survey of Available Information	3-3	3-3

Subject	Paragraph	Page
<i>Section II</i>		
<i>Map Studies and Remote Sensing Methods</i>		
Map Studies	3-4	3-3
Remote Sensing Methods	3-5	3-9
<i>Section III</i>		
<i>Field Reconnaissance and Observations</i>		
Field Reconnaissance	3-6	3-10
Observations	3-7	3-10
<i>Section IV</i>		
<i>Information Development</i>		
Summary	3-8	3-11
Chapter 4		
Surface Investigations		
Background	4-1	4-1
<i>Section I</i>		
<i>Geologic Field Mapping</i>		
Areal Mapping	4-2	4-1
Site Mapping	4-3	4-2
Construction Mapping	4-4	4-3
<i>Section II</i>		
<i>Surface Geophysical Explorations</i>		
Background	4-5	4-4
Methods	4-6	4-4
Chapter 5		
Subsurface Investigations		
Background	5-1	5-1
Location of Investigations	5-2	5-1
Protection of the Environment	5-3	5-1
<i>Section I</i>		
<i>Borings</i>		
Major Uses	5-4	5-2
Boring and Sampling Methods	5-5	5-2
Drilling in Embankments	5-6	5-8
<i>Section II</i>		
<i>Drillhole Inspection and Logging</i>		
Objectives	5-7	5-8
Soil Identification and Description	5-8	5-9
Coring	5-9	5-9

Subject	Paragraph	Page
Core Logging	5-10	5-10
Drilling Log Form and the Boring Log Data Management Program	5-11	5-14
 <i>Section III</i>		
<i>Borehole Examination and Testing</i>		
Borehole Geophysical Testing	5-12	5-14
Borehole Viewing and Photography	5-13	5-14
Borehole Camera and Borescope	5-14	5-15
Borehole TV Camera and Sonic Imagery	5-15	5-15
Alinement Surveys	5-16	5-15
 <i>Section IV</i>		
<i>Exploratory Excavations</i>		
Test Pits and Trenches	5-17	5-15
Calyx Hole Method	5-18	5-16
 <i>Section V</i>		
<i>Groundwater and Foundation Seepage Studies</i>		
General Investigation	5-19	5-16
Permeability Testing	5-20	5-17
Pressure Tests	5-21	5-21
 <i>Section VI</i>		
<i>In Situ Testing for Determining Geotechnical Properties</i>		
In Situ Testing	5-22	5-22
In Situ Tests to Determine Shear Strength	5-23	5-23
Tests to Determine In Situ Stress	5-24	5-25
Tests to Determine In Situ Deformation	5-25	5-27
Determination of Dynamic Moduli by Seismic Methods	5-26	5-29
 <i>Section VII</i>		
<i>Backfilling of Holes and Disposition of Samples and Cores</i>		
Backfilling Boreholes and Exploratory Excavations	5-27	5-30
Disposition of Soil Samples	5-28	5-30
Disposition of Rock Cores	5-29	5-30
 Chapter 6		
Large-scale, Prototype Investigations		
Prototype Test Programs	6-1	6-1
 <i>Section I</i>		
<i>Test Excavation and Fills</i>		
Accomplishments	6-2	6-1
Test Quarries	6-3	6-1
Exploratory Tunnels	6-4	6-3
Test Fills and Trial Embankments	6-5	6-3

Subject	Paragraph	Page
<i>Section II</i>		
<i>Test Grouting</i>		
Purpose	6-6	6-5
Test Grouting Practices	6-7	6-5
Test Grouting Program	6-8	6-5
Record Keeping	6-9	6-5
<i>Section III</i>		
<i>Piling Investigations</i>		
Piling Investigation Benefits	6-10	6-6
Driving Records	6-11	6-6
Load Testing	6-12	6-6
Chapter 7		
Laboratory Investigations		
Purpose	7-1	7-1
<i>Section I</i>		
<i>Test and Sample Selection</i>		
Needs for Test and Sample Selection	7-2	7-1
<i>Section II</i>		
<i>Index and Classification Tests</i>		
Soils	7-3	7-3
Rock	7-4	7-4
<i>Section III</i>		
<i>Engineering Property Tests - Soils</i>		
Background	7-5	7-5
<i>Section IV</i>		
<i>Engineering Property Tests - Rock</i>		
Background	7-6	7-6
<i>Section V</i>		
<i>Engineering Property Tests - Shales and Moisture-Sensitive Rocks</i>		
Index Testing	7-7	7-8
Swelling Properties	7-8	7-9

Appendix A
References

Appendix B
Geologic Mapping Procedures Open Excavations

Appendix C
Geologic Mapping of Tunnels and Shafts

Appendix D
Examples of Drilling Logs

Appendix E
List of Acronyms

Appendix F
Engineer Manual 1110-1-1906, Soil Sampling

Appendix G
**Penetration Resistance Test and Sampling
with a Split-Barrel Sampler**

Appendix H
**Penetration Resistance Testing with the Becker
Hammer Drill**

Chapter 1 Introduction

1-1. Purpose

This manual establishes criteria and presents guidance for geotechnical investigations during the various stages of development for civil and military projects. The manual is intended to be a guide for planning and conducting geotechnical investigations and not a textbook on engineering geology and soils exploration. Actual investigations, in all instances, must be tailored to the individual projects.

1-2. Applicability

This manual applies to all USACE Commands having either military or civil works responsibilities. The objective of Corps of Engineers Engineer Manuals (EM)¹ is to contain engineer and design technical guidance that will provide essential technical direction and application within the COE. However, an EM cannot provide the designer with two of the most vital tools essential to successful completion of a project: experience and judgement. Engineers and geologists who are just beginning their careers are strongly encouraged to seek the advice of more experienced members of their organization.

1-3. References

Standard references pertaining to this manual are listed in Appendix A. Military Standards (MIL-STD), Army Regulations (AR), Technical Manuals (TM), Engineer Regulations (ER), Engineer Manuals (EM), Engineer Pamphlets (EP), and Engineer Technical Letters (ETL) are identified in the text by the designated Government publication number or performing agency. Additional reading materials are listed in the Bibliography and are indicated throughout the manual by the principal author's last name and date of publication. Publications may be downloaded from the internet at the Corps' web page (www.usace.army.mil/inet/usace-docs/).

1-4. Background

Geotechnical investigations are performed to evaluate those geologic, seismologic, and soils conditions that affect the safety, cost effectiveness, design, and execution of a proposed engineering project. Insufficient geotechnical investigations, faulty interpretation of results, or failure to portray results in a clearly understandable manner may contribute to inappropriate designs, delays in construction schedules, costly construction modifications, use of substandard borrow material, environmental damage to the site, postconstruction remedial work, and even failure of a structure and subsequent litigation. Investigations performed to determine the geologic setting of the project include: the geologic, seismologic, and soil conditions that influence selection of the project site; the characteristics of the foundation soils and rocks; geotechnical conditions which influence project safety, design, and construction; critical geomorphic processes; and sources of construction materials. A close relationship exists between the geologic sciences and other physical sciences used in the determination of project environmental impact and mitigation of that impact. Those individuals performing geotechnical investigations are among the first to assess the physical setting of a project. Hence, senior-level, experienced personnel are required to plan and supervise the execution of a geotechnical investigation. Geotechnical investigations are to be

¹ A list of acronyms and abbreviations is included as Appendix E to this manual.

carried out by engineering geologists, geological engineers, geotechnical engineers, and geologists and civil engineers with education and experience in geotechnical investigations. Geologic conditions at a site are a major influence on the environmental impact and impact mitigation design, and therefore a primary portion of geotechnical investigations is to observe and report potential conditions relating to environmental impact. Factors influencing the selection of methods of investigation include:

- a. Nature of subsurface materials and groundwater conditions.
- b. Size of structure to be built or investigated.
- c. Scope of the investigation, e.g., feasibility study, formulation of plans and specifications.
- d. Purpose of the investigation, e.g., evaluate stability of existing structure, design a new structure.
- e. Complexity of site and structure.
- f. Topographic constraints.
- g. Difficulty of application.
- h. Degree to which method disturbs the samples or surrounding grounds.
- i. Budget constraints.
- j. Time constraints.
- k. Environment requirements/consequences.
- l. Political constraints.

1-5. Scope of Manual

Increasingly, geotechnical investigations are conducted to evaluate the condition of existing projects as part of Operations and Maintenance. This type of investigation places special constraints on the methods which may be used. These constraints should be kept in mind by the designer.

a. *General.* Geotechnical investigations for roads and airfields are not discussed. Geotechnical investigations at construction sites may involve exposure to hazardous and toxic waste materials. In cases where such materials are recognized, geotechnical investigators should contact the Mandatory Center for Expertise for assistance. It is of note that many of the techniques and procedures described in this manual are applicable to hazardous, toxic, and radioactive waste (HTRW) work. Geotechnical aspects of HTRW site assessment are discussed in Construction Site Environmental Survey and Clearance Procedures Manual (Draft), EM 1110-1-4000, Walker (1988), and Borrelli (1988).

b. *Types of detailed discussions.* Chapter 2 provides guidance on geotechnical investigations appropriate to various stages of project development. Chapter 3 provides for implementation of initial, regionally oriented geotechnical investigations. Chapter 4 provides guidance for field procedures for surface investigations. Chapter 5 provides guidance on subsurface investigation procedures. Chapter 6 describes procedures for large-scale, prototype investigations, and Chapter 7 describes laboratory

procedures for characterizing geotechnical properties of materials. Appendices and subject matter covered are: Appendix B, details for geologic mapping of construction areas; Appendix C, geologic mapping of tunnels and shafts; Appendix D, examples of drilling logs; Appendix F, soil sampling; and Appendices G and H, penetration resistance testing. Appendix F includes the modified version of the engineering manual on soil sampling. Information on soil sampling is also contained in Appendix C of EM 200-1-3. The text references specific sections of the soil sampling EM where appropriate. Guidance is in general terms where methodologies are prescribed by industry standards and described in accessible references. Where descriptions are otherwise unavailable, they are provided herein. The manual intends to provide general guidance to geotechnical investigation; because of the variability that exists among Corps of Engineers (COE) Districts or Divisions, it is advisable that each district and division prepare separate field investigations manuals. The manual should highlight procedures and formats of presentation that are preferred for geotechnical investigations within that organization. These manuals should be consistent with applicable EM.

Chapter 2 Scope of Investigations

2-1. Background

From project conception through construction and throughout the operation and maintenance phase, geotechnical investigations are designed to provide the level of information appropriate to the particular project development stage. In most instances, initial geotechnical investigations will be general and will cover broad geographic areas. As project development continues, geotechnical investigations become more detailed and cover smaller, more specific areas. For large, complex projects, the geotechnical investigation can involve highly detailed geologic mapping such as a rock surface for a structure foundation. The scope of the various increments of investigation are described in the following paragraphs. Although some material is presented in detail, rigid adherence to an inflexible program is not intended. It is the responsibility of the geotechnical personnel in the field operating activities to design individual geotechnical investigations to the particular project requirements and local conditions. However, there are minimum requirements for geotechnical investigations to be performed as part of the project development stages, and this manual serves to outline these basic standards. All geotechnical investigations should be planned and conducted by the district element having geotechnical design responsibility. No geotechnical investigation should be contracted out unless the district geotechnical design element reviews and approves the scope of work.

Section I Civil Works Projects

2-2. Reconnaissance and Feasibility Studies

a. Purpose. Reconnaissance studies are made to determine whether a problem has a solution acceptable to local interests and is in accordance with administrative policy. If so, reconnaissance studies provide information to determine whether planning should proceed to the feasibility phase (ER 1110-2-1150). Feasibility studies identify and evaluate the merits and shortcomings of environmental, economic, and engineering aspects of the proposed project. Planning guidelines for conducting these studies are contained in ER 1105-2-100. Guidelines on engineering activities during feasibility and preconstruction planning and engineering studies are provided in the 1110 series of publications.

b. Scope of geotechnical investigations. Geotechnical investigations during planning studies should be designed to provide information at a level such that critical geotechnical features of candidate sites may be compared in the feasibility study report. These investigations should be sufficiently complete to permit selection of the most favorable site areas within the regional physical setting, determine the general type of structures best suited to the site conditions, evaluate the influence of hydrogeology on site design and construction, assess the geotechnical aspects of environmental impact, and to ascertain the costs of developing the various project plans in sufficient detail to allow comparative cost estimates to be developed.

c. Investigation steps. Planning-level geotechnical investigations are generally performed in two parts: development of regional geology and initial site investigations. The regional geology investigations are carried out during early stages of the study. Initial field investigations begin after the regional studies are sufficiently detailed to identify areas requiring geotechnical clarification.

(1) Development of regional geology. Figure 2-1 is a schematic diagram showing the steps involved and data needed to evaluate the regional geology of a site. Knowledge of the regional geology is essential to preliminary planning and selection of sites and to interpretation of subsurface exploration data. With the exception of fault evaluation studies, determination of seismicity and preliminary selection of the design earthquake are performed in conjunction with evaluation of the regional geology. Much of the data needed for describing the regional geology and for determining seismicity are identical, and therefore, the efforts can be combined. Engineering seismology requirements for more in-depth studies of tectonic history, historical earthquake activity, and location of possible active faults are a logical extension of the regional geologic studies. Requirements for conducting earthquake design and analyses, including geological and seismological studies, are contained in ER 1110-2-1806.

(a) Utilization of remote sensing information in assessing the regional geology of a site can greatly increase effectiveness and reduce time and costs. Commonly, a series of remote sensing images, taken at various times, are available for a site. Remote sensing images for evaluating regional geology generally include both aerial photographs and satellite images. Remote sensing analysis can be used to evaluate geomorphic characteristics and geologic structure; map soils, sediment sources, and transport directions; and monitor and evaluate environmental impacts. Use of remote sensing for geological investigations is discussed by Gupta (1991). Remote sensing applications in desert areas are discussed by Rinker et al. (1991). Principal sources of remote sensing imagery include the U.S. Geological Survey (USGS) at 605-594-6151 (or edcwww.cr.usgs/content_products.html on the computer Internet, or World Wide Web) and U.S. Department of Agricultural (USDA) Farm Security Agency at 801-975-3503.

(b) Compiled and properly interpreted regional geologic and field reconnaissance information should be used to formulate a geologic model for each site. The use of a Geographic Information System (GIS) is highly recommended for developing this model. A GIS provides a platform in which to digitally store, retrieve, and integrate diverse forms of geo-referenced data for analysis and display. A GIS can be thought of as a high-order map that has the capability of distilling information from two or more map layers (Star and Estes 1990; Environmental Systems Research Institute (ESRI) 1992). Application of GIS to geotechnical studies enhances data management with respect to project planning/design, field work strategy, map/statistical generation, and identification/correlation of important variables. The application of a GIS to a project depends on the size and complexity of the project and the availability of usable data. Judgement is needed to evaluate the benefits of a GIS versus the high cost of initial construction of the model. A project GIS can be used by all parties (e.g., designers, engineers, geologists, archaeologists) in all phases of a project from site selection to postconstruction operations and maintenance.

(c) Whether done using a GIS or more traditional methods, the geologic model will be revised during successive investigation stages and thereby provide the information necessary to determine the scope of initial field investigations. Procedural information on the steps required to develop the regional geology and perform field reconnaissances is contained in Chapter 3.

(2) Initial field investigations. Figure 2-2 details the general procedures for initial field investigations. Areal extent of the investigations is determined by the size and nature of the project. However, each site investigation should provide information on all critical geotechnical features that influence a site. Procedural information for conducting a surface field investigation is presented in Chapter 4, and for subsurface field investigations in Chapter 5. Major projects, such as dams and reservoirs, electric generating plants, and locks and dams, require comprehensive field investigations. Procedures for carrying out such detailed investigations are discussed in Chapter 6. Areal and site geotechnical mapping allow early modification of initial geologic models and tentative layouts for

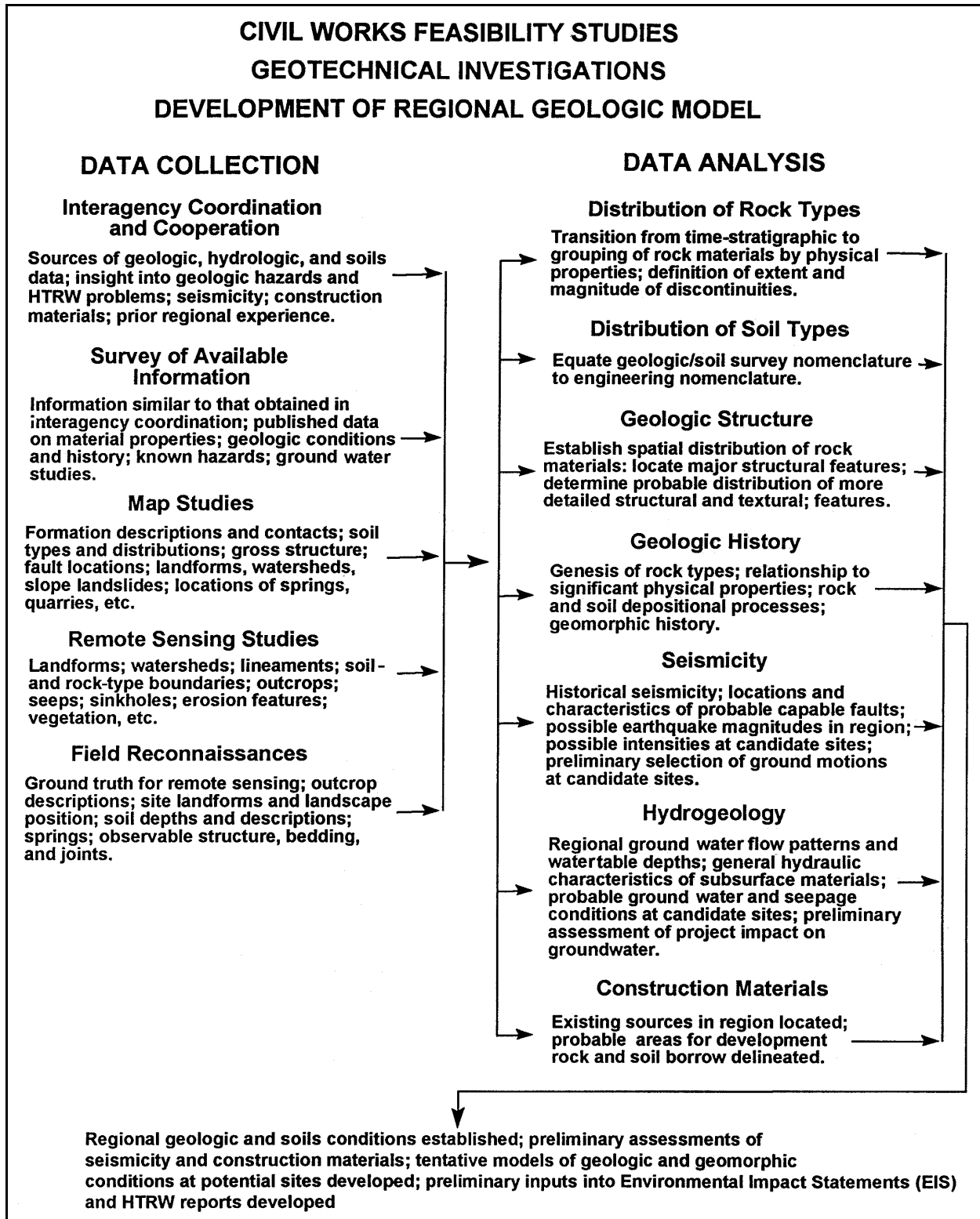

Figure 2-1. Schematic diagram of the development of regional geology

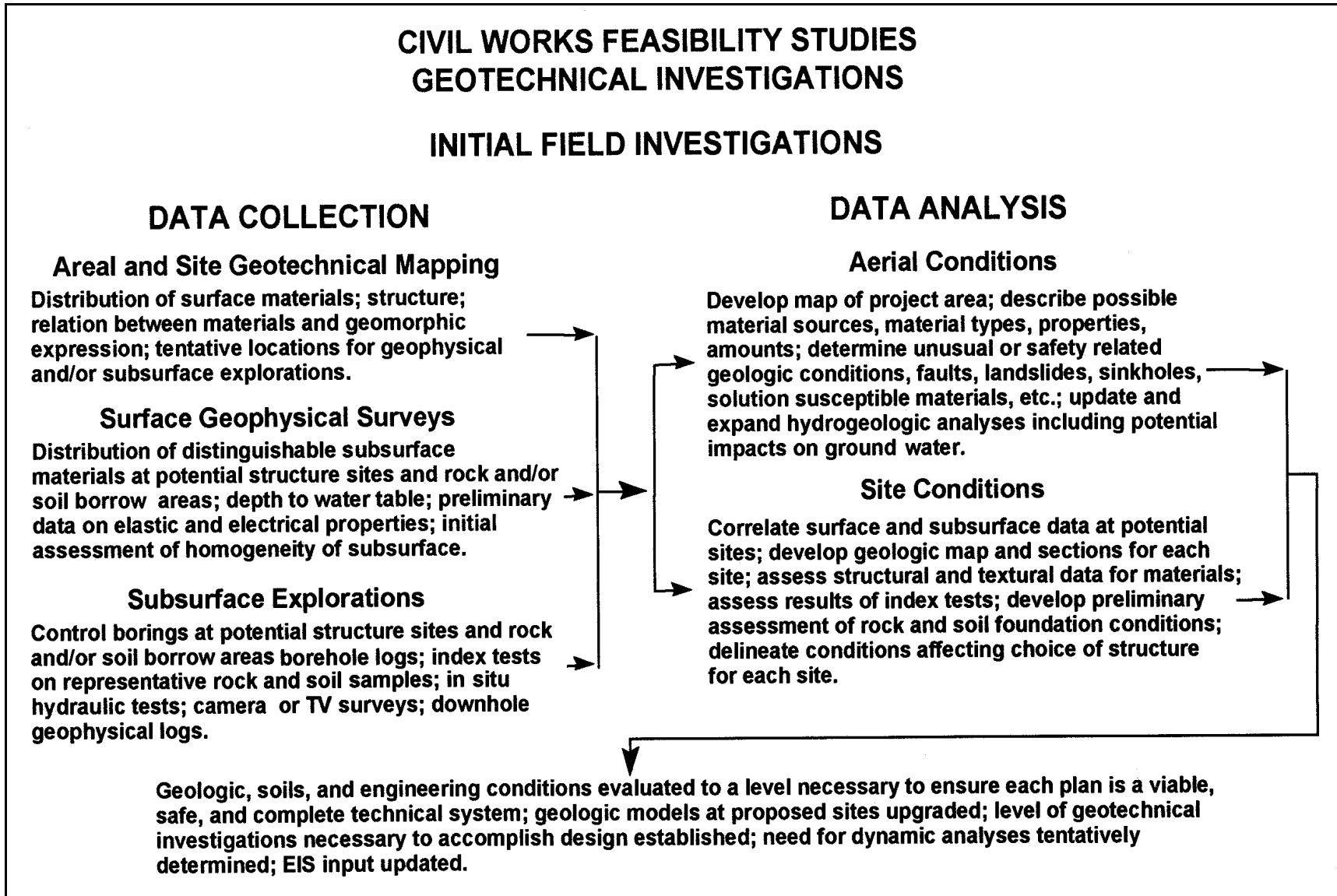

Figure 2-2. Schematic diagram of initial field investigations

surface geophysical surveys and subsurface explorations. Properly conducted surface geophysical surveys can provide information over relatively large areas on overburden depths, depth to the water table, and critical geologic contacts. Such surveys, prior to exploration drilling, can reduce the number of borings in proposed structure foundation areas and, in some cases, the number of borrow area borings. The surveys should be run along axes of potential dam sites and along canal alignment; at lock, off-channel spillways and tunnel and conduit sites; at potential borrow and quarry sites; and at locations where buried channels, caverns, or other elusive, but important, geologic conditions are suspected.

(a) Exploratory drilling is required at all sites to be included in the feasibility study. The numbers and depths of borings required to provide adequate coverage cannot be arbitrarily predetermined but should be sufficient to reasonably define the subsurface in the various site areas. Investigations necessary for levees, flood walls, pumping plants, recreation areas, and other miscellaneous structures are not as extensive as those required for major structures and projects. Generally, the scope of the regional geologic study is much reduced for projects authorized for site-specific reasons.

(b) The field investigation program should be tailored to site-specific needs. Field investigations in connection with planning of channel improvements or diversion channels should be sufficient to determine the types of materials to be excavated, hydraulic conductivity of the substrate, stability of bank slopes, and susceptibility of the substrate to scour. Assessment of channel stability for flood control projects is discussed in EM 1110-2-1418. In the case of irrigation or perched canals, seepage losses may be a significant problem. The field investigations should examine the need for an impervious lining and the availability of material for this purpose.

d. Reporting for feasibility studies. The reporting of results for feasibility in accordance with the overall study reporting requirements is contained in ER 1105-2-100. The results of all geotechnical investigations performed as part of the feasibility study efforts will be presented in detail. Sufficient relevant information on the regional and specific site geotechnical conditions must be presented to support the rationale for plan selection, project safety, environmental assessments including HTRW potential, and preliminary project design and cost estimates. This information should be presented in summary form in the feasibility report and in sufficient detail in appendices to allow evaluation and review.

(1) The feasibility report should contain summaries of the regional geology, soils, hydrogeology, and seismological conditions plus brief summaries of the areal and site geotechnical conditions for each detailed plan. These summaries should include local topography, geomorphic setting and history, thickness and engineering character of overburden soils, description of rock types, geologic structure, degree of rock weathering, local ground water conditions, possible reservoir rim problems, description of potential borrow areas and quarries, accessibility to sources of construction materials, and potential for HTRW sites. In addition, special foundation conditions such as excavation or dewatering problems, low-strength foundations, and cavernous foundation rock should be described. The summaries should conclude with a discussion of the relative geotechnical merits and drawbacks of each plan.

(2) Discussions of the regional geology and initial field investigations should be presented in an appendix on engineering investigations. The content of the discussion on regional geology should include the items outlined in Figure 2-1. In addition, a discussion of topography should be included. Drawings should be used to explain and augment the detailed discussion of regional geology. As a minimum, the drawings should include a regional geology map, regional geologic sections showing the spatial relationship of rock units and major geologic structures, a regional lineament map, and a map of recorded and observed seismic events (epicenter map). Dearman (1991) describes the principles of

engineering geologic mapping. Because summaries of areal and site geotechnical conditions for each detailed plan will be included in the feasibility report, the detailed discussion of areal and site geology, foundation conditions, and problems presented in the appendix may be limited to the recommended detailed plan. Figure 2-2 contains much of the information which should be included in the detailed discussion of areal and site geotechnical conditions. The discussion should indicate the sources from which information was obtained and will include the following items:

- (a) Types of investigations performed.
- (b) Areal and site geology (including topography of site or sites).
- (c) Engineering characteristics of soil, rock, foundation, and reservoir conditions.
- (d) Mineral deposits.
- (e) Potential borrow and quarry sites.
- (f) Available construction materials.
- (g) Conclusions and recommendations.
- (h) Graphics.

2-3. Preconstruction Engineering and Design Studies

a. Purpose. Preconstruction engineering and design (PED) studies are typically initiated after a feasibility study has been completed. PED studies are developed to reaffirm the basic planning decisions made in the feasibility study, establish or reformulate the scope of the project based on current criteria and costs, and formulate the design memoranda which will provide the basis for the preparation of plans and specifications. Figure 2-3 schematically outlines the engineering tasks for the PED studies with the requirements for geotechnical information.

b. Scope of geotechnical investigations. Geotechnical investigations performed during the PED studies should be in sufficient detail to assure that authorized measures can be implemented. The emphasis is toward site-specific studies which will provide the detail and depth of information necessary to select the most suitable site and structures to achieve project goals. The studies are performed in a series of incremental steps of increasing complexity beginning with the site selection study on major projects and continuing through feature design studies. Geotechnical procedures for performing field and laboratory investigations for these studies are found in Chapters 4 through 7.

c. Site selection study. This study serves to provide criteria for selecting the most appropriate site for the authorized project.

(1) Preliminary. The initial phase of the PED should begin with a comprehensive review of all geotechnical studies made during the feasibility study period. If there is a significant gap in time between the feasibility and PED studies, considerable geotechnical information may have been generated, compiled, analyzed, and published by Federal and State geotechnical agencies. These data should be obtained and correlated with the completed studies for evidence of significant changes in the geological knowledge of the study region. This is particularly important in the disciplines of seismology and hydrogeology.

CIVIL WORKS DESIGN MEMORANDUM STUDIES GEOTECHNICAL INVESTIGATIONS

Purpose and Scope

Perform all engineering, design, and reporting for the authorized plan. Serve as a basis for preparation of constructions, plans, and specifications. Primarily concerned with the functional and technical design of structures necessary to achieve project objectives with the development of plans and specifications.

TASKS

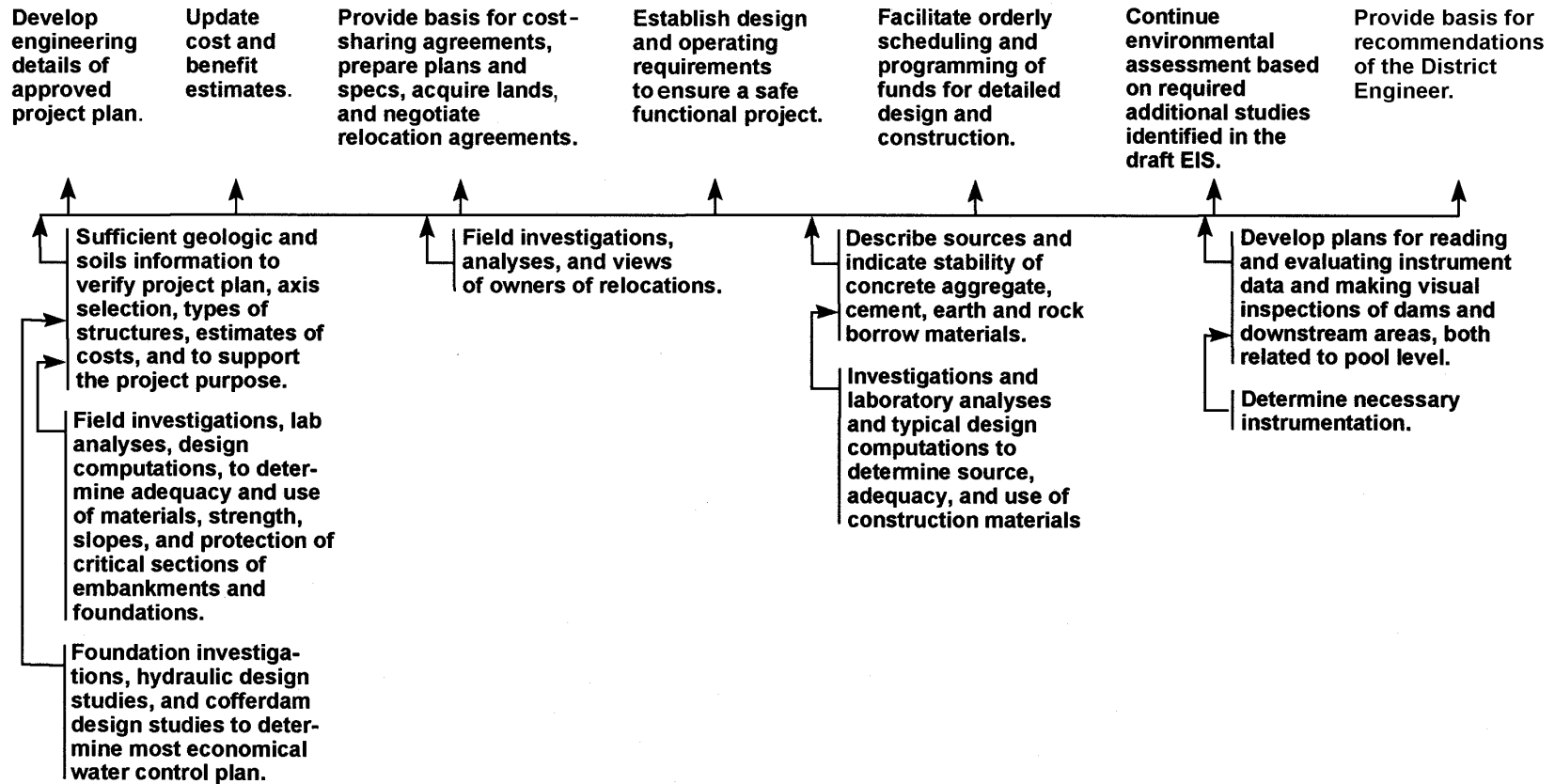

Figure 2-3. Outline of preconstruction engineering and design studies

(2) Data collection. In the case of major projects such as dams, powerhouses, and navigation structures, some latitude normally exists in the proposed locations of the structures. At this stage, possible structure sites that would serve the intended project purposes should be evaluated before selecting a field investigations program. Geologic and hydraulic information collected during the feasibility study is generally sufficient for this purpose. After the obviously poor sites have been eliminated, a field investigation program should be developed. The type of data and collection methodology are outlined schematically in Figure 2-4. The investigation program should emphasize the completion of surface geologic mapping, expansion of surface geophysical surveys, detailed remote sensing analysis, and broadening of the scope of ground water investigations. Sufficient borings should be made at each potential site so that correlation of surface mapping and geophysical surveys is reasonably accurate. Use of the cone penetrometer and standard penetrometer test methods as part of a subsurface investigation program should be evaluated where geologic conditions are appropriate for these and subsequently more complex site studies. Subsurface sampling should be comprehensive to the point where laboratory indexing of engineering properties of soils and rock types, where appropriate, can be accomplished. Earthquake engineering analyses should be made if the seismicity studies made during the feasibility study indicate their need. At this time, a preliminary seismic evaluation should be made of the proposed structures and trenching performed if local active faulting is identified. The end result should be that areal and site geotechnical conditions are defined to the extent necessary to support design studies needed for reliable cost estimates. Data on proposed sites should be sufficiently complete to fully consider the effects of geotechnical conditions on site selection.

(3) Reporting site selection studies. The reporting of results of site selection studies will be in accordance with ER 1110-2-1150. The site selection design memorandum may be a separate document prepared prior to the PED for complex projects, or may be submitted as a major appendix to the PED. The content of the Site Selection Memorandum will include the items shown in Figure 2-4. Discussions will be augmented by geologic maps and profiles, boring logs, and laboratory and geophysical data all presented at a readable scale. The recommended site must be validated by sufficient geotechnical information in light of current conditions and criteria to avert reformulation of the project during the PED studies because of geotechnical problems.

d. Design investigations. Upon commencement of final design investigations, all previous engineering and design reports for the selected plan are carefully reviewed before initiating additional field investigations. These efforts provide information to support cost estimate decisions regarding the functional and technical design of structures necessary to achieve project objectives and development of construction plans and specifications. Design investigation tasks are outlined schematically in Figure 2-5 and are discussed in the following text.

(1) Preliminary. Upon commencement of the design investigations (postsite selection), all regional and site-specific geotechnical data should be reviewed before commencement of field investigations. New data, particularly that generated by other agencies, both Federal and state, should be obtained and incorporated into the original data base.

(2) Data collection. The foundation and design data collection activities are iterative, developing greater detail as the project design progresses toward the preparation of plans and specifications.

(a) PED data collection. In general, a closer order of subsurface investigations is then used in site selection studies. Where soils strongly influence the foundation design, undisturbed soil sampling should be initiated or expanded to classify and index their engineering properties in more comprehensive detail (Cernica 1993). Rock types and conditions, geologic structure, and engineering properties should

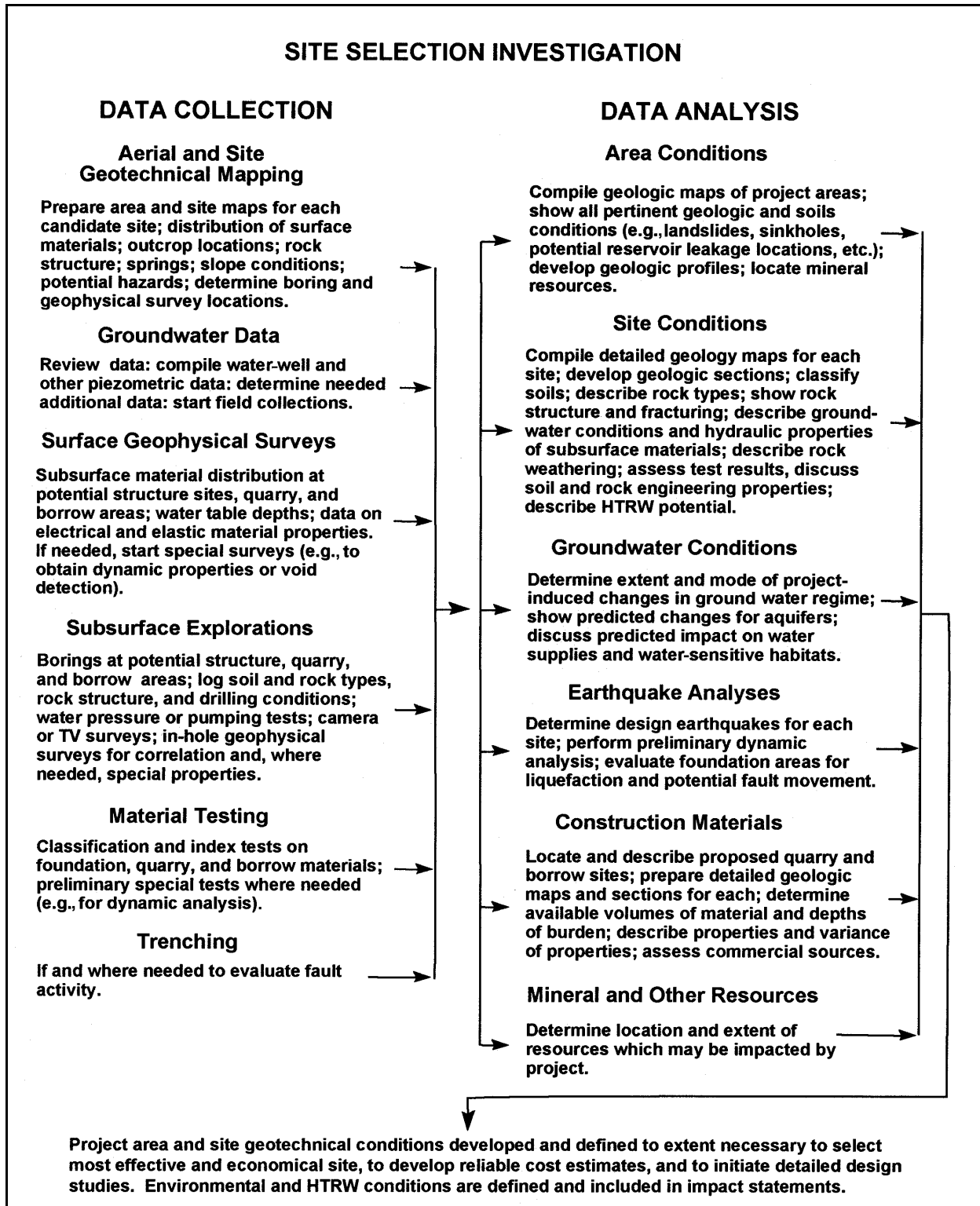

Figure 2-4. Schematic diagram on development of site selection investigations, general design memorandum (GDM)

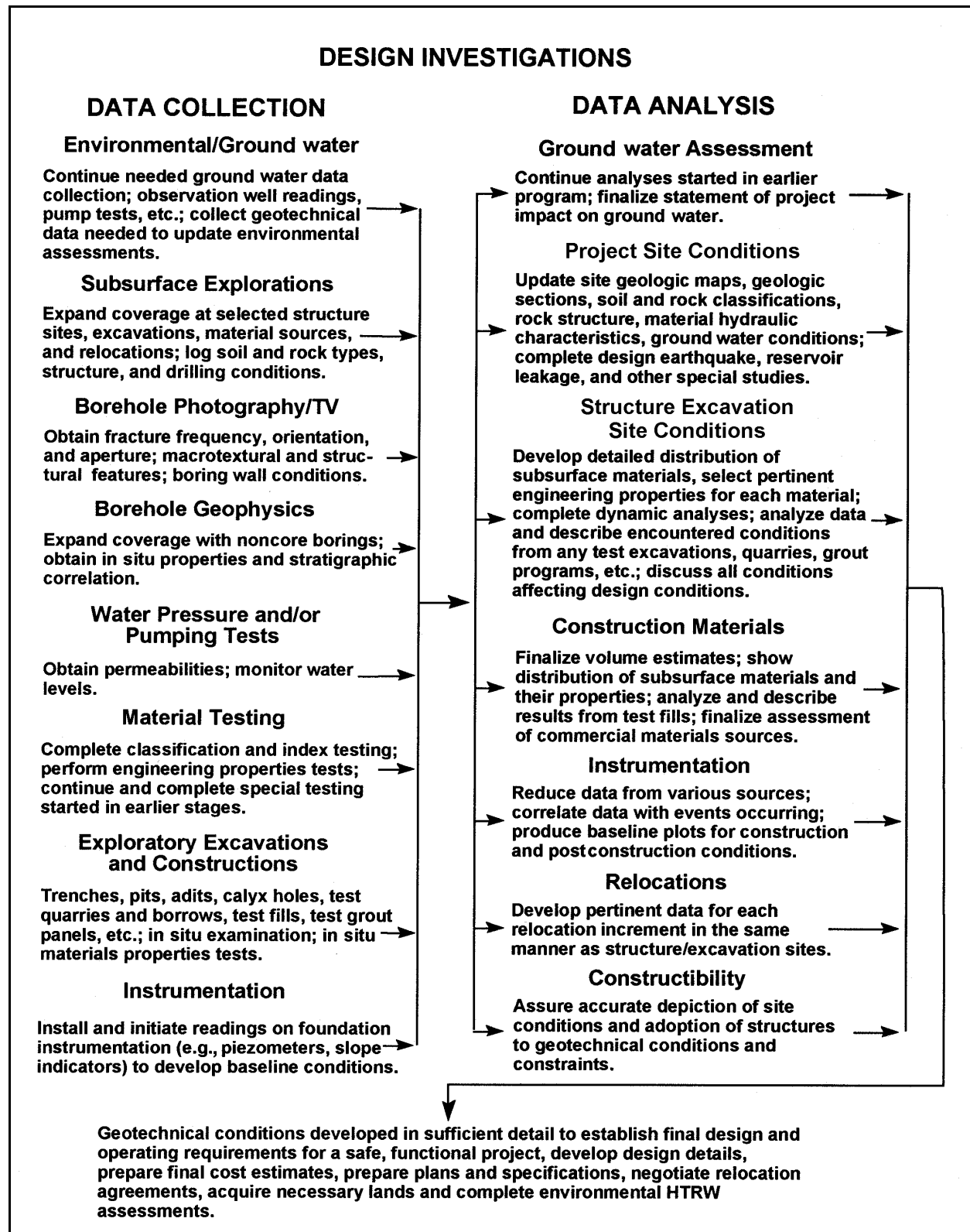

Figure 2-5. Schematic diagram for design investigations for postsite studies

be defined to the extent necessary to design foundation treatment. In the case of water-retention structures, pump and/or pressure tests should be performed. Installation of observation wells and piezometers should be initiated early in the investigations so that seasonal variation in ground water levels can be observed. Geophysical studies should be expanded to include crosshole surveys. Regional ground water and earthquake engineering analyses should be completed. Upon completion of the PED studies, geotechnical conditions should be developed in sufficient detail to establish design and operating requirements for a safe, functional project. If the overall project scope is such that feature design memoranda are not prepared, the geologic and soils information should be sufficient to support the preparation of plans and specifications.

(b) Feature design data collection. Following the PED study, project complexity and size will frequently require separate feature design memoranda on such structures as concrete dams, navigation locks, outlet works, road relocation, and other similar project features. Generally, each special memorandum requires a geotechnical investigation. The investigation is an extension of previous studies but focuses on the area surrounding the structure under study. These studies are expanded by close-order subsurface investigations which may include large-diameter borings, cone penetrometer or standard penetrometer tests, test excavations, fills, and grouting programs, detailed laboratory testing, pile driving and load tests, and any other method of investigations which will resolve issues or problems that came to light during the PED study. Such issues and problems may include detailed evaluation of underseepage, dynamic response, and stability. For major projects requiring large amounts of concrete and/or protection stone, separate feature design memoranda specific to these materials should be prepared. This investigation is started during the initial study period and completed early in the feature design study so that the major structure requiring the materials can be properly designed. At the completion of the FDM studies, all geotechnical features and problems should have been identified and resolved. The final design, incorporating the geological conditions encountered at the sites and identifying the selected geotechnical design parameters, will be complete so that preparation of plans and specifications for construction of the project can proceed.

(3) Design investigations reports. Reporting results of design investigations will be in accordance with the overall reporting requirements contained in ER 1110-2-1150. In many cases, project complexity and size will require that the design investigations be reported in the general design memorandum (GDM) and an orderly series of feature design memoranda (FDM). This information provides the basis for constructibility assessment and formulation of the final design and preparation of the construction plans and specifications.

(a) GDM. The results of all foundation and design investigations performed as part of the project engineering studies will be summarized in the GDM and presented in detail in appendices to that report. The updated regional geology, engineering seismology, hydrogeology, and earthquake engineering studies should be thoroughly documented. As previously stated, if a separate report has not been prepared, the site selection studies should be presented as an appendix to the GDM. If FDM are not prepared, the geologic and soils information in the PED should be sufficient to support the preparation of plans and specifications. Discussions should be augmented by geologic maps and profiles, boring logs, laboratory and geophysical data, and special studies relating to seismology, ground water, and construction materials.

(b) FDM. The geotechnical discussion that will be included in the various FDM which discuss geological aspects of the project should be similar in scope to that presented in the GDM. However, only geotechnical data that clarify the particular intent of the FDM will be used. The discussion will be augmented by the appropriate geologic maps and profiles, boring logs, and laboratory and geophysical

data. The design memoranda that are distinctly geotechnical or have geotechnical input of significant importance include:

- (i) Site geology.
- (ii) Concrete materials or protection stone.
- (iii) Embankment and foundation.
- (iv) Outlet works.
- (v) Spillway.
- (vi) Navigation lock.
- (vii) Instrumentation and inspection program.
- (viii) Initial reservoir filling and surveillance plan.
- (ix) Intake structure.
- (x) Relocations (roads and bridges).

e. Formulation and evaluation of construction plans and specifications.

(1) Biddability, constructibility, and operability review. Constructibility review is performed in accordance to ER 415-1-11. Constructibility studies evaluate compatibility of design, site, materials, techniques, schedules, and field conditions; sufficiency of details and specifications; and freedom from design errors, omissions, and ambiguities. District offices will coordinate project review by geotechnical, construction, and engineering personnel to improve the constructibility of design. The review process should occur during the development of the draft plans and specifications and, therefore, not be responsible for major changes in foundation and embankment design, instrumentation, or other geotechnically related features which could impact on the project schedule.

(2) Preparation of plans and specifications. Plans and specifications will be prepared in accordance with ER 1110-2-1200. The plans and specifications will contain an accurate depiction of site conditions and will be carefully prepared to eliminate or depict conditions which might delay the work or be grounds for claims. Plans and specifications will contain a thorough graphic presentation of all borings made in the area under contract. All boring locations will be shown. Factual data representing field surveys such as geophysical and hydrological investigations shall be presented in a usable form, preferably a GIS format. Because of the voluminous nature of laboratory data, these data not presented with the borings or tabulated elsewhere must be indicated as available to all prospective contractors. Other data in this category could include mapping data, photographs, and previously published geologic reports and design documents.

(3) Geotechnical design summary report. For some projects where geotechnical considerations are of paramount importance, a geotechnical design summary report may be prepared and included with the bid documents. Disclosure of the design assumptions and interpretations of data in this type of document often serve to clarify intent during the construction of a project.

2-4. Construction Activities

a. Purpose. In some cases, construction activities such as test fills or test excavations are performed to prepare plans and specifications that are compatible with the project design. These plans and specifications are to assure construction quality and document actual construction conditions.

b. Scope of geotechnical activities. Geotechnical activities in support of the construction phase of a project can be divided into three phases: construction management, quality assurance, and compilation of summary reports.

c. Execution of geotechnical construction activities. Guidelines for conducting construction activities are contained in the following Engineering Regulations: ER 415-2-100, ER 1110-2-1200, ER 1110-2-1925, and ER 1180-1-6. Construction activities are summarized in Figure 2-6 and discussed as follows:

(1) Construction management. Construction management and policies are performed in accordance with ER 415-2-100. It is the goal of the Corps of Engineers to construct and deliver a quality product. The key to obtaining this objective is an effective construction management system staffed by an adequate number of trained and competent personnel. Areas of expertise shall be appropriate to the type of construction project under contract and can include, but not be limited to, foundation preparation, rock and soil excavation, embankment and concrete control and emplacement, and grouting.

(a) Claims and modifications. Regardless of the intensity of geological investigations during the preconstruction phase, differing site conditions, claims, and modifications are to be expected on complex projects. Therefore, engineering should provide necessary support to investigate claims and provide design and cost-estimating assistance for any claims and modifications.

(b) Site visits for verification of quality. On all projects, but especially those too small to support a resident geologist or geotechnical engineer, site visits should be made regularly by qualified personnel to verify that conditions match assumptions used in designing the project features and to assist construction personnel on any issues affecting construction. All visits should be well documented (including an extensive photographic and video record) and be included in appropriate summary reports.

(2) Quality assurance and management. Quality assurance, which is the responsibility of the Government, will be performed in accordance with ER 1180-1-6. The geotechnical staff members assigned to the project have the responsibility to monitor, observe, and record all aspects of the construction effort relating to foundations, embankments, cuts, tunnels, and natural construction materials. Figure 2-7 shows in tabulated form some of the particular items requiring quality assurance particular to geotechnically oriented features.

(a) Quality assurance testing will be performed to assure acceptability of the completed work and verify quality control test procedures and results. An onsite laboratory should be required on major projects to perform all soil and concrete testing. During construction, considerable data are assembled by the project geotechnical quality assurance staff. These data consist generally of foundation mapping and treatment features, embankment-backfill performance data, grouting records, material testing data, pile driving records, and instrumentation results. Special treatment and problem areas, often requiring contract modification, should be well documented.

CIVIL WORKS CONSTRUCTION CONSTRUCTIBILITY, QUALITY MANAGEMENT, AND DOCUMENTATION

Purpose and Scope

Require the highest order of engineering and technique in the performance of work. Assure compatibility of personnel, design, site, materials, methods, techniques, schedules, and field conditions. Assure sufficiency of details and specifications and freedom from design errors, omissions, and ambiguities. Assure that construction is completed in a timely manner and meets all requirements of the contract. Ensure the preservation for future use of complete records of foundation conditions encountered during construction and of methods used to adapt structures to these conditions. Provide significant information needed to become familiar with the project, reevaluate the embankment in case of unsatisfactory performance, and provide guidance for designing future projects.

TASKS

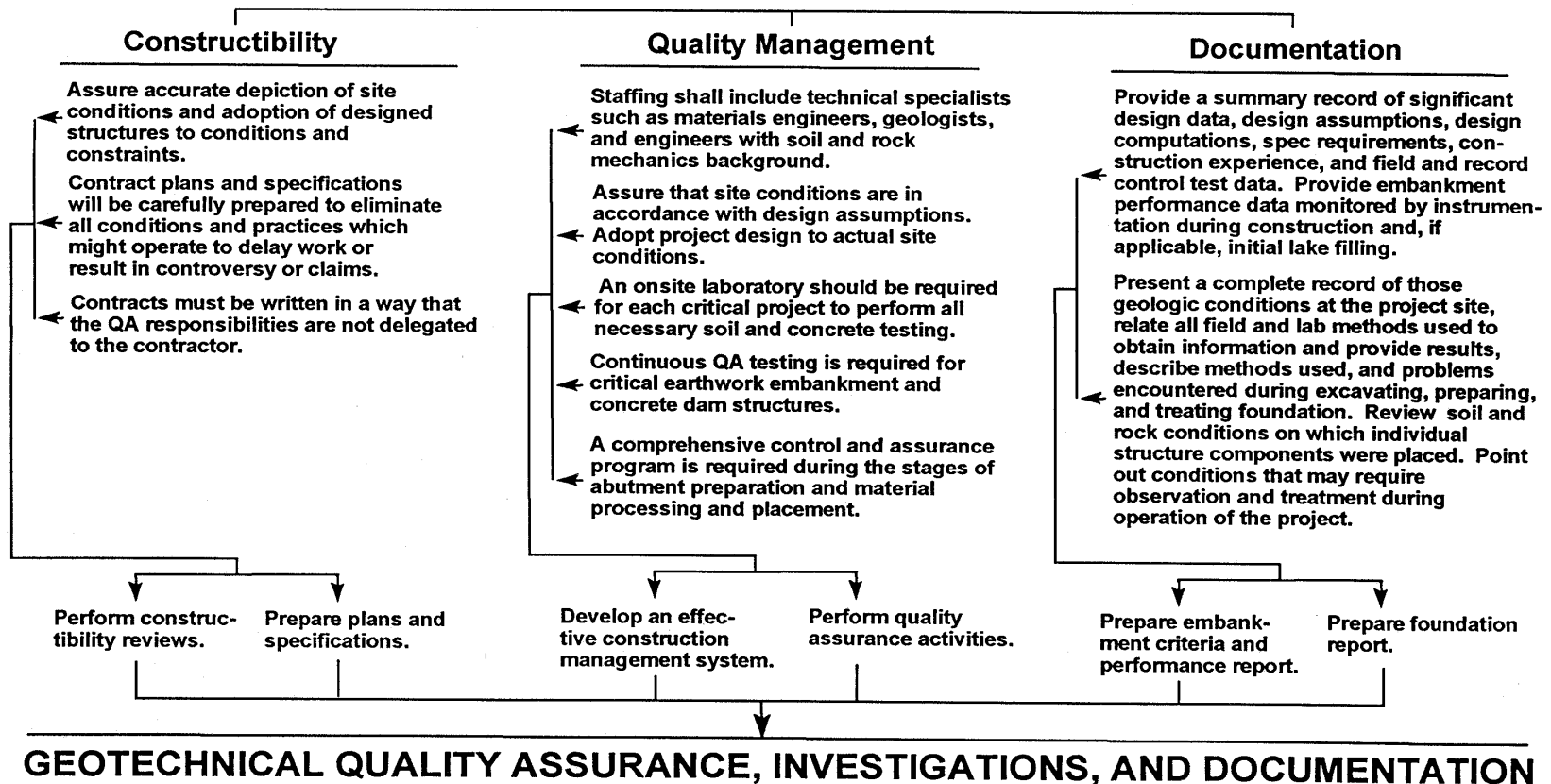

Figure 2-6. Outline of tasks for construction geotechnical activities

CIVIL WORKS CONSTRUCTION CONSTRUCTIBILITY, QUALITY MANAGEMENT, AND DOCUMENTATION		
QUALITY ASSURANCE OF GEOTECHNICAL ACTIVITIES		
<u>Excavation Procedures</u>	<u>Foundation/Abutment Treatment</u>	<u>Embankment/Backfill</u>
<ul style="list-style-type: none"> Grades Unwatering Overburden Rock <ul style="list-style-type: none"> Blast patterns/procedures Fragmentation Control of wall rock damage Slope stability Support Preliminary cleanup Surface protection 	<ul style="list-style-type: none"> Subsurface <ul style="list-style-type: none"> Curtain grouting Area grouting Consolidation grouting Caissons, trenches, slurry walls, etc. Surface <ul style="list-style-type: none"> Final cleanup Dental concrete Shotcrete Slurry grouting Drainage <ul style="list-style-type: none"> Adits Drain holes Relief wells 	<ul style="list-style-type: none"> Material source Material placement Control tests Slope stability Seepage control Diversion and closure

Figure 2-7. Critical geotechnical activities that require carefully outlined quality assurance procedures

(b) Early in the construction of the project, the geotechnical staff should develop a data analysis and storage system, preferably one which can be used to monitor construction activities. The Grouting Database Package (Vanadit-Ellis et al. 1995) is a personal computer (PC)-based, menu-driven program that stores and displays hole information, drilling activities, water pressure tests, and field grouting data. Instrumentation Database Package (Woodward-Clyde Consultants 1996) is a menu-driven, PC Windows-based program that can store, retrieve, and graphically present instrumentation data related to construction monitoring. A GIS is an effective and comprehensive means to monitor and analyze all aspects of a construction project, from its development as an idea to postconstruction operations and maintenance. Geotechnical information (data layers) can be a critical part of the data base management and analysis program. A GIS is an organized collection of computer hardware and software, geographic data, and personnel designed to efficiently collect, store, update, manipulate, analyze, and display geographically referenced information.

(c) Figure 2-8 is a flow diagram of the general procedure for carrying out construction investigations and documenting the results. A GIS is specifically designed to compile and analyze spatial data as depicted in Figure 2-8.

(3) Construction foundation and embankment criteria reports.

(a) The purpose of the foundation report is to ensure the preservation for future use of complete records of foundation conditions encountered during construction and methods used to adapt structures to these conditions. The foundation report is an important document for use in evaluating construction claims, planning additional foundation treatment should the need arise, evaluating the cause of foundation or structural feature distress and planning remedial action to prevent failure or partial failure of a structure, planning and design of major rehabilitation or modifications to the structure, providing

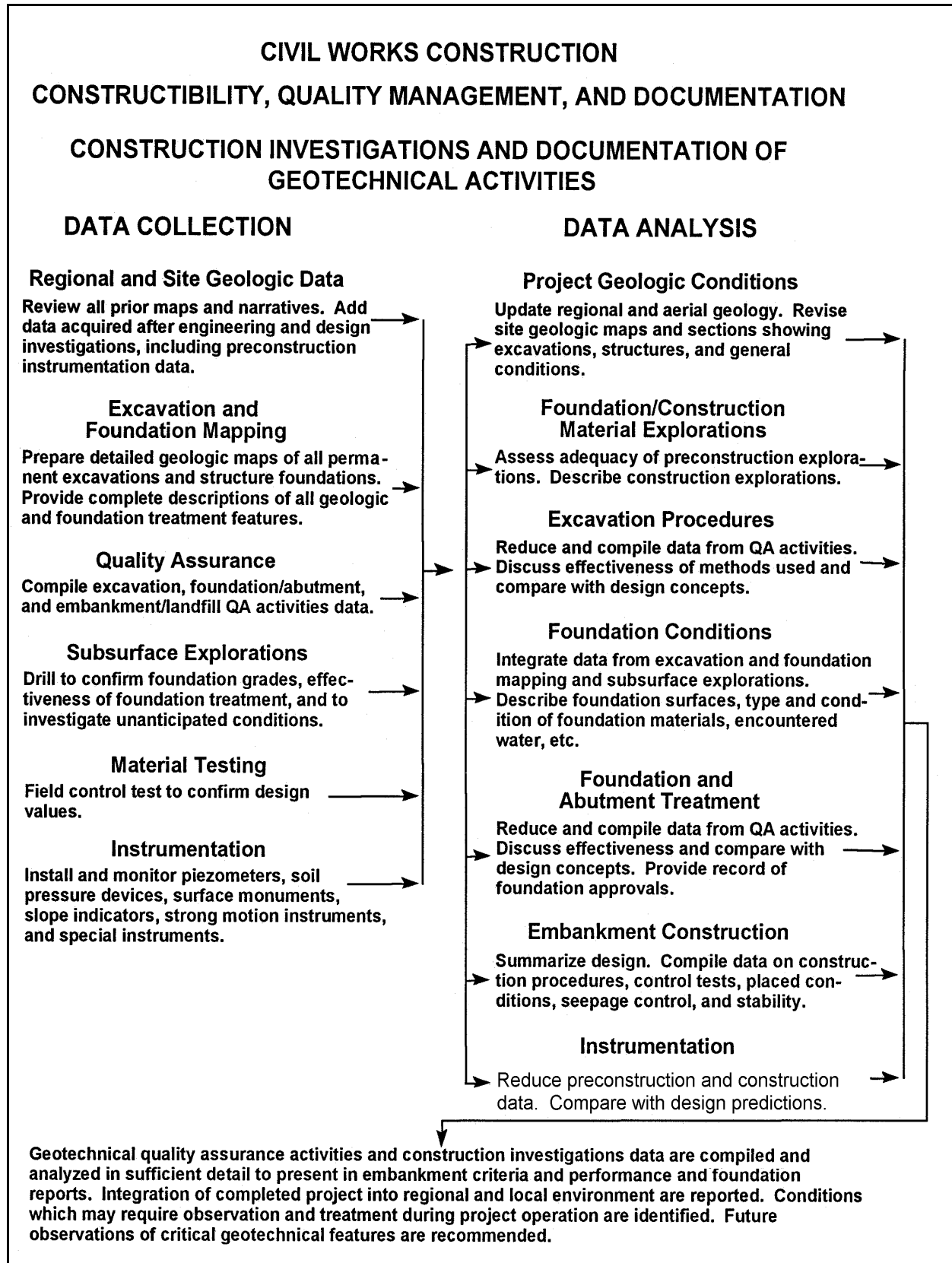

Figure 2-8. Schematic diagram of construction geotechnical investigations and documentation

guidance in planning foundation explorations, and in anticipating foundation problems for future comparable construction projects in similar geologic settings. Site geotechnical personnel responsible for the foundation report must begin to formulate the report as soon as possible after construction begins so that completion of the report can be accomplished by those who participated in the construction effort. This report should include collaboration with design and construction personnel. Detailed video recordings of foundation conditions should be an integral component of the foundation report.

(b) For major embankments, an embankment and performance criteria report will be prepared to provide a summary record of significant design data, design assumptions, design computations, specification requirements, construction equipment and procedures, construction experience, field and record control test data, and embankment performance as monitored by instrumentation during construction and during initial reservoir fillings. The report will provide essential information needed by engineers to familiarize themselves with the project, reevaluate the embankment in the event of unsatisfactory performance, and provide guidance for designing comparable future projects. The report should be authored by persons with firsthand knowledge of the project design and construction. The report should be in preparation during construction and completed as soon as possible following project completion.

Section II
Military Construction Projects

2-5. Background

Program development for Military Construction Army (MCA), Air Force, and other Army projects from initial conception by the installation to final public law appropriation by Congress and construction accomplishment will require a general sequence of geotechnical investigations as shown on Table 2-1. For design phase investigation of facilities required to resist nuclear weapons effects, the guidance in this manual should be supplemented with appropriate material from TM 5-858-3. Information systems to support military construction activities are discussed in ER 1110-3-110.

Table 2-1
Sequence of Geotechnical Investigations with Project Development Stages

Project Development Stages		
Military Construction	Civil Works	Geotechnical Investigations
Preconstruction and site selection studies	Reconnaissance and feasibility study	Thorough literature search Development of regional geology Field reconnaissances and initial field investigations
Final design studies	Preconstruction planning and engineering General Design Memorandum and Feature Design Memoranda	Review of regional geology Site selection investigations Foundation and design investigations
Construction	Construction	Constructibility review, quality assurance, and postconstruction documentation activities

2-6. Preconcept and Site Selection Studies

a. Purpose and scope. Preconcept information compilation occurs during the guidance year of the MCA program development flow. During the year, the Major Area Commands (MACOM) will prepare annual programs, set priorities, and submit their programs. Initial action consists of preparation of Project Development Brochures (PDB). PDBs contain data necessary to plan, budget, and initiate design of construction projects. The initial PDB is general in nature and provides information regarding project and site conditions. The initial DD Form 1391 contains the preliminary information about the project. A preliminary site survey and subsurface evaluation is included. The preliminary site survey should include a background check to assess the potential for encountering HTRW on potential sites. After approval by the Department of the Army, the second PDB is formulated, generally by the District. This PDB contains total user requirements and complete site and utility support information. Information on general subsurface conditions and any special foundation requirements such as deep foundations or special treatment is included. The preconcept and site selection studies culminate in preconcept control data based on the approved PDB, including a cost estimate and necessary reference data.

b. Scope of geotechnical investigations. Geotechnical investigations during preconcept studies should be performed to a level which assures adequate information. They should be performed by the District's geotechnical element and be sufficiently complete to permit selection of the most favorable site within the regional physical setting, determine the general type of structure best suited to the site conditions, assess the geotechnical aspects of environmental impact, and ascertain the costs of the project. The scope of the investigations should not be greater than that necessary to accomplish these aims. For projects on existing military installations, much of the information needed for preconcept studies is already available and the additional investigation requirements will be minimal. For projects in new areas where information is not readily available, the investigation requirements will be similar to those for Civil Works Feasibility studies. Emphasis, however, will be placed on site-specific parameters relating to size and special requirements for each project.

c. Reporting. Geotechnical investigation results will be reflected in the information and decisions presented in DD Form 1391 and in developed PDBs. Results of drilling and testing programs and special investigations should be compiled in summary reports.

2-7. Concept Studies

a. Purpose and scope. Concept studies provide drawings and data developed prior to initiation of final design, and constitute approximately 35 percent of total design. They serve to define the functional aspects of the facility and provide a firm basis on which the district engineer can substantiate project costs and initiate final design. Included are project site plans, materials and methods of construction, and representative cross sections of structure and foundation conditions. The concept design is accomplished during the design year stage of the program development plan and leads to development of budget data. Budget data reflect firm construction requirements and contain a current working estimate. Data are used in congressional budget hearings.

b. Scope of geotechnical investigations. Geotechnical investigations for concept studies should be performed by the district's geotechnical element and should provide information similar to that included for the preconcept studies but should advance the information to the level required for design and budget development.

c. Reporting. Reporting of the results of the geotechnical investigations is included in the design analysis developed to the 35-percent design study level. Emphasis should be placed on selection of foundation types and the influences of subsurface conditions.

2-8. Final Design Studies

a. Purpose and scope. Final design studies provide a complete set of working drawings for a project, accompanied by appropriate technical specifications, design analyses, and detailed cost estimates covering all architectural, site, and engineering details. These documents are used to obtain construction bids and to serve as construction contract documents.

b. Scope of geotechnical investigations. Geotechnical investigations for final design should be performed by the district's geotechnical element and should provide additional information to the preconcept and concept stage investigations for a final and complete design. All detailed considerations for economic designs, environmental influences, and construction processes should be finalized. The level of information should be similar to that for Civil Works General Design Memorandum studies.

c. Reporting. The results of the geotechnical investigations will be included in the final design analysis. Information should be similar to that collected for Civil Works General Design Memorandum studies, except additional emphasis will be placed on analysis for selection of foundation types and details of the foundation design.

2-9. Construction Activities

a. Scope of geotechnical investigations. In addition to quality control testing, geotechnical activities will be required during construction for special considerations or problems. Such activities will be necessary to confirm design assumptions, analyze changed conditions, determine special treatment requirements, analyze failures, and provide new materials sources.

b. Reporting. Investigation results will be provided in special summary reports and in construction foundation reports as required for major or unique projects.

Chapter 3 Regional Geologic and Site Reconnaissance Investigations

3-1. Background

Regional geologic and site reconnaissance investigations are made to develop the project regional geology and to scope early site investigations. The steps involved and the data needed to evaluate the regional geology of a site are provided in Figure 2-1. The initial phase of a geologic and site reconnaissance investigation is to collect existing geologic background data through coordination and cooperation from private, Federal, State, and local agencies. Geologic information collected should then be thoroughly reviewed and analyzed to determine its validity and identify deficiencies. Geologic data should also be analyzed to determine additional data requirements critical to long-term studies at specific sites, such as ground water and seismicity, that will require advance planning and early action. Upon completion of the initial phase, a geologic field reconnaissance should be conducted to examine important geologic features and potential problem areas identified during collection of background data. Field observations are used to supplement background data and identify the need to collect additional data.

a. Geologic model. Geologic background and field data that are determined to be valid should be used to construct a geologic model for each site. The model, which will require revisions as additional information is obtained, should indicate possible locations and types of geologic features that would control the selection of project features. Preliminary geologic, seismic, hydrologic, and economic studies should be used to indicate the most favorable sites before preliminary subsurface investigations are started. Proper coordination and timing of these studies, and incorporation into a GIS, can minimize costs and maximize confidence in the results.

b. Small projects. Many civil works projects are too small to afford a complete field reconnaissance study as outlined below. For smaller projects, emphasis should be placed on compilation and analysis of existing data, remote sensing imagery, and subsurface information derived from on-site drilling and construction excavations. A geologist or geotechnical engineer should be available to record critical geotechnical information that comes to light during investigations. An extensive photographic and video record taken by personnel with some background in geology or geotechnical engineering can serve as a reasonable proxy for onsite investigations.

Section I

Coordination and Information Collection

3-2. Interagency Coordination and Cooperation

Sources of background information available from other organizations can have a substantial influence on project economy, safety, and feasibility. During initial investigations, project geologists may be unfamiliar with both the regional and local geology. Limited funds must be allocated to many diverse areas of study (e.g., economics, real estate, environment, hydrology, and geology). For these reasons, contacts should be made with Federal, State, and local agencies to identify available sources of existing geologic information applicable to the project. A policy of formal coordination with the USGS has been established as outlined in the following text. In addition, informal coordination should be maintained with state geological surveys because critical geologic data and technical information are often available from these agencies. Other organizations listed below may also provide valuable information.

a. Coordination with USGS. The 27 October 1978 Memorandum of Understanding (MOU) with the USGS provided for exchange of information to assure that all geologic features are considered in project planning and design. The MOU outlines three main activities:

(1) The USGS provides the Corps of Engineers with existing information and results of research and investigations of regional and local geology, seismology, and hydrology relevant to site selection and design.

(2) The USGS advises the Corps of Engineers on geologic, seismologic, and hydrologic processes where knowledge is well developed and on specific features of site and regional problems.

(3) The Corps provides the USGS with geologic, seismologic, and hydrologic data developed from Corps studies.

The MOU requires that the USGS be notified in writing if planning studies are to be initiated at a new site or reinitiated at a dormant project. The notification should specify the location of interest and identify specific geologic, seismologic, and hydrologic considerations for which information is needed.

b. Other organizations. Contacts and visits to offices of the following organizations can produce valuable geotechnical information in the form of published maps and reports and unpublished data from current projects.

(1) Federal agencies.

(a) Department of Agriculture. - Forest Service - Natural Resource Conservation Service

(b) Department of Energy.

(c) Department of Interior. - Bureau of Indian Affairs - Bureau of Land Management

- Bureau of Reclamation - Fish and Wildlife Service - Geological Survey

- National Park Service - National Biological Service.

(d) Department of Transportation. - Federal Highway Administration regional and state division offices.

(e) Environmental Protection Agency regional offices.

(f) Nuclear Regulatory Commission.

(g) Tennessee Valley Authority.

(2) State agencies.

- (a) Geological Surveys, Departments of Natural Resources, and Departments of Environmental Management.
- (b) Highway departments.
- (3) Municipal engineering and water service offices.
- (4) State and private universities (geology and civil engineering departments).
- (5) Private mining, oil, gas, sand, and gravel companies.
- (6) Geotechnical engineering firms.
- (7) Environmental assessment firms.
- (8) Professional society publications.

3-3. Survey of Available Information

Information and data pertinent to the project can be obtained from a careful search through published and unpublished papers, reports, maps, records, and consultations with the USGS, state geologic and geotechnical agencies, and other Federal, state, and local agencies. This information must be evaluated to determine its validity for use throughout development of the project. Deficiencies and problems must be identified early so that studies for obtaining needed information can be planned to assure economy of time and money. Especially in the case of larger projects, data are most effectively compiled and analyzed in a GIS format. Table 3-1 summarizes the sources of topographic, geologic, and special maps and geologic reports. Most states regulate well installation and operation and maintain water well data bases that extend back many years. Wells may be municipal, industrial, domestic, or may have been drilled for exploration or production of natural gas. The information that is commonly available includes date of installation, screened interval, installer's name, depth, location, owner, and abandonment data. Lithologic logs may also be available and, in rare cases, production and water quality information.

Section II

Map Studies and Remote Sensing Methods

3-4. Map Studies

Various types of published maps, such as topographic, geologic, mineral resource, soils, and special miscellaneous maps, can be used to obtain geologic information and develop regional geology prior to field reconnaissance and exploration work. The types of available maps and their uses are described in Dodd, Fuller, and Clark (1989).

a. Project base map. Spatial components typically used to define a GIS referenced base map include: topographic maps, aerial photographs (digital orthophotos), monumentation/survey control maps, surface/subsurface geology maps, land use maps, bathymetry maps, and various forms of remotely sensed data. Project-specific planimetric maps, digital terrain models (DTMs), and digital elevation models (DEMs) are produced through photogrammetric methods and can be generated using a GIS. A DTM may be used to interpolate and plot a topographic contour map, generate two-dimensional (2-D) (contour) or three-dimensional (3-D) (perspective) views of the modeled surface, determine earthwork quantities, and produce cross sections along arbitrary alignments.

**Table 3-1
Sources of Geologic Information**

Agency	Type of Information	Description	Remarks
USGS	Topographic maps	U.S. 7.5-minute series 1:24,000 (supersedes 1:31,680). Puerto Rico 7.5-minute series 1:20,000 (supersedes 1:30,000) Virgin Island 1:24,000 series. U.S. 15-minute series 1:62,500 (1:63,360 for Alaska) U.S. 1:100,000-scale series (quadrangle, county, or regional format) U.S. 1:50,000-scale county map series U.S. 1:250,000-scale series Digital elevation models are available for entire U.S. at 1:250,000, and for certain areas at 1:100,000 and 1:24,000 scales. Digital line graphs are available for some areas at 1:24,000, 1:65,000, 1:100,000 for: - Hydrography - Transportation - Boundaries - Hypsography	Orthophotoquad monochrome and color infrared maps also produced in 7.5- and 15-min series. New index of maps for each state began in 1976. Status of current mapping from USGS regional offices and in monthly USGS bulletin, "New publications of the U.S. Geological Survey." Topographic and geological information from the USGS can be accessed through the ESIC (1 800 USAMAPS)
USGS	Geology maps and reports	1:24,000 (1:20,000 Puerto Rico), 1:62,500, 1:100,000, and 1:250,000 quadrangle series includes surficial bedrock and standard (surface and bedrock) maps with major landslide areas shown on later editions 1:500,000 and 1:2,500,000	New index of geologic maps for each state began in 1976. List of geologic maps and reports for each state published periodically
USGS	Miscellaneous maps and reports	Landslide susceptibility rating, swelling soils, engineering geology, water resources, and ground water	Miscellaneous Investigation Series and Miscellaneous Field Studies Series, maps and reports, not well cataloged; many included as open file reports
USGS	Special maps	1:7,500,000 and 1:1,000,000: Limestone Resources, Solution Mining Subsidence, Quaternary Dating Applications, Lithologic Map of U.S., Quaternary Geologic Map of Chicago, Illinois, and Minneapolis, Minnesota, areas	
USGS	Hydrologic maps	Hydrologic Investigations Atlases with a principal map scale of 1:24,000; includes water availability, flood areas, surface drainage precipitation and climate, geology, availability of ground and surface water, water quality and use, and streamflow characteristics	Some maps show ground water contours and location of wells
USGS	Earthquake hazard	Seismic maps of each state (began in 1978 with Maine); field studies of fault zones; relocation of epicenters in eastern U.S.; hazards in the Mississippi Valley area; analyses of strong motion data; state-of-the-art workshops	Operates National Strong-Motion Network and National Earthquake Information Service publishes monthly listing of epicenters (worldwide). Information is available through ESIC (1 800 USAMAPS)

Table 3-1 (Continued)

Agency	Type of Information	Description	Remarks
USGS	Mineral resources	Bedrock and surface geologic mapping; engineering geologic investigations; map of power generating plants of U.S. (location of build, under construction, planned, and type); 7.5-min quadrangle geologic maps and reports on surface effects of subsidence into underground mine openings of eastern Powder River Basin, Wyoming	
USGS	Bibliography	"Bibliography of North American Geology," (USGS 1973)	USGS Professional Paper
American Geological Institute	Bibliography	(American Geological Institute) print counterpart. "Bibliography and Index of Geology" to "Geo Ref" digital index (USGS 1973)	1977 to present, 12 monthly issues plus yearly cumulative index
National Oceanic and Atmospheric Administration (NOAA)	Earthquake hazards	National Geophysical Center in Colorado contains extensive earthquake hazard information (303-497-6419)	
National Aeronautics and Space Administration (NASA)	Remote sensing data	Landsat, skylab imagery	
NOAA	Remote sensing data		
Earth Observation Sattelite (EOSAT)	Remote sensing data		
US Fish and Wildlife Service (FWS)	Wetlands	The National Wetlands Inventory maps at 1:24,000 for most of the contiguous U.S.	Available as maps or mylar overlays
USGS	Flood-prone area maps	1:24,000 series maps outlining floodplain areas not included in Corps of Engineers reports or protected by levees	Stage 2 of 1966 89th Congress House Document 465
USAEWES	Earthquake hazard	"State-of-the-Art for Assessing Earthquake Hazards in the United States," Miscellaneous Paper S-73-1 (Krinitzsky 1995)	Series of 29 reports, 1973 to present
Natural Resources Conservation Service (NRCS)	Soil survey reports	1:15,840 or 1:20,000 maps of soil information on photomosaic background for each county. Recent reports include engineering test data for soils mapped, depth to water and bedrock, soil profiles grain-size distribution, engineering interpretation, and special features. Recent aerial photo coverage of many areas. Soils maps at 1:7,500,000 and 1:250,000, 1:31,680, and 1:12,000 scale are available in digital format for some areas.	Reports since 1957 contain engineering uses of soils mapped, parent materials, geologic origin, climate, physiographic setting, and profiles

Table 3-1 (Concluded)

Agency	Type of Information	Description	Remarks
State Geologic Agencies	Geologic maps and reports	State and county geologic maps; mineral resource maps; special maps such as for swelling soils; bulletins and monographs; well logs; water resources, ground water studies	List of maps and reports published annually, unpublished information by direct coordination with state geologist
Defense Mapping Agency (DMA)	Topographic maps	Standard scales of 1:12,500, 1:50,000, 1:250,000 and 1:1,000,000 foreign and worldwide coverage, including photomaps	Index of available maps from DMA
American Association of Petroleum Geologists	Geological highway map series	Scale approximately 1 in. equal 30 miles shows surface geology and includes generalized time and rock unit columns, physiographic map, tectonic map, geologic history summary, and sections	Published as 12 regional maps including Alaska and Hawaii
TVA	Topographic maps, geologic maps and reports	Standard 7.5-min TVA-USGS topographic maps, project pool maps, large-scale topographic maps of reservoirs, geologic maps, and reports in connection with construction projects	Coordinate with TVA for available specific information
U.S. Department of Interior, Bureau of Reclamation (USBR)	Geologic maps and reports	Maps and reports prepared during project planning and design studies	List of major current projects and project engineers can be obtained. Reports on completed projects by interlibrary loan or from USAEWES for many dams
Agricultural Stabilization and Conservation Services Aerial Photography Field Office (APFO)	Aerial photographs	The APFO offers aerial photographs across the U.S. Typically a series of photographs taken at different times, as available for a given site	Information is available at 801-975-3503
USGS Earth Resources Observation Systems (EROS) Center (EDC)	Aerial photographic coverage	The EDC houses the nation's largest collection of space and aircraft acquired imagery	Information is available at 605-594-6151 or 1 800 USAMAPS
Satellite Pour l'Observation de la Terre' (SPOT)	Remote sensing imagery	High-resolution multispectral imagery produced by France's SPOT satellite imager is available for purchase	Contact for SPOT images is at 800-275-7768

(1) Geotechnical parameters resulting from surface and subsurface explorations can be georeferenced to a DTM resulting in a spatial data base capable of producing geologic cross sections and 2- and 3-D strata surface generation. Georeferencing spatial data requires that the information be precisely located. Global Positioning System (GPS) techniques offer a rapid and reliable way to accomplish this (EM 1110-1-1003). Even with a GPS however, surveyed monuments and benchmarks must be identified and used as control points in the survey. Benchmark and brass cap information is available through the National Geodetic Survey of NOAA for the entire United States guidance and criteria for monumentation installation and documentation on Corps projects is outlined in EM 1110-1-1002.

(2) A GIS can be used to streamline and enhance regional or site-specific geotechnical investigations by: (a) Verifying which information is currently available and what new data must be obtained or generated to fulfill requirements for the desired level of study; (b) Sorting and combining layers of information to evaluate the commonality of critical parameters and compatibility of proposed alternatives/sites; and (c) Assigning quantitative values and relational aspects of data combinations and classifications, e.g., computing the probability of correctly assigning a given liquifaction potential for a proposed foundation construction method at a given site location. In this respect, a geotechnically augmented GIS database can be used to quantify reliability and uncertainty for specific design applications and assumptions. Burrough (1986), ESRI (1992), Intergraph (1993), and Kilgore, Krolak, and Mistichelli (1993) provide further discussions of GIS uses and capabilities.

b. Topographic maps. Topographic maps provide information on landforms, drainage patterns, slopes, locations of prominent springs and wet areas, quarries, man-made cuts (for field observation of geology), mines, roads, urban areas, and cultivated areas. Requirements for topographic mapping and related spatial data are outlined in EM 1110-1-1005. If older topographic maps are available, especially in mining regions, abandoned shafts, filled surface pits, and other features can be located by comparison with later maps. Many topographic maps are available in digital format for computer analysis and manipulation. Image files of an entire 7-1/2 min (1:24,000) topographic map, for example, can be purchased. Digital elevation maps (DEM) provide a regular grid of elevation points that allow the user to reproduce the topography in a variety of display formats.

(1) Optimum use of topographic maps involves the examination of large- and small-scale maps. Certain features, such as large geologic structures, may be apparent on small-scale maps only. Conversely, the interpretation of active geomorphic processes will require accurate, large-scale maps with a small-contour interval. As a general rule, the interpretation of topographic maps should proceed from small-scale (large-area) maps through intermediate-scale maps to large-scale (small-area) maps as the geologic investigation proceeds from the general to the specific.

(2) Certain engineering geology information can be inferred from topographic maps by proper interpretation of landforms and drainage patterns. Topography tends to reflect the geologic structure, composition of the underlying rocks, and the geomorphic processes acting on them. The specific type of geomorphic processes and the length of time they have been acting on the particular geologic structure and rock type will control the degree to which these geologic features are evident on the topographic maps. Geologic features are not equally apparent on all topographic maps, and considerable skill and effort are required to arrive at accurate geologic interpretations. Analysis of aerial photographs in combination with large-scale topographic maps is an effective means to interpret the geology and geomorphology of a site. Information of geotechnical significance that may be obtained or inferred from aerial photographs and topographic maps includes physiography, general soil and rock types, rock structure, and geomorphic history.

c. Geologic maps. Surficial and “bedrock” geologic maps can be used to develop formation descriptions, formation contacts, gross structure, fault locations, and approximate depths to rock (U.S. Department of Interior 1977; Dodd, Fuller, and Clarke 1989). Maps of 1:250,000 scale or smaller are suitable for the development of regional geology because they can be used with remote sensing imagery of similar scale to refine regional geology and soils studies. Large-scale geologic maps (1:24,000) are available for some areas (Dodd, Fuller, and Clarke 1989). State geologic surveys, local universities, and geotechnical and environmental firms may be able to provide detailed geologic maps of an area. Large-scale geologic maps provide information such as local faults, orientations of joints, detailed lithologic descriptions, and details on depth to rock.

d. Mineral resource maps. Mineral resource maps produced by the USGS and state geological services are important sources of geologic information. For example, the USGS coal resources evaluation program includes preparation of geologic maps (7.5-min quadrangle areas) to delineate the quantity, quality, and extent of coal on Federal lands. The USGS and state geologic service maps provide information on oil and gas lease areas and metallic mineral resource areas. Mineral resource maps also include information on natural construction materials such as quarries and sand and gravel deposits. These maps can be used in estimating the effects of proposed projects on mineral resources (such as access for future recovery, or reduction in project costs by recovery during construction).

e. Hydrologic and hydrogeologic maps. Maps showing hydrologic and hydrogeologic information provide a valuable source of data on surface drainage, well locations, ground water quality, ground water level contours, seepage patterns, and aquifer locations and characteristics. The USGS (Dodd, Fuller, and Clarke 1989), state geologic surveys, local universities, and geotechnical and environmental firms may provide this information.

f. Seismic maps. Krinitzsky, Gould, and Edinger (1993) show the distribution of seismic source areas for the United States and potential magnitude of earthquakes associated with each zone. Maps showing the timing and location of >4.5 magnitude earthquakes in the United States for the period 1857-1989 have been published by Stover and Coffman (1993).

(1) The Applied Technology Council (1978) published a seismic coefficient map for the United States for both velocity-based and acceleration-based coefficients. Seismic coefficients are dimensionless units that are the ratio between the acceleration associated with a particular frequency of ground motion and the response in a structure with the acceleration of the ground (Krinitzsky 1995). For the same ground motion frequency, seismic coefficients systematically vary for different types of structures (e.g., dams, embankments, buildings). These coefficients include a judgmental factor, representing experience on the part of structural engineers.

(2) Spectral Acceleration (%g) Maps for various periods of ground motion are being generated to assess seismic hazard potential. The Building Seismic Safety Council will publish updated seismic hazard potential maps in 1997 that will be in the form of spectral values for periods of 0.3 and 1.0 sec (E. L. Krinitzsky, personal communication 1996).

g. Engineering geology maps. An engineering geology map for the conterminous United States has been published by Radbruch-Hall, Edwards, and Batson (1987). Regional engineering geology maps are also available. More detailed maps may be available from state geologic surveys. Dearman (1991) describes the principles of engineering geologic mapping.

3-5. Remote Sensing Methods

Conventional aerial photographs and various types of imagery can be used effectively for large-scale regional interpretation of geologic structure, analyses of regional lineaments, drainage patterns, rock types, soil characteristics, erosion features, and availability of construction materials (Rasher and Weaver 1990, Gupta 1991). Geologic hazards, such as faults, fracture patterns, subsidence, and sink holes or slump topography, can also be recognized from air photo and imagery interpretation, especially from stereoscopic examinations of photo pairs. Technology for viewing stereoscopic projections on the PC is available. Detailed topographic maps can be generated from aerial photography that have sufficient surveyed ground control points. Remote sensing images that are in digital format can be processed to enhance geologic features (Gupta 1991). Although it is normally of limited value to site-specific studies, satellite imagery generated by Landsat, Sky Lab, the Space Shuttle, and the French Satellite Pour l'Observation de la Terre (SPOT) satellites are useful for regional studies. Remote sensing methods listed below can be used to identify and evaluate topographic, bathymetric, and subsurface features:

a. Topographic/surface methods.

- (1) Airborne photography (mounted on helicopter or conventional aircraft).
- (2) Airborne spectral scanner (mounted on helicopter or conventional aircraft).
- (3) Photogrammetry (for imagery processing or mapping of airborne/satellite spectral scanned data).
- (4) Satellite spectral scanner (e.g., Landsat).
- (5) Satellite synthetic aperture radar (SAR).
- (6) Side-looking airborne radar (SLAR).

b. Topographic/subsurface methods.

- (1) Ground Penetrating Radar (GPR).
- (2) Seismic.
- (3) Gravimeter.
- (4) Magnetometer.

c. Bathymetric methods.

- (1) Fathometer (vessel mounted).
- (2) Side-scan sonar (vessel mounted or towed).
- (3) Seismometer/subbottom profiler (bathymetry subsurface, vessel mounted, or towed).
- (4) Magnetometer (vessel towed).

- (5) Gravitometer (vessel towed).
- (6) Remotely Operated Vehicle (ROV) mounted video or acoustic sensor.
- (7) SeaBat (multibeam echo sounder) technology.

Gupta (1991) provides more detailed discussions of remote sensing techniques and their application to geotechnical investigations. Additional information concerning remote sensing surveying of bathymetry can be obtained in EM 1110-2-1003. Additional information concerning photographic imaging and photogrammetric mapping can be obtained in EM 1110-1-1000.

Section III
Field Reconnaissance and Observations

3-6. Field Reconnaissance

After a complete review of available geotechnical data, a geologic field reconnaissance should be made to gather information that can be obtained without subsurface explorations or detailed study (Dearman 1991). It is desirable that the geological field reconnaissance be conducted as part of a multidisciplinary effort. The composition of a team would depend upon the type and size of the project, the project effect on the area in question, and on any special problems identified as a result of early office studies. The team should include engineering geologists, soils engineers, planning engineers, archeologists, and representatives of other disciplines as appropriate. Duties include: field checking existing maps, cursory surface mapping (aided by aerial photographs), examining nearby natural and man-made outcrops, and traversing local waterways that expose rock and soil.

3-7. Observations

Observations made during field reconnaissances can be divided into five categories:

- a.* Examination of geologic/hydrologic features and geologic hazards to confirm, correct, or extend those identified during early office studies, and the preparation of regional geologic maps.
- b.* Assessment of site accessibility, ground conditions, and right-of-entry problems that could affect field exploration work.
- c.* Identification of cultural features that could affect exploration work and site location, especially utilities.
- d.* Evaluation of the condition of existing structures and construction practices that would indicate problem soil and rock conditions.
- e.* Identification of areas that could be contaminated by HTRW.

(1) Observations of geologic features should include rock outcrops and soil exposures to verify or refine available geologic maps. The strike and dip of major joint sets and evidence of joint sheeting or steeply dipping beds that would affect the stability of natural or excavated slopes should be noted. Indications of slope instability such as scarps, toe bulges, leaning trees, etc. should also be recorded. Table 3-2 outlines special geologic features and conditions which should be considered. The location of

sources of construction materials, such as large stone, sand and gravel deposits, clay soils, and active or abandoned quarries, are also important. Observable hydrologic features include surface drainage flow, springs and seeps in relation to formation members, and marshy or thick vegetation areas indicating high ground water tables.

(2) The location of cultural features, such as power lines, pipelines, access routes, and ground conditions that could restrict the location of or access to borings, should be noted. Historical and archaeological sites that may impact site location or construction practices should be identified and noted for further cultural resource potential studies. Local construction practices and the condition of existing structures and roads should be observed and potential problems noted. The location of abandoned mine workings such as adits, benches, shafts, and tailings piles should be noted.

(3) Field observations have special value in planning subsequent investigations and design studies because adverse subsurface conditions often can be anticipated from surface evidence and the regional geology. Suitable alternatives for foundation or structure types may be suggested by comprehensive field observations.

(4) Field reconnaissance can identify the need for new mapping and new aerial photographic coverage. Such coverage should be coordinated with planners early in the study process to ensure sufficient and timely coverage.

(5) Any potential environmental hazard such as former landfills, surface impoundments, mining activity, industrial sites, signs of underground storage tanks, or distressed vegetation should be recorded and assessed for HTRW potential.

Section IV
Information Development

3-8. Summary

Compiled and properly interpreted regional geologic data, coupled with information obtained during field reconnaissances, will provide the information necessary to identify suitable sites and to determine the scope of site investigations. Specifically, regional geology and site reconnaissance studies should result in the following:

- a. Regional geologic conditions identified and incorporated into a regional geologic map.
- b. Preliminary assessment made of regional seismicity.
- c. Tentative location of sources of construction materials.
- d. Tentative models of geologic conditions at suitable sites.
- e. Input for Environmental Impact Statement.
- f. Identification and assessment of potential for HTRW at prospective sites.

**Table 3-2
Special Geologic Features and Conditions Considered in Office Studies and Field Observations**

Geologic Feature or Condition	Influence on Project	Office Studies	Field Observations	Questions to Answer
Landslides	Stability of natural and excavated slopes	Determine presence or age in project area or at construction sites	Estimate areal extent (length and width) and height of slope	Are landslides found offsite in geologic formations of same type that will be affected by project construction?
		Compute shear strength at failure. Do failure strengths decrease with age of slopes-- especially for clays and clay shales?	Estimate ground slope before and after slide (may correspond to residual angle of friction)	What are probable previous and present ground water levels?
			Check highway and railway cuts and deep excavations, quarries, and steep slopes	Do trees slope in an unnatural direction?
Faults and faulting; past seismic activity	Of decisive importance in seismic evaluations; age of most recent fault movement may determine seismic design earthquake magnitude, may be indicative of high state of stress which could result in foundation heave or overstress in underground works	Determine existence of known faults and fault history from available information	Verify presence at site, if possible, from surface evidence; check potential fault traces located from aerial imagery	Are lineaments or possible fault traces apparent from regional aerial imagery?
		Examine existing boring logs for evidence of faulting from offset of strata	Make field check of structures, cellars, chimneys, roads, fences, pipelines, known faults, caves, inclination of trees, offset in fence lines	
Stress relief cracking and valley rebounding	Valley walls may have cracking parallel to valley. Valley floors may have horizontal cracking. In some clay shales, stress relief from valley erosion or glacial action may not be complete	Review pertinent geologic literature and reports for the valley area. Check existing piezometer data for abnormally low levels in valley sides and foundation; compare with normal ground water levels outside valley	Examine wells and piezometers in valleys to determine if levels are lower than normal ground water regime (indicates valley rebound not complete)	
Sinkholes; karst topography	Major effect on location of structures and feasibility of potential site (item 13)	Examine air photos for evidence of undrained depressions	Locate depressions in the field and measure size, depth, and slopes. Differences in elevation between center and edges may be almost negligible or many feet. From local residents, attempt to date appearance of sinkhole	Are potentially soluble rock formations present such as limestone, dolomite, or gypsum?
				Are undrained depressions present that cannot be explained by glaciation?
				Is surface topography rough and irregular without apparent cause?

Table 3-2 (Continued)

Geologic Feature or Condition	Influence on Project	Office Studies	Field Observations	Questions to Answer
Anhydrites or gypsum layers	Anhydrites in foundations beneath major structures may hydrate and cause expansion, upward thrust and buckling Gypsum may cause settlement, subsidence, collapse or piping. Solution during life of structure may be damaging	Determine possible existence from available geologic information and delineate possible outcrop locations	Look for surface evidence of uplift; seek local information on existing structures Check area carefully for caves or other evidence of solution features	Are uplifts caused by possible hydrite expansion or "explosion"?
Caves	Extent may affect project feasibility or cost. Can provide evidence regarding faulting that may relate to seismic design. Can result from unrecorded mining activity in the area		Observe cave walls carefully for evidence of faults and of geologically recent faulting. Estimate age of any broken stalactites or stalagmites from column rings	Are any stalactites or stalagmites broken from apparent ground displacement or shaking?
Erosion resistance	Need for total or partial channel slope protection is determined	Locate contacts of potentially erosive strata along drainage channels	Note stability of channels and degree of erosion and stability of banks	Are channels stable or have they shifted frequently? Are banks stable or easily eroded? Is there extensive bank sliding?
Internal erosion	Stability of foundations and dam abutments affected. Gravelly sands or sands with deficiency of intermediate particle sizes may be unstable and develop piping when subject to seepage flow	Locate possible outcrop areas of sorted alluvial materials or terrace deposits	Examine seepage outcrop areas of slopes and riverbanks for piping	
Area subsidence	Area subsidence endangers long- term stability and performance of project	Locate areas of high ground water withdrawal, oil fields and subsurface solution mining of underground mining areas	Check project area for new wells or new mining activity	Are there any plans for new or increased recovery of subsurface water or mineral resources?
Collapsing soils	Need for removal of shallow foundation materials that would collapse upon wetting determined	Determine how deposits were formed during geologic time and any collapse problems in area	Examine surface deposits for voids along eroded channels, especially in steep valleys eroded in fine-grained sedimentary formations	Were materials deposited by mud flows?

(Sheet 2 of 4)

Table 3-2 (Continued)

Geologic Feature or Condition	Influence on Project	Office Studies	Field Observations	Questions to Answer
Locally lowered ground water	May cause minor to large local and area settlements and result in flooding near rivers or open water and differential settlement of structures	Determine if heavy pumping from wells has occurred in project area; contact city and state agencies and USGS	Obtain ground water levels in wells from owners and information on withdrawal rates and any planned increases. Observe condition of structures. Contact local water plant operators	
Abnormally low pore water pressures (lower than anticipated from ground water levels)	May indicate effective stresses are still increasing and may cause future slope instability in valley sites	Compare normal ground water levels with piezometric levels if data are available		Is the past reduction in vertical stresses a possible cause of low pore water pressure. Examples are deep glacial valleys and deep excavations like that for the Panama Canal, where pore pressures in clay shale were reduced by stress relief.
In situ shear strength from natural slopes	Provides early indication of stability of excavated slopes or abutment and natural slopes around reservoir area	Locate potential slide areas. Existing slope failures should be analyzed to determine minimum in situ shear strengths	Estimate slope angles and heights, especially at river bends where undercutting erosion occurs. Determine if flat slopes are associated with mature slide or slump topography or with erosion features	Are existing slopes consistently flat, indicating residual strengths have been developed?
Swelling soils and shales	Highly preconsolidated clays and clay shales may swell greatly in excavations or upon increase in moisture content	Determine potential problem and location of possible preconsolidated strata from available information	Examine roadways founded on geologic formations similar to those at site. Check condition of buildings and effects of rainfall and watering	Do seasonal ground water and rainfall or watering of shrubs or trees cause heave or settlement?
Varved clays	Pervious layers may cause more rapid settlement than anticipated. May appear to be unstable because of uncontrolled seepage through pervious layers between overconsolidated clay layers or may have weak clay layers. May be unstable in excavations unless well points are used to control ground water	Determine areas of possible varved clay deposits associated with prehistoric lakes. Determine settlement behavior of structures in the area	Check natural slopes and cuts for varved clays; check settlement behavior of structures	

Table 3-2 (Concluded)

Geologic Feature or Condition	Influence on Project	Office Studies	Field Observations	Questions to Answer
Dispersive clays	A major factor in selecting soils for embankment dams and levees	Check with Soil Conservation Service and other agencies regarding behavior of existing small dams	Look for peculiar erosional features such as vertical or horizontal cavities in slopes or unusual erosion in cut slopes. Perform "crumb" test	
Riverbank and other liquefaction areas	Major effect on riverbank stability and on foundation stability in seismic areas	Locate potential areas of loose fine-grained alluvial or terrace sand; most likely along riverbanks where loose sands are present and erosion is occurring	Check riverbanks for scallop-shaped failure with narrow neck (may be visible during low water). If present, determine shape, depth, average slope, and slope of adjacent sections. Liquefaction in wooded areas may leave trees inclined at erratic angles. Look for evidence of sand boils in seismic areas	
Filled areas	Relatively recent filled areas would cause large settlements. Such fill areas may be overgrown and not detected from surface or even subsurface evidence	Check old topo maps if available for depressions or gullies not shown on more recent topo maps	Obtain local history of site from area residents	
Local overconsolidation from previous site usage	Local areas of a site may have been overconsolidated from past heavy loadings of lumber or material storage piles			Obtain local history from residents of area

(Sheet 4 of 4)

If an information system or electronic data base management capability already exists, serious consideration should be given at the beginning of a project to incorporate the geotechnical information into the system. Newly obtained/generated data should be incorporated into the information system data base for future project use. Data describing the site conditions encountered during construction should also be incorporated into the geotechnical data base. By electronically recording geotechnical information through the life cycle of a project, reliable diagnostic and forensic analysis can be conducted. Moreover, a GIS provides a powerful management tool for the postconstruction (operation and maintenance) phase of the project.

Chapter 4 Surface Investigations

4-1. Description of Operation

This chapter describes field operations that do not involve significant disturbance of the ground at the time the investigation is conducted. This type of investigation typically occurs at a preliminary stage of projects and supplies generalized information. However, these investigations can involve mapping specific locations in great detail during construction. The end product is commonly a pictorial rendering of conditions at the site. The degree of accuracy and precision required in such a rendering varies with the application and purpose for which the information is to be used. Some leeway in the degree of accuracy is required because of the inherent difficulty in presenting a 3-D subject in two dimensions. With computer-aided design and drafting (CADD) systems and specialized engineering application software packages, it is possible to portray 3-D information of greater complexity more effectively.

This chapter and the next describe in detail elements necessary for completion of a successful field investigation program for large civil and military projects. Several elements are applicable for refinement of regional geology investigations discussed in Chapter 3. Many civil works projects are, however, too small to afford complete onsite field investigations as outlined in the next two chapters. For smaller projects, emphasis should be placed on compilation and analysis of existing data, remote sensing imagery, and surface and subsurface information derived from onsite drilling and construction excavations. The following discussion can serve as a guide to the types of critical geotechnical information needed to support design and construction decisions.

Section I *Geologic Field Mapping*

4-2. Areal Mapping

The purpose of areal mapping is to develop an accurate picture of the geologic framework of the project area. The area and the degree of detail to be mapped can vary widely depending on the type and size of the project and on the complexity of the regional geology. In general, the area to be mapped should include the project site(s) as well as the surrounding area that could influence or could be influenced by the project. The information available from other sources should have been identified and collected during preliminary investigations (Chapter 3). If this was not done, or if for any reason it appears that additional useful information may be available, this information should be obtained and evaluated before expensive field investigations are begun. Only if existing geologic studies of an area have been combined with current geologic mapping and appropriate remote sensing techniques can an areal mapping program be considered complete. Such analysis is best carried out in a GIS. Utilization of GPS is a low cost and efficient alternative for providing precise horizontal and vertical measures to establish ground control points for georeferencing remote sensing images and for locating monitoring wells and other geologic sampling stations. GPS procedures are described in EM 1110-2-1003. For initial surface mapping, hand-held electronic distance measuring instruments are commonly sufficiently accurate and are efficient.

a. Reservoir projects. Geologic and environmental features within the reservoir and adjacent areas that should be studied and mapped include the following:

- (1) Faults, joints, stratigraphy, and other significant geologic features.
- (2) Karst topography or other features that indicate high reservoir leakage potential.
- (3) Water well levels, springs, surface water, water-sensitive vegetation, or other evidence of the ground water regime.
- (4) Soluble or swelling rocks such as gypsum or anhydrite.
- (5) Potential landslide areas around the reservoir rim.
- (6) Valuable mineral resources.
- (7) Mine shafts, tunnels, and gas and oil wells.
- (8) Potential borrow and quarry areas and sources of construction materials.
- (9) Shoreline erosion potential.
- (10) Landfills, dumps, underground storage tanks, surface impoundments, and other potential environmental hazards.

b. Other projects. The geologic features listed above are applicable in part to navigation locks and dams, main-line levees, coastal and harbor protection projects, and large or complex military projects. However, the scope and detail of the area mapped depend on the type and size of the project. Environmental engineering aspects of site investigations are covered in EM 1110-2-1202, -1204, -1205, and -1206 and Keller (1992). Procedures to investigate sedimentation in river and reservoir sites are discussed in EM 1110-2-4000.

4-3. Site Mapping

Large-scale and detailed geologic maps should be prepared for specific sites of interest within the project area and should include proposed structure areas and borrow and quarry sites. Investigation of the geologic features of overburden and rock materials is essential in site mapping and subsequent explorations. Determination of the subsurface features should be derived from a coordinated, cooperative study by geotechnical engineers and geologists. The geologist should contribute information on origin, distribution, and manner of deposition of the overburden and rock. The geotechnical engineer or engineering geologist should determine the engineering properties of the site foundation and potential construction materials, potential problem materials or conditions, application of geologic conditions to design, and the adaptation of proposed structures to foundation conditions.

a. Structure sites. A good preliminary geologic map should be prepared prior to making any subsurface borings to provide an approximate picture of the geologic conditions and hazards at a site. Such a map permits borings to be strategically located. For each proposed boring, an estimate should be made of the subsurface conditions that will be encountered, such as depths to critical contacts and to the water table. This estimate is possible, at least in an approximate manner, if geologic mapping has been performed to determine the geologic structure, lithology, and stratigraphy. The process of progressively refining the model of the geologic structure and stratigraphy by comparison with boring information is the most efficient and cost-effective means to develop a complete understanding of the geologic site

conditions. A digital format, such as CADD, provides a cost- and time-effective way to refine the model as new information becomes available.

b. Borrow and quarry sites. Sources of materials for embankment construction, riprap protection, and aggregates for concrete or road construction can often be located and evaluated during the course of regional mapping. It is sometimes necessary to expand the field area to locate suitable types and quantities of construction materials. In these instances, remote sensing techniques including analysis of aerial photography may be useful. Alternate plans that would make use of materials nearer to the project but lower in quality should be tentatively formulated and evaluated. A complete borrow and quarry source map should include all soil types encountered and all rock types with adequate descriptions of surficial weathering, hardness, and joint spacings.

(1) Processed rock products are usually most economically acquired from commercial sources. Test results are often available on these sources through state or Federal offices. The procedures for approval of construction materials sources are outlined in EM 1110-2-2301.

(2) Evaluation of soil and/or rock sources should be based upon sampling and laboratory analysis. By making field estimates of the thicknesses of various deposits, a geologic map may be used to estimate quantities available. Geologic maps can also be used to make a preliminary layout of haul and access roads and to estimate haul distances. A GIS is ideally suited to evaluate the quality and quantity of available quarry material, cost of excavation, and optimal transport routes.

4-4. Construction Mapping

Construction maps record in detail geologic conditions encountered during construction. Traditionally, a foundation map is a geologic map with details on structural, lithologic, and hydrologic features. It can represent structure foundations, cut slopes, and geologic features in tunnels or large chambers. The map should be prepared for soil and rock areas and show any feature installed to improve, modify, or control geologic conditions. Some examples are rock reinforcing systems, permanent dewatering systems, and special treatment areas. The mapping of foundations is usually performed after the foundation has been cleaned just prior to the placement of concrete or backfill. The surface cleanup at this time is generally sufficient to permit the observation and recording of all geologic details in the foundation. An extensive photographic and videographic record should be made during foundation mapping.

a. The person in charge of foundation mapping should be familiar with design intent via careful examination of design memoranda and discussion with design personnel. The actual geology should be compared with the geologic model developed during the design phase to evaluate whether or not there are any significant differences and how these differences may affect structural integrity. The person in charge of foundation mapping should be involved in all decisions regarding foundation modifications or additional foundation treatment considered advisable based on conditions observed after preliminary cleanup. Design personnel should be consulted during excavation work whenever differences between the actual geology and the design phase geological model require clarification or change in foundation design. Mapping records should include details of all foundation modifications and treatment performed.

b. Geologic maps and sections of the project which relate to construction and postconstruction procedures, hazards, or problems should be prepared for the Construction Foundation Report. Also, an edited video recording of excavation procedures, final foundation surfaces, treatment, etc. should be an integral part of the final report. The various geological data layers and video information are best compiled, analyzed, and prepared for presentation in a GIS.

c. Appendix B provides detailed guidance on technical procedures for mapping foundations. Mapping of tunnels and other underground openings must be planned differently from foundation mapping. Design requirements for support of the openings may require installation of support before an adequate cleanup can be made for mapping purposes. Consequently, mapping should be performed as the heading or opening is advanced and during the installation of support features. This requires a well trained geologist, engineering geologist, or geological engineer at the excavation at all times. Specifications should be included in construction plans for periodic cleaning of exposure surfaces and to allow a reasonable length of time for mapping to be carried out. Technical procedures for mapping tunnels are outlined in Appendix C and can be modified for large chambers.

Section II
Surface Geophysical Explorations

4-5. Background

Geophysical exploration consists of making indirect measurements from the earth's surface or in boreholes to obtain subsurface information. Geologic information is obtained through analysis or interpretation of these measurements. Boreholes or other subsurface explorations are needed to calibrate geophysical measurements. Geophysical explorations are of greatest value when performed early in the field exploration program in combination with limited subsurface exploration. They are appropriate for a rapid location and correlation of geologic features such as stratigraphy, lithology, discontinuities, ground water, and the in situ measurement of elastic moduli and densities. The cost of geophysical explorations is generally low compared with the cost of core borings or test pits, and considerable savings may be realized by judicious use of these methods.

4-6. Methods

The six major geophysical exploration methods are seismic, electrical resistivity, sonic, magnetic, radar, and gravity. Of these, the seismic and electrical resistivity methods have found the most practical application to the engineering problems of the Corps of Engineers (Steeple and Miller 1990, Society of Exploration Geophysicists 1990). Potential applications of selected geophysical methods are summarized in Tables 4-1 and 4-2. EM 1110-1-1802, Society of Exploration Geophysicists (1990), and Annan (1992) provide detailed guidance on the use and interpretation of geophysical methods. Special applications of microgravimetric techniques for sites with faults, fracture zones, cavities, and other rock irregularities have been made (Butler 1980).

**Table 4-1
Applications of Selected Geophysical and Other Methods for Determination of Engineering Parameters¹**

Method	Basic Measurement	Application	Advantages	Limitations
Surface				
Refraction seismic	Travel time of compressional waves through subsurface layers	Velocity determination of compression wave through subsurface. Depths to contrasting interfaces and geologic correlation of horizontal layers	Rapid, accurate, and relatively economical technique. Interpretation theory generally straightforward and equipment readily available	Incapable of detecting material of lower velocity underlying higher velocity. Thin stratum sometimes not detectable. Interpretation is not unique
Reflection seismic	Travel time of compressional waves reflected from subsurface layers	Mapping of selected reflector horizons. Depth determinations, fault detection, discontinuities, and other anomalous features	Rapid, thorough coverage of given site area. Data displays highly effective	Even with recent advances in high-resolution, seismic technology applicable to civil works projects is limited in area of resolution
Rayleigh wave dispersion	Travel time and period of surface Rayleigh waves	Inference of shear wave velocity in near-surface materials	Rapid technique which uses conventional refraction seismographs	Requires long line (large site). Requires high-intensity seismic source rich in low-frequency energy. Interpretation complex
Vibratory (seismic)	Travel time or wavelength of surface Rayleigh waves	Inference of shear wave velocity in near-surface materials	Controlled vibratory source allows selection of frequency, hence wavelength and depth of penetration (up to 200 ft). Detects low-velocity zones underlying strata of higher velocity. Accepted method	Requires large vibratory source, specialized instrumentation, and interpretation
Reflection profiling (seismic-acoustic)	Travel times of compressional waves through water and subsurface materials and amplitude of reflected signal	Mapping of various lithologic horizons; detection of faults, buried stream channels, and salt domes, location of buried man-made objects; and depth determination of bedrock or other reflecting horizons	Surveys of large areas at minimal time and cost; continuity of recorded data allows direct correlation of lithologic and geologic changes; correlative drilling and coring can be kept to a minimum	Data resolution and penetration capability are frequency-dependent; sediment layer thickness and/or depth to reflection horizons must be considered approximate unless true velocities are known; some bottom conditions (e.g., organic sediments) prevent penetration; water depth should be at least 15 to 20 ft for proper system operation

¹ From EM 1110-1-1802.

Table 4-1 (Continued)

Method	Basic Measurement	Application	Advantages	Limitations
Surface (Continued)				
Electrical resistivity	Electrical resistance of a volume of material between probes	Complementary to refraction seismic. Quarry rock, ground water, sand and gravel prospecting. River bottom studies and cavity detection	Economical nondestructive technique. Can detect large bodies of "soft" materials	Lateral changes in calculated resistance often interpreted incorrectly as depth related; hence, for this and other reasons, depth determinations can be grossly in error. Should be used in conjunction with other methods, e.g., seismic
Acoustic (resonance)	Amplitude of acoustically coupled sound waves originating in an air-filled cavity	Traces (on ground surface) lateral extent of cavities	Rapid and reliable method. Interpretation relatively straightforward. Equipment readily available	Still in experimental stage - limits not fully established. Must have access to some cavity opening
Ground Penetrating Radar	Travel time and amplitude of a reflect signal microwave	Rapidly profiles layering conditions. Stratification, dip, water table, and presence of many types of anomalies can be determined	Very rapid method for shallow site investigations. Online digital data processing can yield "onsite" look. Variable density display highly effective	Transmitted signal rapidly attenuated by water. Severely limits depth of penetration. Multiple reflections can complicate data interpretation
Gravity	Variations in gravitational field	Detects anticlinal structures, buried ridges, salt domes, faults, and cavities	Reasonably accurate results can be obtained, provided extreme care is exercised in establishing gravitational references	Equipment very costly. Requires specialized personnel. Anything having mass can influence data (buildings, automobiles, etc). Data reduction and interpretation are complex. Topography and strata density influence data
Magnetic	Variations of earth's magnetic field	Determines presence and location of magnetic materials in the subsurface. Locates ore bodies	Minute quantities of magnetic materials are detectable	Only useful for locating magnetic materials. Interpretation highly specialized. Calibration on site extremely critical. Presence of any metallic objects influences data
Borehole				
Uphole/downhole (seismic)	Vertical travel time of compressional and/or shear waves	Velocity determination of vertical P- and/or S-waves. Identification of low-velocity zones	Rapid technique useful to define low-velocity strata. Interpretation straightforward	Care must be exercised to prevent undesirable influence of grouting or casing
(Sheet 2 of 5)				

**Table 4-1
(Continued)**

Method	Basic Measurement	Application	Advantages	Limitations
Borehole (Continued)				
Crosshole (seismic)	Horizontal travel time of compressional and/or shear waves	Velocity determination of horizontal P- and/or S-waves. Elastic characteristics of subsurface strata can be calculated	Generally accepted as producing reliable results. Detects low-velocity zones provided borehole spacing not excessive	Careful planning with regard to borehole spacing based upon geologic and other seismic data an absolute necessity. Snell's law of refraction must be applied to establish zoning. A borehole deviation survey must be run. Highly experienced personnel required. Repeatable source required
Borehole spontaneous potential	Natural earth potential	Correlates deposits, locates water resources, studies rock deformation, assesses permeability, and determines ground water salinity	Widely used, economical tool. Particularly useful in the identification of highly porous strata (sand, etc.)	Log must be run in a fluid filled, uncased boring. Not all influences on potentials are known
Single-point resistivity	Strata electrical resistance adjacent to a single electrode	In conjunction with spontaneous potential, correlates strata and locates porous materials	Widely used, economical tool. Log obtained simultaneous with spontaneous potential	Strata resistivity difficult to obtain. Log must be run in a fluid filled, uncased boring. Influenced by drill fluid
Long and short normal resistivity	Near-hole electrical resistance	Measures resistivity within a radius of 16 and 64 in.	Widely used, economical tool	Influenced by drill fluid invasion. Log must be run in a fluid filled, uncased boring
Lateral resistivity	Far-hole electrical resistance	Measures resistivity within a radius of 18.7 ft	Less drill fluid invasion influence	Log must be run in a fluid filled, uncased boring. Investigation radius limited in low-moisture strata
Induction resistivity	Far-hole electrical resistance	Measures resistivity in air- or oil-filled holes	Log can be run in a nonconductive casing	Large, heavy tool
Borehole imagery (acoustic)	Sonic image of borehole wall	Detects cavities, joints, fractures in borehole wall. Determine attitude (strike and dip) of structures	Useful in examining casing interior. Graphic display of images. Fluid clarity immaterial	Highly experienced operator required. Slow log to obtain. Probe awkward and delicate. Borehole must be less than a 6-in. diam

(Sheet 3 of 5)

Table 4-1 (Continued)

Method	Basic Measurement	Application	Advantages	Limitations
Borehole (Continued)				
Continuous sonic (3-D) velocity	Time of arrival of P- and S-waves in high-velocity materials	Determines velocity of P- and S-waves in near vicinity of borehole. Potentially useful for cavity and fracture detection. Modulus determinations. Sometimes S-wave velocities are inferred from P-wave velocity and concurrently run nuclear logs through empirical correlations	Widely used method. Rapid and relatively economical. Variable density display generally impressive. Discontinuities in strata detectable	Shear wave velocity definition questionable in unconsolidated materials and soft sedimentary rocks. Only P-wave velocities greater than 5,000 fps can be determined
Natural gamma radiation	Natural radioactivity	Lithology, correlation of strata, may be used to infer permeability. Locates clay strata and radioactive minerals	Widely used, technically simple to operate and interpret	Borehole effects, slow logging speed, cannot directly identify fluid, rock type, or porosity. Assumes clay minerals contain potassium 40 isotope
Gamma-gamma density	Electron density	Determines rock density of subsurface strata	Widely used. Can be applied to quantitative analyses of engineering properties. Can provide porosity	Borehole effects, calibration, source intensity, and chemical variation in strata affect measurement precision. Radioactive source hazard
Neutron porosity	Hydrogen content	Moisture content (above water table) Total porosity (below water table)	Continuous measurement of porosity. Useful in hydrology and engineering property determinations. Widely used	Borehole effects, calibration, source intensity, and bound water all affect measurement precision. Radioactive source hazard
Neutron activation	Neutron capture	Concentration of selected radioactive materials in strata	Detects elements such as U, Na, Mn. Used to determine oil-water contact (oil industry) and in prospecting for minerals (Al, Cu)	Source intensity, presence of two or more elements having similar radiation energy affect data
Borehole magnetic	Nuclear precession	Deposition, sequence, and age of strata	Distinguishes ages of lithologically identical strata	Earth field reversal intervals under study. Still subject of research
Mechanical caliper	Diameter of borehole	Measures borehole diameter	Useful in a wet or dry hole	Must be recalibrated for each run. Averages three diameters
Acoustic caliper	Sonic ranging	Measures borehole diameter	Large range. Useful with highly irregular shapes	Requires fluid filled hole and accurate positioning

Table 4-1 (Concluded)

Method	Basic Measurement	Application	Advantages	Limitations
Borehole (Continued)				
Temperature	Temperature	Measures temperature of fluids and borehole sidewalls. Detects zones of inflow or fluid loss	Rapid, economical, and generally accurate	None of importance
Fluid resistivity	Fluid electrical resistance	Water-quality determinations and auxiliary log for rock resistivity	Economical tool	Borehole fluid must be same as ground water
Tracers	Direction of fluid flow	Determines direction of fluid flow	Economical	Environmental considerations often preclude use of radioactive tracers
Flowmeter	Fluid velocity and quantity	Determines velocity of subsurface fluid flow and, in most cases, quantity of flow	--	--
Sidewall sampling	--	--	--	--
Fluid sampling	--	--	--	--
Borehole dipmeter	--	--	--	--
Borehole surveying	Azimuth and declination of borehole drift	Determines the amount and direction of borehole deviation from the vertical normal	A reasonably reliable technique. Method must be used during the conduct of crosshole surveys to determine distance between seismic source and receivers	Errors are cumulative, so care must be taken at each measurement point to achieve precise data
Downhole flow meter	Flow across the borehole	Determines the rate and direction of ground water flow	A reliable, cost-effective method to determine lateral foundation leakage under concrete structures	Assumes flow not influenced by emplacement of borehole

Note: Blanks indicate no data.

(Sheet 5 of 5)

Table 4-2
Numerical Rating of Geophysical Methods to Provide Specific Engineering Parameters¹ Engineering Application

Geophysical Method	Depth to Rock	P-Wave Velocity	S-Wave Velocity	Shear Modulus	Young's Modulus	Poisson's Ratio	Lithology	Material Boundaries Stratigraphy	Dip of Strata	Density	In Situ State of Stress	Temperature	Permeability	Percent Saturation	Ground water Table	Ground water Quality	Ground water Aquifers	Flow Rate and/or Direction	Borehole Diameter	Obstructions	Rippability	Fault Detection	Cavity Detection	Cavity Delineation	Location of Ore Bodies	Borehole Azimuth and Inclination	
<u>Surface</u>																											
Refraction (seismic)	4	4	4	4	4	4	1	3	4	2	1	0	0	2	2	0	2	0	0	2	4	3	2	2	3	0	
Reflection (seismic)	4	0	0	0	0	0	1	4	4	0	0	0	0	0	2	0	1	0	0	2	0	4	3	3	3	0	
Rayleigh wave dispersion	1	0	2	2	0	0	1	3	0	2	1	0	0	0	0	0	0	0	0	1	0	0	0	1	2	0	
Vibratory (seismic)	2	0	4	4	4	0	1	3	0	2	1	0	0	0	0	0	0	0	0	2	2	1	2	2	3	0	
Reflection profiling (seismic-acoustic)	4	0	0	0	0	0	1	4	4	0	0	0	0	0	0	0	0	0	0	3	0	4	3	3	4	0	
Electrical potential ²	0	0	0	0	0	0	0	1	0	0	0	0	1	1	2	3	3	3	0	0	0	3	3	3	4	0	
Electrical resistivity	3	0	0	0	0	0	1	3	2	0	0	0	2	1	4	0	4	2	0	3	2	0	4	4	4	0	
Acoustic (resonance) ²	0	0	0	0	0	0	0	0	0	0	0	0	0	0	0	0	0	3	0	0	0	0	0	4	0	0	
Radar ^{2,3}	3	0	0	0	0	0	1	3	2	0	0	0	2	3	3	0	0	2	0	3	0	3	3	3	3	0	
Electromagnetic ²	4	0	0	0	0	0	3	4	1	0	0	0	1	2	3	1	2	0	0	0	0	3	0	0	4	0	
Gravity	3	0	0	0	0	0	0	0	1	0	0	0	0	0	0	0	0	0	0	4	0	1	3	3	3	0	
Magnetic ^{2,3}	0	0	0	0	0	0	0	0	1	0	0	0	0	0	0	0	0	0	0	0	0	0	2	2	4	0	
<u>Borehole</u>																											
Uphole/downhole (seismic)	4	4	4	4	4	4	1	4	0	2	1	0	0	2	2	0	2	0	0	1	2	3	0	2	2	0	
Crosshole (seismic)	4	4	4	4	4	4	1	4	2	2	1	0	0	2	2	0	2	0	0	3	2	3	3	2	3	0	

(Continued)

¹ Numerical rating refers to applicability of method in terms of current use and future potential:

0 = Not considered applicable

1 = Limited

2 = Used or could be used, but not best approach

3 = Excellent potential but not fully developed

4 = Generally considered as excellent approach; state of art well developed

A = In conjunction with other electrical and nuclear logs

² Methods not included in EM 1110-1-1802.

³ Airborne or inhole survey capability not considered.

Table 4-2 (Concluded)

Geophysical Method	Depth to Rock	P-Wave Velocity	S-Wave Velocity	Shear Modulus	Young's Modulus	Poisson's Ratio	Lithology	Material Boundaries Stratigraphy	Dip of Strata	Density	In Situ State of Stress	Temperature	Permeability	Percent Saturation	Ground water Table	Ground water Quality	Ground water Aquifers	Flow Rate and/or Direction	Borehole Diameter	Obstructions	Rippability	Fault Detection	Cavity Detection	Cavity Delineation	Location of Ore Bodies	Borehole Azimuth and Inclination	
<u>Borehole (Continued)</u>																											
Crosshole acoustic ²	4	4	4	4	4	0	1	3	4	0	0	0	1	0	3	0	0	0	0	1	3	3	3	3	0	0	
Crosshole resistivity ²	3	0	0	0	0	0	1	3	1	0	0	0	1	0	3	0	3	0	0	1	0	2	3	3	0	0	
Borehole spontaneous potential	2	0	0	0	0	0	4	4	4	2	0	0	0	0	4	2	4	0	0	1	0	2	2	1	3	0	
Single-point resistivity	2	0	0	0	0	0	4	4	1	0	0	0	0	1	4	2	4	0	0	1	0	1	1	1	2	0	
Long and short normal resistivity	2	0	0	0	0	0	4	4	1	1	0	0	0	4	3	0	2	0	0	0	0	1	1	2	4	0	
Lateral resistivity	2	0	0	0	0	0	3	4	1	1	0	0	0	4	3	0	2	0	0	0	0	1	1	2	4	0	
Induction-resistivity ²	2	0	0	0	0	0	4	4	1	1	0	0	0	4	3	0	2	0	0	0	0	1	1	2	4	0	
Borehole imagery acoustic	4	0	0	0	0	0	2	3	1	0	1	0	2	0	2	0	0	0	0	1	0	2	2	3	0	0	
Interval (3-D) velocity	2	4	2	2	2	2	2	3	1	2	1	0	0	1	1	0	0	0	0	1	0	3	2	2	2	0	
Natural gamma radiation	2	0	0	0	0	0	4	4	1	2	0	0	3A	1A	3A	2	2A	1	0	0	0	3A	1	1	4	0	
Gamma-gamma density	3A	0	0	0	0	0	4	4	1	3A	0	0	2A	3A	2A	0	0	0	0	0	3	3A	2	1	4	0	
Neutron porosity	2A	0	0	0	0	0	4	4	1	3A	0	0	2	3A	3A	0	0	0	0	0	0	3A	2	1	4	0	
Neutron activation ²	2A	0	0	0	0	0	3	1	1	0	0	0	2A	2	3A	0	0	2	0	1	0	1	0	0	4	0	
Borehole gravity ²	1	0	0	0	0	0	0	0	0	2	0	0	0	0	0	0	0	0	0	0	0	0	2	4	0	0	
Mechanical caliper	0	0	0	0	0	0	1	0	1	0	0	0	0	0	0	0	0	0	4	0	0	0	0	0	0	0	
Acoustic caliper	0	0	0	0	0	0	1	0	1	0	0	0	0	0	0	0	0	0	2	1	0	0	0	0	0	0	
Temperature	0	0	0	0	0	0	0	0	0	0	1	4	1	0	2	4	4	2	0	0	0	0	1	2	1	0	
Fluid resistivity	0	0	0	0	0	0	0	1	0	1	0	0	1	4	4	4	4	0	0	0	0	0	3	1	1	0	
Tracers ²	0	0	0	0	0	0	1	0	0	0	0	0	1	0	2	0	4	4	0	1	0	0	0	3	0	0	
Flowmeter ²	0	0	0	0	0	0	0	0	0	0	0	0	2	2	2	0	4	4	0	2	0	0	0	2	0	0	
Sidewall sampling ²	4	0	0	0	0	0	4	4	1	4	2	0	4	4	2	0	0	0	0	2	2	2	1	0	4	0	
Fluid sampling ²	0	0	0	0	0	0	0	0	0	0	0	4	1	0	4	4	4	2	0	0	0	0	0	0	0	0	
Borehole dipmeter ²	0	0	0	0	0	0	2	1	4	0	0	0	0	0	0	0	0	0	0	0	0	2	0	0	1	2	
Borehole surveying	0	0	0	0	0	0	0	0	0	0	0	0	0	0	0	0	0	0	0	0	0	0	0	0	0	4	

Chapter 5

Subsurface Investigations

5-1. Background

Subsurface investigations require use of equipment to gain information below the ground surface. The equipment is typically invasive and requires disturbance of the ground to varying degrees. Most of these exploration techniques are relatively expensive and therefore should be carefully planned and controlled to yield the maximum amount of information possible. It should be kept in mind that the quality of the information produced can vary significantly. If procedures are not followed carefully and data not interpreted properly, radically different conclusions can be reached. For example, poor drilling techniques could produce samples that might yield lower strength values. Therefore, only competent, senior geotechnical personnel should be charged with planning a subsurface investigation, and only qualified geotechnical professionals and technicians should do the drilling and data collecting, reducing, analyzing, and interpreting.

5-2. Location of Investigations

An important piece of information for all geotechnical investigations that seems obvious but commonly not given sufficient attention is the accurate determination of the location of investigation. It is always preferable to select boring and test pit locations that fully characterize geotechnical conditions. Although correlation of information from offsite may be technically defensible, because of variability of geologic materials, the legal defensibility of a piece of information is commonly lost if it is even slightly removed from the site. Of course, it is not always possible to locate a boring on a structure because of obstacles or right-of-entry difficulties. Heavily urbanized areas present particular difficulties in these aspects. However, it is important to keep in mind that correlations and interpretations may be subject to later scrutiny should a change of conditions claim be filed. All locations should be determined using either conventional surveying methods or by a GPS (EM 1110-1-1003). A GPS has the significant advantage of having the positional information downloaded directly into a GIS.

5-3. Protection of the Environment

a. After the locations for field investigations work have been determined, routes of access to the area and the specific sites for borings and excavations should be selected with care to minimize damage to the environment. Environmental engineering aspects of civil works projects are discussed in EM 1110-2-1202, -1204, -1205, and -1206 and Keller (1992). Operation of equipment will be controlled at all times and the extent of damaged areas will be held to the minimum consistent with the requirements for obtaining adequate data. Local laws pertaining to permissible levels of sediment flow from the site should be investigated. After the exploratory sites have served their purpose, the disturbed areas will be restored to a natural appearance. All borings and test pits should be backfilled in accordance with state environmental regulations.

b. Most states are now the primary regulatory agency for ground water quality assurance. As part of this responsibility many now require the certification of drillers. These regulations primarily apply to water well installation, but they may also apply to investigation programs. Ground water quality assurance has been the subject of considerable discussion from the standpoint of Federal Government responsibility for compliance with these regulations. Generally, Government drillers are not required to

have state certification but, in some instances, may be forced to comply for political reasons. This is not a clear-cut issue, and it should be resolved before beginning a drilling program.

c. The Federal Government has responsibility to ensure that environmental consciousness is maintained during the conduct of geotechnical investigations. Unfortunately, drilling rigs are inherently dirty. Proper maintenance of drilling rigs will minimize this problem. For HTRW exploratory drilling, drilling rigs must be steam cleaned and all tools, equipment, and personnel decontaminated in accordance with procedures established in the quality assurance and control (QAAC) plan. Fluids used in drilling operations, be they hydrocarbons that have leaked from the hydraulic system or a constituent of a drilling mud, are potentially toxic and should be controlled or eliminated wherever possible. EM 1110-1-4000 discusses requirements for maintenance and operation of drilling equipment at USACE HTRW sites. Aller et al. (1989) provide further guidance on acceptable design and installation of monitoring wells.

Section I
Borings

5-4. Major Uses

Borings are required to characterize the basic geologic materials at a project. The major uses for which borings are made are as follows:

- a.* Define geologic stratigraphy and structure.
- b.* Obtain samples for index testing.
- c.* Obtain ground water data.
- d.* Perform in situ tests.
- e.* Obtain samples to determine engineering properties.
- f.* Install instrumentation.
- g.* Establish foundation elevations for structures.
- h.* Determine the engineering characteristics of existing structures.

Borings are classified broadly as disturbed, undisturbed, and core. Borings are frequently used for more than one purpose, and it is not uncommon to use a boring for purposes not contemplated when it was made. Thus, it is important to have a complete log of every boring, even if there may not be an immediate use for some of the information. If there is doubt regarding the range of borehole use or insufficient information to determine optimum borehole size, then the hole should be drilled larger than currently thought needed. A slightly larger than needed borehole is considerably less expensive than a second borehole.

5-5. Boring and Sampling Methods

a. Common methods discussed. Many methods are used to make borings and retrieve samples. Some of the more common methods are discussed in the following paragraphs. Many of these are also

discussed in detail in Chapter 3, Appendix F; Das (1994); Hunt (1984); and Aller et al. (1989). Some factors that affect the choice of methods are:

- (1) Purpose and information required.
- (2) Equipment availability.
- (3) Depth of hole.
- (4) Experience and training of available personnel.
- (5) Types of materials anticipated.
- (6) Terrain and accessibility.
- (7) Cost.
- (8) Environmental impacts.
- (9) Disruption of existing structure.

b. Auger borings. Auger borings provide disturbed samples that are suitable for determining soil type, Atterberg limits, Proctor testing, and other index properties but generally give limited information on subsoil stratification, consistency, or sensitivity. Auger borings are most useful for preliminary investigations of soil type, advancing holes for other sampling methods, determining depth to top of rock, and for monitor well installation in soils. Auger borings can be made using hand, helical, barrel, hollow-stem, or bucket augers. Auger samples are difficult to obtain below the ground water table, except in clays. However, hollow-stem augers with a continuous split barrel sampler can retrieve some unconsolidated material from below the water table. Paragraph 3-4, Appendix F, describes the types of augers used in subsurface exploration. Paragraph 8-2, Appendix F, discusses sampling procedures when augering.

(1) Truck-mounted auger rigs currently come equipped with high yield and high tensile strength steel augers. New hydraulics technology can now apply torque pressures upward of 27,000 Nm (20,000 ft lb). With this amount of torque, augers are capable of boring large size holes and of being used in soft rock foundation investigations. Because augers use no drilling fluids, they are advantageous for avoiding environmental impacts. Appendix F, paragraph 3-3, describes auger drilling rigs. Another advantage of using augers is the ability (using hollow stems) for soil sampling, i.e., taking undisturbed samples below the bit.

(2) Currently, many drilling rigs are actually a combination of auger/core/downhole hammer units. A hollow-stem auger has the “drill through” capability (i.e., the auger can drill to refusal, then a wireline core barrel and drill rods can be inserted to finish the hole). The auger acts as a temporary casing to prevent caving of the softer materials as sampling progresses. However, the augers are not water tight and water loss should be anticipated. Hollow-stem augers should not be used as temporary casing in areas where HTRW is anticipated. Temporary steel casing driven into the surface of competent bedrock or PVC casing permanently grouted into the competent bedrock surface is required when HTRW is anticipated.

c. Drive borings. Drive borings provide disturbed samples that contain all soil constituents, generally retain natural stratification, and can supply data on penetration resistance. Drive boring is a nonrotating method for making a hole by continuous sampling using a heavy wall drive barrel. Push, or drive, samplers are of two types: open samplers and piston samplers. Open samplers have a vented sampler head attached to an open tube that admits soil as soon as the tube is brought in contact with the soil. Some open samplers are equipped with a cutting shoe and a sample retainer. Piston samplers have a movable piston located within the sampler tube. The piston helps to keep drilling fluid and soil cuttings out of the tube as the sampler advances. The piston also helps to retain the sample in the sampler tube. Where larger samples are required, the most suitable drill for this method is the cable tool rig. The cable tool rig has the capability to provide a downward driving force (drill stem on drive clamps) to make a hole and an upward force (drilling jars) to remove the drive barrel from the hole.

(1) Vibratory samplers offer a means of obtaining disturbed samples of saturated, cohesionless soils rapidly and with relatively inexpensive equipment (Appendix F). The simplest devices consist of a small gasoline engine providing hydraulic power to a vibrating head clamped to aluminum tubing secured on a tripod. The rapid vibrations within the head drives the sampling tube into the ground and forces the soil up into the tube. A rubber packer secured into the open end of the sampling tube after driving creates a seal to retain the sample as the tube is withdrawn with a hand winch.

(2) Another device, the Becker hammer drill, was devised specifically for use in sand, gravel, and boulders by Becker Drilling, LTD, Canada. The Becker drill uses a diesel-powered pile hammer to drive a special double-wall, toothed casing into the ground. Drilling fluid is pumped through an annulus to the bottom of the hole where it forces cuttings to the surface through the center of the casing. The cuttings are collected for examination. Becker drill casings are available in 14-cm (5.5-in.), 17-cm (6.6-in.), and 23-cm (9.0-in.) outside diameters (OD), with sampling inside diameters (ID) of 8.4 cm (3.3 in.), 10.9 cm (4.3 in.), and 15.2 cm (6.0 in.), respectively. Paragraph 5-23 and Appendix H describe Becker penetration test procedures. Appendix F, paragraph 3-3, discusses the Becker hammer drilling equipment and operation.

(3) The Standard Penetration Test (SPT) method of drive boring, described in ASTM D 1586-84 (ASTM 1996b), is probably the most commonly used method for advancing a hole by the drive method. Slight variations of this method, primarily concerning the sampling interval, cleanout method, and the refusal criteria exist from office to office but the fundamental procedure follows the ASTM standard. Appendix G presents procedures for SPT sampling and testing. Appendix G is compatible with the ASTM D 1586-84 standard and provides additional guidance in evaluating the test data. In this method, a standard configuration, 5-cm (2-in.) OD split barrel sampler at the end of a solid string of drill rods is advanced for a 0.45-m (1.5-ft) interval using a 623-Newton (N) (140-lb) hammer dropped through a 76-cm (30-in.) free fall. The blows required to advance the hole for each 15-cm (6-in.) interval are recorded on ENG Form 1836. The standard penetration resistance, or "N" value, is the sum of the blows required for the second and third 15-cm (6-in.) drives. The hole is then cleaned or reamed to the top of the next interval to be sampled and the procedure is repeated. Refusal is generally defined as 50 blows per 15 cm (per half foot) of penetration. When used to define the top of rock, great care and close examination of samples are required to minimize uncertainties. A few of the applications of SPT data are listed in paragraph 5-23a. This impact method may also be used with larger sample tubes and heavier hammers. Correlation studies to normalize data from larger holes to the SPT have been performed but are not completely reliable. The Becker hammer drill data can provide correlations of soil density and strength in coarse-grained soils similarly to the SPT test in finer-grained soils (paragraph 5-23a).

(4) Drive borings can be advanced quickly and economically with hollow-stem augers using a “plug” assembly that is either manually or mechanically set in the opening at the end of the auger string and then removed prior to sampling. Removal is commonly facilitated using a wire line system of retrieval. Where overburden prohibits the use of augers to advance the boring due to boulders or resistant rock lenses or ledges, other methods can be used. Traditionally, a roller rock bit using drilling mud will advance the hole at a modest cost in time and dollars. Where extremely difficult drilling conditions exist, an ODEX (eccentric reamer) down-the-hole air hammer system or other coring advancer apparatus can be used to penetrate the toughest boulders or ledges while still permitting the use of standard penetration or even undisturbed sampling to be conducted.

d. Cone penetration borings. The Cone Penetration Test (CPT) or Dutch cone boring is an in situ testing method for evaluating detailed soil stratigraphy as well as estimating geotechnical engineering properties (Schmertmann 1978a). The CPT involves hydraulically pushing a 3.6-cm (1.4-in.) diam special probe into the earth while performing two measurements, cone resistance and sleeve friction resistance. The probe is normally pushed from a special heavy duty truck but can also be performed from a trailer or drilling rig. Because of the weight of the truck or trailer needed to conduct CPT borings, access to soft ground sites is limited. Recent developments in CPT technology make it possible to retrieve physical soil samples and ground water or soil-gas samples with the same drive string used to perform the cone penetration test. CPT vehicles with push capacities up to 267 kiloNewtons (kN) (30 tons) have been developed. The Tri-Service Site Characterization and Analysis Penetrometer System (SCAPS), which is used to detect underground HTRW, is a technical variation of the CPT. The use of SCAPS reduces the time and cost of site characterization and restoration monitoring by providing rapid onsite real-time data acquisition/processing (i.e., in situ analysis) and onsite 3-D visualization of subsurface stratigraphy and regions of potential contamination. The Triservices operate several SCAPS vehicles including those of the U.S. Army Engineer District, (USAED) Kansas City, Savannah, and Tulsa, and the U.S. Army Engineer Waterways Experiment Station (USAEWES). Additional discussion of CPT is given in paragraph 5-23f.

e. Undisturbed borings. Appendix F, Chapters 5 and 6, discuss procedures for undisturbed sampling of soils. True “undisturbed” samples cannot be obtained because of the adverse effects resulting from sampling, shipping, or handling. However, modern samplers, used with great care, can obtain samples that are satisfactory for shear strength, consolidation, permeability, and density tests provided the possible effects of sample disturbance are considered. Undisturbed samples can be sliced to permit detailed study of subsoil stratification, joints, fissures, failure planes, and other details. Undisturbed samples of clays and silts can be obtained as well as nearly undisturbed samples of some sands.

(1) There are no standard or generally accepted methods for undisturbed sampling of noncohesive soils. One method that has been used is to obtain 7.6-cm (3-in.) Shelby (thin-wall) tube samples, drain them, and then freeze them prior to transporting them to the laboratory. Another method used consists of in situ freezing, followed by sampling with a rotary core barrel. Care is necessary in transporting any undisturbed sample, and special precautions must be taken if transporting sands and silts. For both methods, disturbance by cryogenic effects must be taken into account. Fixed-piston (Hvorslev) samplers, wherein a piston within a thin-walled tube is allowed to move up into the tube as the sampler is pushed into the soil, are adapted to sampling cohesionless and wet soils (Appendix F, paragraph 5-1a(2)).

(2) Undisturbed borings are normally made using one of two general methods: push samplers or rotary samplers. Push sampling types involve pushing a thin-walled tube using the hydraulic system of the drilling rig, then enlarging the diameter of the sampled interval by some “cleanout” method before beginning to sample again. Commonly used systems for push samples include the drill-rig drive,

whereby pressure is applied to a thin-walled (Shelby) sampling tube through the drill rods, the Hvorslev fixed-piston sampler, and the Osterberg hydraulic piston sampler. Rotary samplers involve a double tube arrangement similar to a rock coring operation except that the inner barrel shoe is adjustable but generally extends beyond the front of the rotating outer bit. This minimizes the disturbance to the sample from the drilling fluid and bit rotation. Commonly used rotational samplers include the Denison barrel and the Pitcher sampler. The Pitcher sampler has an inner barrel affixed to a spring-loaded inner sampler head that extends or retracts relative to the cutting bit with changes in soil stiffness. Drilling fluids are commonly used with rotary drilling equipment to transport cuttings to the surface and to increase the stability of the borehole. Chapter 4 of Appendix F discusses the types, preparation, and use of drilling fluids. The standard for thin-walled tube sampling of soils is ASTM D 1587-94 (ASTM 1996c), "Standard Practice for Thin-Walled Tube Sampling of Soils."

f. Rock core boring. Cored rock samples are retrieved by rotary drilling with hollow core barrels equipped with diamond- or carbide-embedded bits. The core is commonly retrieved in 1.5- to 3-m (5- to 10-ft) lengths. The "N" size hole (approximately 75 mm or 3 in.) is probably the core size most widely used by the Corps of Engineers for geotechnical investigations and produces a satisfactory sample for preliminary exploration work and, in many instances, for more advanced design studies. Other hole sizes, including B (approx 60 mm or 2.3 in.) and H (approximately 99 mm or 4 in.), are also quite satisfactory for geotechnical investigations. The decision on hole size should be based upon anticipated foundation conditions, laboratory testing requirements, and the engineering information desired. A double- or triple-tube core barrel is recommended because of its ability to recover soft or broken and fractured zones. The use of wireline drilling, whereby the core barrel is retrieved through the drill rod string, eliminates the need to remove the drill rods for sampling and saves a great deal of time in deep borings. Table 5-1 summarizes core and hole sizes commonly used in geotechnical studies. The rock boring is advanced without sampling using solid bits, including fishtail, or drag, bits, tri-cone and roller rock bits, or diamond plug bits.

(1) Most rock boring in the Corps of Engineers is accomplished using truck-mounted rotary drilling rigs. Skid-mounted rigs are also sometimes used in areas with poor access. Rotary drilling rigs are driven by the power takeoff from the truck engine or by independent engines. Boreholes are advanced by rotary action coupled with downward pressure applied to the drill bit and the cleaning action of the drilling fluid. Two types of pulldown mechanisms are normally used. Truck-mounted rotary drilling rigs equipped with a chain pulldown drive mechanism are capable of drilling to depths of 60 to 300 m (200 to 1,000 ft). Hydraulic feed drive rotary drilling rigs are capable of drilling to depths of 150 to 750 m (500 to 2,500 ft).

(2) Core recovery in zones of weak or intensely fractured rock is particularly important because these zones are typically the critical areas from the standpoint of foundation loading and stability. The use of larger-diameter core barrels in soft, weak, or fractured strata can improve core recovery and provides a statistically better size sample for laboratory testing. The advantages of larger cores must be weighed against their higher costs.

(3) Although the majority of rock core borings are drilled vertically, inclined, and horizontally oriented, borings may be required to adequately define stratification, jointing, and other discontinuities. A bias exists in the data favoring discontinuities lying nearly perpendicular to the boring. Discontinuities more nearly parallel to the boring are not intersected as often, and therefore, their frequency will appear to be much lower than it actually is. Inclined borings should be used to investigate steeply inclined jointing in abutments and valley sections for dams, along spillway and tunnel

**Table 5-1
Typical Diamond Core Drill Bit and Reaming Shell Dimensions**

Size	Bit Size		Reaming Shell
	OD, mm (in.)	ID, mm (in.)	OD and hole diam, mm (in.)
<u>"W" Group - "G" and "M" Design</u>			
EWG (EWX), EWM	37.3 (1.470)	21.5 (0.845)	37.7 (1.485)
AWG (AWX), AWM	47.6 (1.875)	30.1 (1.185)	48.0 (1.890)
BWG (BWV), BWM	59.6 (2.345)	42.0 (1.655)	59.9 (2.360)
NWG (NWX), NWM	75.3 (2.965)	54.7 (2.155)	75.7 (2.980)
HWG	98.8 (3.890)	76.2 (3.000)	99.2 (3.907)
<u>"W" Group - "T" Design</u>			
RWT	29.5 (1.160)	18.7 (0.735)	29.9 (1.175)
EWT	37.3 (1.470)	23.0 (0.905)	37.7 (1.485)
AWT	47.6 (1.875)	32.5 (1.281)	48.0 (1.890)
BWT	59.6 (2.345)	44.4 (1.750)	59.9 (2.360)
NWT	75.3 (2.965)	58.8 (2.313)	75.7 (2.980)
HWT	98.8 (3.890)	81.0 (3.187)	99.2 (3.907)
<u>Large-Diameter Design</u>			
2-3/4 X 3-7/8	97.5 (3.840)	68.3 (2.690)	98.4 (3.875)
4 X 5-1/2	138.1 (5.435)	100.8 (3.970)	139.6 (5.495)
6 X 7-3/4	194.4 (7.655)	151.6 (5.970)	196.8 (7.750)
<u>Wireline Sizes</u>			
AQ		27.0 ($1\frac{1}{16}$)	48.0 ($1\frac{57}{64}$)
BQ		36.5 ($1\frac{7}{16}$)	60.0 ($2\frac{23}{64}$)
NQ		47.6 ($1\frac{7}{8}$)	75.8 ($2\frac{63}{64}$)
HQ		63.5 ($2\frac{1}{2}$)	96.0 ($3\frac{25}{32}$)
PQ		85.0 ($3\frac{11}{32}$)	122.6 ($4\frac{53}{64}$)

alignment, and in foundations for other structures. In nearly vertical bedding, inclined borings can be used to reduce the total number of borings needed to obtain core samples of all strata.

(4) If precise geological structure is to be evaluated from core samples, techniques involving oriented cores are required. In these procedures, the core is scribed or engraved with a special drilling tool (Goodman 1976) so that its orientation is preserved. In this manner, both the dip and strike of any joint, bedding plane, or other planar surface can be ascertained. A more common procedure for obtaining dip and strike of structural features is the use of borehole photography or television. If the orientation of bedding is consistent across the site, it can be used to orient cores from borings which are angled to this bedding. Once oriented, the attitudes of discontinuities can be measured directly from the core.

(5) Large-diameter borings or calyx holes, 0.6 m (2 ft) or more in diameter, are occasionally used in large or critical structures. Their use permits direct examination of the sidewalls of the boring or shaft and provides access for obtaining high quality undisturbed samples. Direct inspection of the sidewalls may reveal details, such as thin, weak layers or shear planes that may not be detected by continuous undisturbed sampling. Large-diameter borings are produced with augers in soil and soft rock, and with large-diameter core barrels in hard rock.

5-6. Drilling in Embankments

The Corps of Engineers developed a special regulation concerning drilling operations in dam and levee embankments and their soil foundations (ER 1110-1-1807). In the past, compressed air and other drilling fluids have been used as circulating media to remove drill cuttings, stabilize bore holes, and cool and lubricate drilling bits. There have been several incidents of damage to embankments and foundations when drilling with air, foam, or water as the circulating medium. Damage has included pneumatic fracturing of the embankment while using air or air with foam, and erosion of embankment or foundation materials and hydraulic fracturing while using water. The new ER establishes a policy for drilling in earth embankments and foundations and replaces ER 1110-1-1807. The following points summarize the guidance provided in the new document:

a. Personnel involved in drilling in dam and levee embankments shall be senior and well qualified. Designs shall be prepared and approved by geotechnical engineers or engineering geologists. Drillers and “mud” specialists shall be experts in their fields.

b. Drilling in embankments or their foundations using compressed air or other gas or water as the circulating medium is prohibited.

c. Cable tool, auger, and rotary tool are recommended methods for drilling in embankments. One Corps District reports using a churn drill (a cable tool rig) to sample the clay core of a dam to a depth of 90 m (300 ft) with no damage to the core. If the cable tool method is used, drilling tools must be restricted to hollow sampling (drive) barrels in earth embankment and overburden materials. Appendix F, page 3-6, of this manual discusses the use of churn drills. If rotary drilling is used, an engineered drilling fluid (mud) designed to prevent caving and minimize intrusion of the drilling fluid into the embankment shall be used. An appendix in ER 1110-1-1807 provides detailed procedures for rotary drilling.

Section II

Drillhole Inspection and Logging

5-7. Objectives

A major part of field investigations is the compilation of accurate borehole logs on which subsequent geologic and geotechnical information and decisions are based. A field drilling log for each borehole can provide an accurate and comprehensive record of the lithology and stratigraphy of soils and rocks encountered in the borehole and other relevant information obtained during drilling, sampling, and in situ testing. To accomplish this objective, an experienced geologist, soils engineer, or civil engineer with good geotechnical training and experience should be present during drilling. The duties of the field inspector include the following:

- a. Making decisions on boring location, depth, and number and quality of samples required.
- b. Observing and describing drilling tools and procedures.
- c. Observing, classifying, and describing geologic materials and their discontinuities.
- d. Selecting and preserving samples.

- e. Performing field tests on soils (hand penetrometer, torvane).
- f. Photographing site conditions and rock cores.
- g. Observing and recording drilling activities and ground water measurements.
- h. Overseeing and recording instrument installation activities.
- i. Completing the drilling log, ENG FORM 1836 and/or entering information in BLDM (Nash 1993).
- j. Recording information and data from in situ tests.

The logs of borings are normally made available to contractors for use in preparing their bids. The descriptions contained on the logs of borings give the contractor an indication of the type of materials to be encountered and their in situ condition. Special care must be taken to ensure a clear differentiation in logs between field observations and laboratory test results. Guidance on soil identification and description, coring, and core logging is provided in the remainder of this section.

5-8. Soil Identification and Description

A thorough and accurate description of soils is important in establishing general engineering properties for design and anticipated behavior during construction. The description must identify the type of soil (clay, sand, etc.), place it within established groupings, and include a general description of the condition of the material (soft, firm, loose, dense, dry, moist, etc.). Characterization of the soils within a site provides guidance for further subsurface exploration, selection of samples for detailed testing, and development of generalized subsurface profiles (Das 1994). Initial field soil classification with subsequent lab tests and other boring data are recorded on the logs of borings. Soils should be described in accordance with ASTM D 2488-93 (ASTM 1996d). For civil works, the most widely used classification is the Unified Soil Classification System (USCS). The USCS outlines field procedures for determining plasticity, dilatancy, dry strength, particle size, and other engineering parameters. The USCS is described by Schroeder (1984) and in Technical Memorandum 3-357 (USAEWES 1982). A number of references provide detailed procedures to evaluate the physical properties of soils, including Cernica (1993), Lambe and Whitman (1969), Terzaghi, Peck, and Mesri (1996), and Means and Parcher (1963). In some cases, a standardized description of color using Munsell charts is useful. Some of the procedures, such as determining dry strength, may be impractical under certain field conditions and may be omitted where necessary. However, the checklists included in the procedure, if followed conscientiously, provide for a thorough description of soils. Examples for presenting soils data on ENG FORM 1836 are shown in Appendix D. Examples of well logs in the Boring Log Data Manager format are also presented in Appendix D.

5-9. Coring

Core drilling, if carefully executed and properly reported, can produce invaluable subsurface information. Basic procedures that should be followed and the information obtained can form the basis for comparison for widely diverse sites and conditions. The following subparagraphs outline procedures to report observations made during coring operations.

a. Drilling observations. During the coring operation, a great deal of information is available about the subsurface conditions that may or may not be apparent in the core recovered from the hole. Observation of the drilling action must be made and reported to present as complete a picture as possible of the subsurface conditions.

(1) If coring with water as a circulating medium, the inspector should note the amount of water return relative to the amount being injected through the drill rods and its color. Careful observation of drill water return changes can indicate potential intervals where pressure test takes can be anticipated and correlated. Changes in the color of the return water can indicate stratigraphic changes and degrees of weathering such as clay-filled joints and cavity fillings.

(2) If available, hydraulic pressure being exerted by the drill should be recorded on each run as well as the fluid water pressure. While the drill is turning, the inspector should correlate drilling depths to drilling action (e.g., smooth or rough), increases and decreases applied by the drill operator to the feed control valve, and the rate of penetration. Rod drop depths, which indicate open zones, should be recorded. Changes in drilling rates can be related to changes in composition and/or rock structure and, in areas of poor core recovery, may provide the only indication of the subsurface conditions.

b. Procedural information. Regardless of the program undertaken, all logs should at least include the following: size and type of core bit and barrel used; bit changes; size, type, and depth of casing; casing shoe and/or casing bit used; problems or observations made during placement of the casing; change in depth of casing setting during drilling; depth, length, and time for each run; length/depth of pull (the actual interval of core recovered in the core run); amount of core actually recovered; amount of core loss or gain; and amount of core left in the hole (tape check). The inspector should note the presence of a flange on the bottom of a core string because a flange indicates that the core was retrieved from the bottom of the drilled hole. From these data the unaccountable loss, i.e., the core that is missing and unaccounted for, should be computed. Core loss should be shown on the graphic log and by blocks or spacers in the core box at its most likely depth of occurrence based upon the drilling action and close examination of the core. The boring should be cleaned and the total depth taped to determine the amount of cored rock left in the hole on the final run.

5-10. Core Logging

Each feature logged shall be described in such a way that other persons looking at the core log will recognize what the feature is, the depth at which it occurred in the boring, and its thickness or size. They should also be able to obtain some idea of the appearance of the core and an indication of its physical characteristics. The log shall contain all the information obtainable from the core pertaining to the rock as well as discontinuities. Examples for presenting core logging data on ENG FORM 1836 are shown in Appendix D.

a. Rock description. Each lithologic unit in the core shall be logged. The classification and description of each unit shall be as complete as possible. A recommended order of descriptions is as follows:

- (1) Unit designation (Miami oolite, Clayton formation, Chattanooga shale).
- (2) Rock type and lithology.
- (3) Hardness, relative strength, or induration..

- (4) Degree of weathering.
- (5) Texture.
- (6) Structure.
- (7) Discontinuities (faults, fractures, joints, seams).
 - (a) Orientation with respect to core axis.
 - (b) Asperity (surface roughness).
 - (c) Nature of infilling or coating, if present.
 - (d) Staining, if present.
 - (e) Tightness.
- (8) Color.
- (9) Solution and void conditions.
- (10) Swelling and slaking properties, if apparent.
- (11) Additional descriptions such as mineralization, inclusions, and fossils.

Criteria for these descriptive elements are contained in Table B-2 (Appendix B). Murphy (1985) provides guidelines for geotechnical descriptions of rock and rock masses. Geological Society Engineering Group Working Party Report (1995) suggests a description and classification scheme of weathered rocks for engineering purposes. Variation from the general description of the unit and features not included in the general description should be indicated at the depth and the interval in the core where the feature exists. These variations and features shall be identified by terms that will adequately describe the feature or variation so as to delineate it from the general description. Features include zones or seams of different color and texture; staining; shale seams, gypsum seams, chert nodules, and calcite masses; mineralized zones; vuggy zones; joints; fractures; open and/or stained bedding planes, roughness, planarity; faults, shear zones, and gouge; cavities, thickness, open or filled, and nature of filling; and core left in the bottom of the hole after the final pull.

b. Rock quality designation. A simple and widely used measure of the quality of the rock mass is provided by the Rock Quality Designation (RQD), which incorporates only sound, intact pieces 10 cm (4 in.) or longer in determining core recovery. In practice, the RQD is measured for each core run and reported on ENG Form 1836. Many of the rock mass classification systems in use today are based, in part, on the RQD. Its wide use and ease of measurement make it an important piece of information to be gathered on all core holes. It is also desirable because it is a quantitative measure of core quality at the time of drilling before handling and slaking have had major effect. Deere and Deere (1989) reevaluated the use of RQD from experience gained in the 20 years since its inception. They recommended modifications to the original procedure after evaluating results of field use. Figure 5-1 illustrates the modified procedure of Deere and Deere.

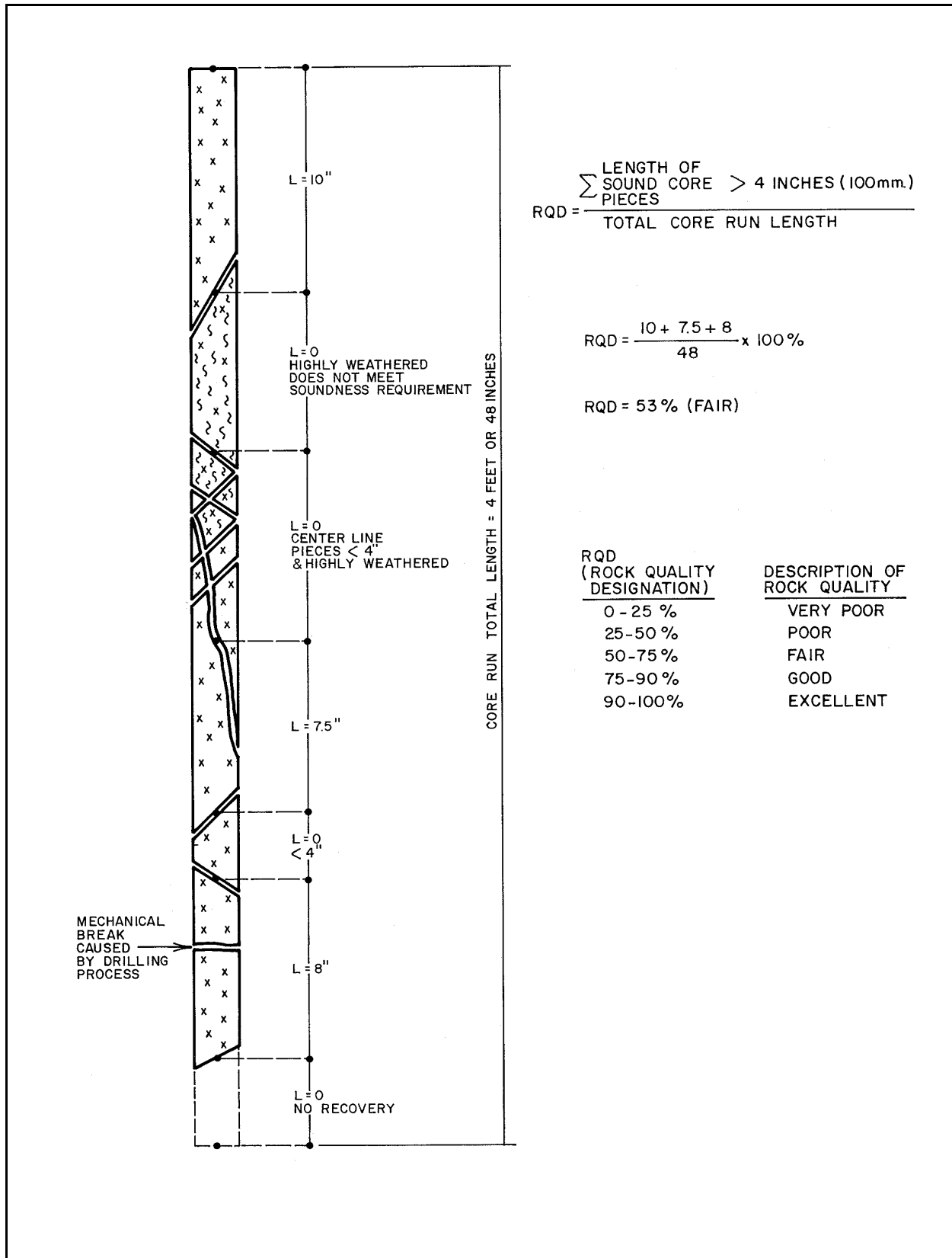

Figure 5-1. Illustration of Deere and Deere (1989) modified procedure for calculating RQD

(1) RQD was originally recommended for NX size (5.474-cm- or 2.155-in.-diam) core, but Deere and Deere expanded its use to the somewhat smaller NQ wireline sizes (4.763 cm or 1-7/8 in.) and to larger wireline sizes up to 8.493 cm (3-11/32 in.) and other core sizes up to 15 cm (6 in.). They discouraged RQD use with the smaller BQ (3.651-cm or 1-7/16-in.) and BX (4.204-cm or 1.655-in.) cores because of core breakage.

(2) Core segment lengths should be measured along the centerline or axis of the core, as illustrated in Figure 5-1.

(3) The inspector should disregard mechanical breaks (breaks caused by drilling action or handling) when calculating RQD.

(4) RQD should be performed at the time the core is retrieved to avoid the effects of postremoval slaking and separation of core along bedding planes, as in some shales.

(5) Emphasis should be placed on core being “sound.” Pieces of core that do not meet the subjective “soundness” test should not be counted. Indicators of “unsound” rock are discolored or bleached grains or crystals, heavy staining, pitting, or weak grain boundaries. Unsound rock is analogous to “highly weathered” rock, which is characterized by weathering extending throughout the rock mass.

Several papers have appeared since Deere and Deere (1989) suggesting alternatives or modified applications of RQD to systems of discontinuities that are perhaps less amenable to analysis by the original procedure. Boadu and Long (1994) established a relation between RQD and fractal dimension (the degree to which a system is self-similar at different scales). The relationships may have application in fracture geometries with complex distributions. Eissa and Sen (1991) suggest alternative analytical methods to RQD when dealing with fracture networks, that is, sets of fractures in more than one direction. Similar alternative approaches to systems of fractures in three dimensions (a volumetric approach) were proposed by Sen and Eissa (1991). Special attention should be paid to the nature of all discontinuities. These are most often what control the engineering behavior of the foundation rock mass and slope stability.

c. Solution and void conditions. Solution and void conditions shall be described in detail because these features can affect the strength of the rock and can indicate potential ground water seepage paths. Where cavities are detected by drilling action, the depth to top and bottom of the cavity should be determined by measuring. Filling material, where present and recovered, should be described in detail opposite the cavity location on the log. If no material is recovered from the cavity, the inspector should note the probable conditions of the cavity, as determined by observing the drilling action and the color of the drilling fluid. If drilling action indicates material is present, e.g., a slow rod drop, no loss of drill water, or noticeable change in color of water return, it should be noted on the log that the cavity was probably filled and the materials should be described as well as possible from the cuttings or traces left on the core. If drilling action indicates the cavity was open, i.e., no resistance to the drilling tools and/or loss of drilling fluid, it should be noted on the drilling log. By the same criteria, partially filled cavities should be noted. If possible, filling material should be sampled and preserved. During the field logging of the core at the drilling site, spacers should be placed in the proper position in core boxes to record voids and losses.

d. Photographic and video record. A color photographic record of all core samples should be made. Photographs should be taken as soon as possible after retrieving the core samples. The core photographs can be reproduced on 20- by 25-cm (8- by 10-in.) prints, two or three core boxes to a photograph, and the photographic sheets placed in a loose-leaf binder for convenient reference. Photographs often enhance the logged description of cores particularly where rock defects are abundant.

In the event that cores are lost or destroyed, the photographic record becomes the only direct, visual means for review of subsurface conditions without expensive re-drilling. A video recording of the drilling operation provides an excellent record of drilling equipment and procedures. Moreover, video may provide a record of critical events or conditions that were not obvious at the time, or occurred too quickly to be recorded manually.

5-11. Drilling Log Form and the Boring Log Data Management Program

All soil and rock drilling logs will be recorded using ENG FORM 1836 as the standard, official log of record. As a general rule, the depth scale on each sheet should normally be 3 m (10 ft) per page and no smaller than 6 m (20 ft). Examples of completed drilling logs are shown in Appendix D. A PC-based, menu-driven boring log data management program (BLDM) is available for free to COE personnel through CEWES-GS-S. The BLDM allows users to create and maintain boring log data, print reports, and create data files which can be exported to a GIS (Nash 1993). Examples of BLDM output are presented in Appendix D.

Section III *Borehole Examination and Testing*

5-12. Borehole Geophysical Testing

A wide array of downhole geophysical probes is available to measure various formation properties (Tables 4-1 and 4-2). Geophysical probes are not a substitute for core sampling and analysis, however, but they are an economical and valuable supplement to the core sample record. Some very sophisticated analyses of rock mass engineering properties are possible through the use of downhole geophysics. These services are available through commercial logging companies and various Government agencies. Recent developments in microcomputer technology have made it possible to apply procedures known as crosshole tomography to borehole seismic and resistivity data (Cottin et al. 1986; Larkin et al. 1990). Through computer analysis of crosshole seismic and resistivity data, tomography produces a 3-D rendition of the subsurface. The level of detail possible depends upon the distance between holes, the power of the source, and the properties of the rock or soil mass. The method can be used for both indurated and nonindurated geomaterials.

5-13. Borehole Viewing and Photography

The interpretation of subsurface conditions solely by observation, study, and testing of rock samples recovered from core borings often imposes an unnecessary limitation in obtaining the best possible picture of the site subsurface geology. The sidewalls of the borehole from which the core has been extracted offer a unique picture of the subsurface where all structural features of the rock formation are still in their original position. This view of the rock can be important, particularly if portions of rock core have been lost during the drilling operation and if the true dip and strike of the structural features are required. Borehole viewing and photography equipment includes borescopes, photographic cameras, TV cameras, sonic imagery loggers, caliper loggers, and alinement survey devices. Sonic imagery and caliper loggers are discussed in detail in EM 1110-1-1802. Alinement survey services are available from commercial logging or drilling firms and from the U.S. Army Engineer Waterways Experiment Station (CEWES-GG-F). Borehole viewing systems and services are often obtained now from private industry or from the few COE offices that have the capabilities.

5-14. Borehole Camera and Borescope

Borehole film cameras that have limited focus capability are satisfactory for examining rock features on the sidewalls of the borehole. However, the small viewing area and limited focus reduce the usefulness in borings that have caved or that have cavities. They are best used for examining soft zones for which core may not have been recovered in drilling, for determination of the dip and strike of important structural features of the rock formation, and to evaluate the intrusion of grout into the rock mass. The camera's film must be processed before the images can be examined. The borescope, basically a tubular periscope, has limited use because of its small viewing area, limited depth, and cumbersome operation. It is relatively inexpensive to use, however.

5-15. Borehole TV Camera and Sonic Imagery

The TV camera has variable focus and is suitable for examining the nature and approximate dimensions of caving sections of open boreholes or boreholes filled with clear water. The TV camera provides both real-time imagery and a permanent record of the viewing session. The sonic imagery (televviewer) system uses acoustic pulses to produce a borehole wall image and can be used in a hole filled with drilling mud. The TV camera is used to examine cavities in the rock such as solution voids in calcareous formations, open cooling joints, and lava tunnels in volcanic rocks, mines, tunnels, and shafts. Most TV systems are capable of both axial (downhole) and radial (sidewall) viewing. The televviewer can be used to distinguish fractures, soft seams, cavities, and other discontinuities. Changes in lithology and porosity may also be distinguished. Specially designed borehole television cameras and sonic imagers or televviewers can be used to determine the strike and dip of discontinuities in the borehole wall. The Corps of Engineers has this capability at the U.S. Army Engineer District, Walla Walla, WES, and the U.S. Army Engineer Division Laboratory, Southwestern.

5-16. Alinement Surveys

Alinement surveys are often necessary if the plumbness and/or orientation of a hole is important. Older methods employed a compass and photograph system which was relatively easy to use. More modern systems are electronic. Alinement surveys may be critical in deep holes where instrumentation packages are to be installed or where precise determinations of structural features in the rock formation are required.

Section IV *Exploratory Excavations*

5-17. Test Pits and Trenches

Test pits and trenches can be constructed quickly and economically by bulldozers, backhoes, pans, draglines, or ditching machines. Depths generally are less than 6 to 9 m (20 to 30 ft), and sides may require shoring if personnel must work in the excavations. Test pits, however, hand dug with pneumatic jackhammers and shored with steel cribbing, can be dug to depths exceeding 18 m (60 ft). Test pits and trenches generally are used only above the ground water level. Test pits that extend below the water table can be kept open with air or electric powered dewatering pumps. Exploratory trench excavations are often used in fault evaluation studies. An extension of a rock fault into much younger overburden materials exposed by trenching is usually considered proof of recent fault activity. Shallow test pits are commonly used for evaluating potential borrow areas, determining the geomorphic history, and assessing cultural resource potential.

5-18. Calyx Hole Method

Large-diameter calyx holes have been used successfully on some jobs to provide access for direct observation of critical features in the foundations. These holes are very expensive to drill (possibly \$2,300 per meter or \$700 per foot), so their use is very limited. However, where in situ observation of a very sensitive feature, such as a shear zone or solution feature in the abutment of an arch dam, cannot be achieved reasonably by any other means, the calyx hole may be the procedure of choice.

Section V

Ground Water and Foundation Seepage Studies

5-19. General Investigation

The scope of ground water studies is determined by the size and nature of the proposed project. Efforts can range from broad regional studies at a reservoir project to site-specific studies, such as pumping tests for relief well design, water supply at a recreational area, or pressure tests performed to evaluate the need for foundation grouting. Ground water studies include observations and measurements of flows from springs and of water levels in existing production wells, boreholes, selected observation wells, and piezometers. This information is used with site and regional geologic information to determine water table or piezometric surface elevations and profiles, fluctuations in water table elevations, the possible existence and location of perched water tables, depths to water-bearing horizons, direction and rate of seepage flow, and potential for leakage from a proposed reservoir or beneath an embankment or levee. Complex investigations are made only after a thorough analysis has been made of existing or easily acquired data. Results from ground water and foundation seepage studies provide data needed to design dewatering and seepage control systems at construction projects, indicate the potential for pollution and contamination of existing ground water resources due to project operation, show potential for interference to aquifers by the construction of a project, and determine the chemical and biological quality of ground water and that relationship to project requirements. Investigation and continued monitoring of ground water fluctuations are key dam safety issues.

a. Wells. Existing wells located during field geologic reconnaissance should be sounded or water levels obtained from the well owners. Pumping quantities, seasonal variations in ground water and pumping levels, depths of wells and screen elevations, corrosion problems, and any other relevant information should be acquired wherever available. Any settlement records attributable to ground water lowering from pumping should be obtained. This information should be compared with water well records obtained during preliminary studies to develop a complete hydrologic picture for the project area.

b. Borings. Water levels recorded on drilling logs are another source of information. However, they may not reflect true water levels, depending on soil types and time of reading after initial drilling. The influence of drilling fluids on water level readings should be kept in mind when evaluating boring data. Loss of drilling fluids can indicate zones of high permeability. Where ground water level information is needed, installation of piezometers or observation wells in borings should be considered.

c. Piezometers and observation wells. The most reliable means for determining ground water levels is to install piezometers or observation wells. Piezometers measure excess hydrostatic pressures beneath dams and embankments. All information developed during preliminary studies on the regional ground water regime should be considered in selecting locations for piezometers and observation wells. For types of piezometers, construction details, and sounding devices, refer to EM 1110-2-1908, Part 1,

and TM 5-818-5/AFM 88-5, Chapter 6/NAVFAC P-418. All piezometer borings should be logged carefully and “as built” sketches prepared that show all construction and backfill details (Figure 5-2).

(1) The selection of the screened interval is critical to the information produced, since the water level recorded will be the highest of all intervals within the screen/filter length. Careful evaluation of the conditions encountered in the hole with regard to perched or confined aquifers is essential to a sensible selection of the screened interval and interpretation of the data. One of the greatest benefits of a piezometer or observation well is that it allows for measurement of fluctuations in piezometric levels over time. To take advantage of this benefit, it is necessary to provide for periodic readings. This can be accomplished through manual reading by an automated system, depending on the location and critical importance of the area being monitored.

(2) Other information that can be derived from observation wells and piezometers are temperature and water quality data. Tracer tests can sometimes be conducted to determine the direction and rate of ground water flow.

d. Springs and surface water. The water elevation, flow rate, and temperature of all springs located within the project area should be measured. Water should be sampled for chemical analysis to establish a baseline level. Soil or rock strata at the spring should be evaluated to locate permeable horizons. Flow rates at springs should be measured during dry and wet seasons to determine the influence of rainfall on seepage conditions. The elevation of water levels in lakes and ponds should be measured during the wet and dry seasons to evaluate the extent of surface water fluctuations.

e. Geophysical methods. Geophysical methods, such as seismic refraction, can be used to determine the depth to saturated material. Depending on the accuracy required and the accuracy of the method, a minimal number of piezometers should be installed to verify the geophysical data. Surface resistivity surveys can indicate the presence of and depth to water (Society of Exploration Geophysicist 1990). Ground penetrating radar can also be used to detect the presence and location of ground water (Annan 1992). Fetter (1988) discusses these and other geophysical methods to characterize the hydrology and hydrogeology of a site.

f. Tracer testing. In some areas, especially karst terrains, it is of particular interest to determine flow paths in the ground water system. Although complex, flow paths in karst, where seepage velocities are high, can be evaluated by conducting tracer tests using either environmentally benign dyes or biological tracers such as pollen. The tracer element is introduced into a boring or other access points and monitored at an exit point such as a spring. The travel time from the introduction to detection is recorded. Numerous tests at different locations can be run and a picture of the ground water flow regime developed.

5-20. Permeability Testing

Permeabilities of foundation materials can be determined from slug and pumping tests in piezometers and wells, laboratory tests of undisturbed samples, and pressure tests in rock foundations. The permeability of sands can be roughly estimated from the D_{10} fraction (TM 5-818-5). Fracture and joint analysis is important in evaluating permeability of rock foundations. General reviews of methods to evaluate permeability of soil and rock in the subsurface include Bentall (1963), Davis and DeWiest (1966), Dawson and Istok (1991), Driscoll (1986), Fetter (1988), Heath (1983), Lohman (1972), and Walton (1970).

DRILLING LOG		DIVISION: ENVIRONMENTAL ENGINEERING		CLIENT: U.S. ARMY - APG D.S.H.E-E.M.D		SHEET 1 OF 2 SHEETS		
1. PROJECT: FTA WESTERN BOUNDARY INVESTIGATION				8. SCREENED INTERVAL: 45.0-50.0 FT		SCREEN TYPE GALVINIZED STEEL 0.010 IN CONTINUOUS SLOT		
2. LOCATION: WB-P1		MSPCS: 656,502 NORTHING 1,541,174 EASTING		9. SAMPLING METHOD (SOIL) (AIR) 2.0 FT SPLIT SPOON		PHOTOVAC MICROTIP HL2000		
3. COUNTY: HARFORD		STATE: MARYLAND		10. DRILLING EQUIPMENT: GUS PECHE BRAT 22R				
4. HOLE NO. (AS SHOWN IN STATE RECORDS) HA-92-0494				11. ELEVATION GROUND WATER (MEASURED FROM GROUND LEVEL) 10.7 FT MSL				
5. NAME OF DRILLER: JAMES MARSH				12. DATE HOLE: STARTED: 14 OCT 92		COMPLETED: 15 OCT 92		
6. DRILLING AGENCY: LAYNE ENVIRONMENTAL SERVICES				13. ELEVATION OF TOP OF HOLE: 40.70 FT		TOP OF RISER 43.41 FT		
7. DEPTH OF HOLE 77.0 FT				NAME OF INSPECTOR MARK A. LEWIS				
DEPTH FEET	CLASSIFICATION OF MATERIALS (DESCRIPTION) USCS	BLOW COUNTS	RECOVERY SAMPLE INTERVAL	SAT. MOIST DAMP	LITHOLOGY	WELL COMPLETION DIAGRAM	REMARKS (Drilling time, water loss, depth of weathering, ect., if significant)	DEPTH FEET
0	Light brown sandy silt						Above Ground Completion	0
5	Brown silty fine to med. sand with trace fine gravels, subangular SM						20:1 Portland Cement Bentonite Grout	5
	White to tan fine sand, poorly sorted SP							
	Tan silty fine sand, subangular SM							
	Tan fine to coarse sands, poorly sorted SP							
10	Brown sandy clay, slightly plastic SC							
15	Brown medium to coarse poorly sorted sand with some fine gravels, subrounded SP							15
20	Light brown silty clay, slight to medium plasticity CL							20
25	Yellowish orange silty fine sand, subangular SM							25
30	Brown sandy clay, medium plasticity SC							30
35	Light brown fine sand, subrounded SP						No Organic Vapor Readings Above Background in Breathing Zone	35
40							Bentonite Slurry Seal	40
45							Filter Pack #2 Sand	45

Figure 5-2. Example of a report-quality log with lithologic, blow count, moisture, and well completion information. Note that the header contains a variety of details concerning this monitoring well (Continued)

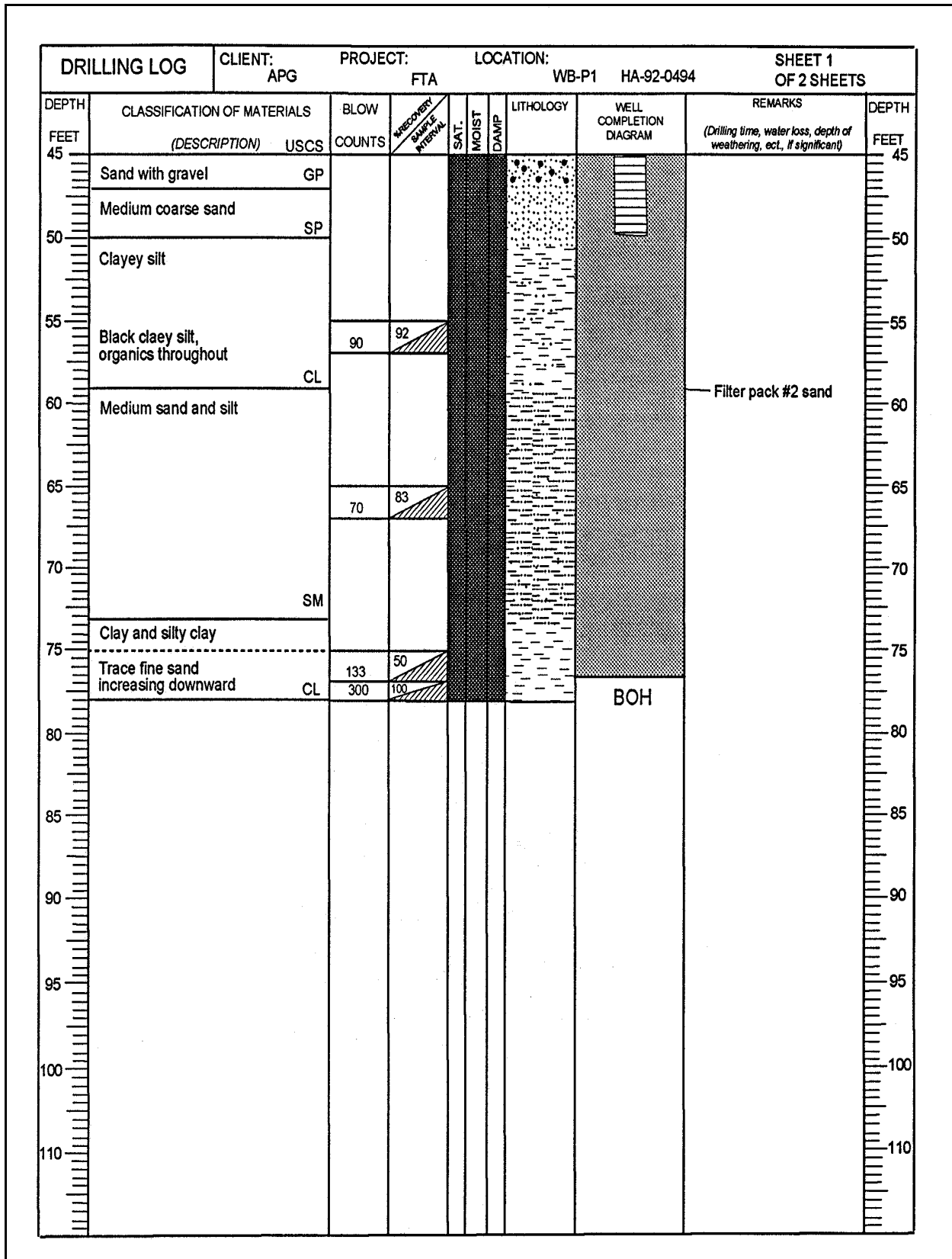

Figure 5-2. (Concluded)

a. *Tests in piezometers or wells.* Permeability tests can easily be made in piezometers or wells. They should be performed as part of piezometer installation procedures, both to obtain permeability information and to assure that the piezometer is working satisfactorily. Appropriate piezometer permeability tests are constant head, falling or rising head, and slug. The information obtained is representative of a smaller volume of material than that tested in pumping tests. However, procedures are simple, costs are low, and results may be useful if interpreted with discretion. Test details are discussed in EM 1110-2-1908 (Part 1), TM 5-818-5, U.S. Department of Interior (1977), Mitchell, Guzikowski, and Villet (1978), and Bennett and Anderson (1982).

b. *Pumping tests.* Pumping tests are the traditional method for determining permeability of sand, gravels, or rock aquifers. Observation wells should be installed to measure the initial and lowered ground water levels at various distances from the pumped well. At known or suspected HTRW sites, disposal of pumped water is a major consideration. For details of pumping tests and analyses, refer to TM 5-818-5. Pumping tests are usually desirable for the following:

- (1) Large or complex projects requiring dewatering.
- (2) Design of underseepage systems for dams or levees.
- (3) Special aquifer studies.
- (4) Projects where water supply will be obtained from wells.
- (5) Projects immediately downstream from existing embankments.

c. *Permeability of rock.* Most rock masses contain, in addition to intergranular pore spaces, complex interconnecting systems of joints, fractures, bedding planes, and fault zones that, collectively, are capable of transmitting ground water. Fracture or joint permeability is normally several magnitudes higher than the matrix permeability of the discrete blocks or masses of rock contained between the joints. The permeability of some rock masses, such as sandstones and conglomerates, is governed by interstitial voids similar to that of soils. Secondary weathering and solutioning of limestones and dolostones may produce large void spaces and exceptionally high permeabilities. Although the permeability of rock results from interconnecting systems of joints, fractures, and formational voids, the equivalent rock mass permeability can frequently be modeled as a uniform porous system. Although it is necessary to keep the hydrologic model manageable, the shortcoming of this approach is that most rock masses are anisotropic with regard to permeability. The influence of this on a practical level is that it is easy to over- or underestimate the ground water effects in rock. As an example, if a pumping test is conducted with monitoring wells oriented along a line perpendicular to the predominant water-bearing joint set, the results will underestimate the radius of influence along the joint set. Therefore, the layout of pumping tests must be well thought out beforehand. At least a preliminary fracture and joint analysis should be conducted prior to laying out a pump test.

d. *Fracture and joint analysis.* Because joint or fracture permeability frequently accounts for most of the flow of water through rocks, an accurate description of in situ fracture conditions of a rock mass is critical to predicting performance of drains, wells, and piezometer responses. Joints typically occur in sets which have similar orientations. There may be three or more sets of joints in a rock mass. Joint sets that occur in the rock mass at the site should be identified and the preferred orientation and range in orientation of each joint set recorded. Features such as joint orientation, spacing, joint width, and the degree and type of secondary mineral filling should be carefully noted for each joint set. Once all joint

sets of a site have been identified and evaluated, their relative importance to ground water flow should be assessed. Joints and fractures can be evaluated by developing the structure and stratigraphy of the site from accessible outcrops and from borehole logs.

5-21. Pressure Tests

a. Pressure tests are performed to measure the permeability of zones within rock masses. Pressure test results are used in assessing leakage in the foundation and as a guide in estimating grouting requirements. Pressure tests are typically conducted during exploratory core drilling and are a relatively inexpensive method of obtaining important hydrogeologic information about a rock mass. Hydraulic pressure testing should be considered an integral part of the exploratory core drilling process in all cases where rock seepage characteristics could affect project safety, feasibility, or economy. The testing interval is typically 1.5 to 3 m (5 to 10 ft) but may be varied to fit specific geological conditions observed during the core drilling operations. Zones to be tested should be determined by (1) examining freshly extracted cores, (2) noting depths where drilling water was lost or gained, (3) noting drill rod drop, (4) performing borehole or TV camera surveys, and (5) conducting downhole geophysical surveys. In rock with vertical or high angle joints, inclined borings are necessary to obtain meaningful results. Types of tests and test procedures are described in Ziegler (1976), U.S. Department of Interior (1977), and Bertram (1979).

b. Pressures applied to the test section during tests should normally be limited to 23 kilo Pascals (kP) per meter (1 psi per foot) of depth above and 13 kP/meter (0.57 psi/foot) of depth below the piezometric surface. The limit was established to avoid jacking and damage to rock formations. The limit is conservative for massive igneous and metamorphic rocks. However, it should be closely adhered to for tests in horizontally bedded sedimentary and other similar types of formations. Naturally occurring excess water pressures (artesian) should be taken into account in computations for limiting test pressures. Where the test intervals are large, a reduction in total pressure may be necessary to prevent jacking of the formation within the upper portion of the test section.

c. An important, but often unrecognized, phenomenon in pressure testing is joint dilation and contraction as pressure is applied and released. In the case of a dam project, it is desirable to use pressures that will correspond to future reservoir conditions. Joint dilation can frequently be observed by conducting a "holding" test. The fall in pressure is observed and a plot of pressure versus time is made. The pressure should quickly drop to near the surrounding piezometric level if the joint openings remain the same width. The common observation of a slow pressure decay in pressure holding tests indicates joint closure with reduction in pressure.

d. Qualitative evaluations of leakage and grout requirements can be made from raw pressure test data (Ziegler 1976, U.S. Department of Interior 1977, Bertram 1979). Most analyses of this type assume laminar flow rather than turbulent flow. This assumption can be verified by conducting pressure tests on the same interval at several different pressures. If the water take is directly proportional to the total applied pressure, laminar flow can be assumed. If pressure test data are converted into values of equivalent permeability or transmissivity, calculations can be performed to estimate seepage quantities. Wherever possible, such results should be compared with data from completed projects where similar geologic conditions exist.

Section VI
In situ Testing to Determine Geotechnical Properties

5-22. In Situ Testing

In situ tests are often the best means for determining the engineering properties of subsurface materials and, in some cases, may be the only way to obtain meaningful results. Table 5-2 lists in situ tests and their purposes. In situ rock tests are performed to determine in situ stresses and deformation properties (moduli) of the jointed rock mass, shear strength of jointed rock masses or critically weak seams within the rock mass, and residual stresses along discontinuities or weak seams in the rock mass. Pressure tests have been discussed in Section V (paragraph 5-20) of this manual.

Table 5-2
In Situ Tests for Rock and Soil

Purpose of Test	Type of Test	Applicability to	
		Soil	Rock
Shear strength	Standard penetration test (SPT)	X	
	Field vane shear	X	
	Cone penetrometer test (CPT)	X	
	Direct shear	X	
	Plate bearing or jacking	X	X ¹
	Borehole direct shear ²	X	
	Pressuremeter ²		X
	Uniaxial compressive ²		X
Bearing capacity	Borehole jacking ²		X
	Plate bearing	X	X ¹
Stress conditions	Standard penetration	X	
	Hydraulic fracturing	X	X
Mass deformability	Pressuremeter	X	X ¹
	Overcoring		X
	Flatjack		X
	Uniaxial (tunnel) jacking	X	X
	Borehole jacking ²		X
	Chamber (gallery) pressure ²		X
	Geophysical (refraction)	X	X
	Pressuremeter or dilatometer	X	X ¹
Relative density	Plate bearing	X	X
	Standard penetration	X	
	Uniaxial (tunnel) jacking	X	X
	Borehole jacking ²		X
	Chamber (gallery) pressure ²		X
	Standard penetration	X	
	In situ sampling	X	
Liquefaction susceptibility	Cone ² penetrometer	X	
	Standard penetration	X	
	Cone penetrometer test (CPT) ²	X	

¹ Primarily for clay shales, badly decomposed, or moderately soft rocks, and rock with soft seams.

² Less frequently used.

a. *Soils, clay shales, and moisture-sensitive rocks.* Interpretation of in situ tests in soils, clay shales, and moisture-sensitive rocks requires consideration of the drainage that may occur during the test. Consolidation during testing makes it difficult to determine whether the test results correspond to unconsolidated-undrained, consolidated-undrained, consolidated-drained conditions, or intermediate conditions between these limiting states. The cone penetrometer test is very useful for detecting soft or weak layers and in quantifying undrained strength trends with depth. Interpretation of in situ test results

requires complete evaluation of the test conditions and the limitations of the test procedure. ASTM D 3877-80 (ASTM 1996h) is the standard laboratory method for evaluating shrink/swell of soils due to subtraction or addition of water.

b. Rock. Rock formations are generally separated by natural joints, bedding planes, and other discontinuities resulting in a system of irregularly shaped blocks that respond as a discontinuum to various loading conditions. Response of a jointed rock mass to imposed loads involves a complex interaction of compression, sliding, wedging, rotation, and possibly fracturing of individual rock blocks. Individual blocks generally have relatively high strengths, whereas the strength along discontinuities is normally reduced and highly anisotropic. Commonly, little or no tensile strength exists across discontinuities. As a result, resolution of forces within the system generally cannot be accomplished by ordinary analytical methods. Large-scale, in situ tests tend to average out the effect of complex interactions. In situ tests in rock are generally expensive and should be reserved for projects with large, concentrated loads. Well-conducted tests, however, may be useful in reducing overly conservative, costly assumptions. Such tests should be located in the same general area as a proposed structure and test loading should be applied in the same direction as the proposed structural loading.

5-23. In situ Tests to Determine Shear Strength

Table 5-3 lists in situ tests that are useful for determining the shear strength of subsurface materials. In situ shear tests are discussed and compared by Nicholson (1983b) and Bowles (1996).

Table 5-3
In Situ Tests to Determine Shear Strength

Test	For		Reference	Remarks
	Soils	Rocks		
Standard penetration	X		EM 1110-2-1906 Appendix C	Use as index test only for strength. Develop local correlations. Unconfined compressive strength in tons/square foot is often 1/6 to 1/8 of N-value
Direct shear	X	X	RTH 321 ¹	Expensive; use when representative undisturbed samples cannot be obtained
Field vane shear	X		EM 1110-2-1906, Appendix D, Al-Khafaji and Andersland (1992)	Use strength reduction factor
Plate bearing	X	X	ASTM ² Designation D 1194 ASTM SPT 479 ³	Evaluate consolidation effects that may occur during test
Uniaxial compression		X	RTH 324 ¹	Primarily for weak rock; expensive since several sizes of specimens must be tested
Cone penetrometer test (CPT)	X		Schmertmann (1978a); Jamiolkowski et al. (1982)	Consolidated undrained strength of clays; requires estimate of bearing factor, N_c

¹ Rock Testing Handbook (USAEWES 1993).

² American Society for Testing and Materials (ASTM 1996a).

³ Special Technical Publication 479 (ASTM 1970).

a. *The Standard Penetration Test (SPT).* The SPT is useful for preliminary appraisals of a site (Bowles 1996). The N-value has been empirically correlated with liquefaction susceptibility under seismic loadings (Seed 1979). The N-value is also useful for pile design. In cohesive soils, the N-value can be used to determine where undisturbed samples should be obtained. The N-value can also be used to estimate the bearing capacity (Meyerhof 1956; Parry 1977), the unconfined compressive strength of soils (Mitchell, Guzikowski, and Villet 1978), and settlement of footings in soil (Terzaghi, Peck, and Mesri 1996).

b. *The Becker Penetration Test.* The Becker drill (paragraph 5-5(2)) provides estimates of in situ soil strength and other properties similarly to the SPT, including coarse grained soils like gravel. The Becker penetration test was described in Harder and Seed (1986). The test consists of counting the number of hammer blows required to drive the casing 1 ft into the soil, for each foot of penetration. The test uses both open casing and plugged bits, commonly with a 14-cm (5.5-in.) or 17-cm (6.6-in.) OD casing and bits. Correlations of Becker blowcounts with SPT blowcounts have been developed to allow the use of Becker data in foundation investigations and in evaluation of liquefaction potential in coarse-grained soils under seismic loading.

c. *Direct shear tests.* In situ direct shear tests are expensive and are performed only where doubt exists about available shear strength data and where thin, soft, continuous layers exist within strong adjacent materials. The strength of most rock masses, and hence the stability of structures, is often controlled by the discontinuities separating two portions of the rock mass. Factors controlling the shear of a discontinuity include the loads imposed on the interface, the roughness of the discontinuity surfaces, the nature of the material between the rock blocks, and the pore water pressure within the discontinuity (Nicholson 1983b). In situ direct shear tests measure the shear strength along a discontinuity surface by isolating a block of rock and the discontinuity, subjecting the specimen to a normal load perpendicular to and another load (the shear load) parallel to the plane. The advantages of the direct shear test are: (1) its adaptability to field conditions, i.e., a trench, an adit, a tunnel, or in a calyx hole; (2) it is ideal for determining discontinuity shear strength because the failure plane and direction of failure are chosen before testing, accommodating anisotropic conditions; and (3) it allows for volume increases along the failure plane. Disadvantages of direct shear tests are their expense, the fact that they measure strength along only one potential failure plane, and the sometimes nonuniform application of normal stress during shearing. For the latter reasons, some engineers favor the triaxial compression test, which also can be performed in situ, for determination of shear strength (Ziegler 1972). The direct shear test measures peak and residual strength as a function of stress normal to the shear plane. Results are usually employed in limiting equilibrium analysis of slope stability problems or for stability analysis of foundations for large structures such as dams. Where field evidence suggests that only residual strengths can be relied on, either in a thin layer or in a mass, because of jointing, slickensiding, or old shear surfaces, in situ direct shear tests may be necessary. Few in situ direct shear tests are performed on soils, but they may be justified on clay shales, indurated clays, very soft rock, and on thin, continuous, weak seams that are difficult to sample. Ziegler (1972) and Nicholson (1983a,b) discuss the principles and methods of performing in situ direct shear tests. The Rock Testing Handbook (RTH) method RTH 321-80 (USAEWES 1993) provides the suggested method for determining in situ shear strength using the direct shear apparatus.

d. *Field vane shear tests.* Field vane tests performed in boreholes can be useful in soft, sensitive clays that are difficult to sample. The vane is attached to a rod and pushed into the soft soil at the bottom of the borehole. The assembly is rotated at a constant rate and the torque measured to provide the unconsolidated, undrained shear strength. The vane can be reactivated to measure the ultimate or residual strength (Hunt 1984). The vane shear test results are affected by soil anisotropy and by the

presence of laminae of silt or sand (Terzaghi, Peck, and Mesri 1996). Shear is applied directionally. Failure of the soil occurs by shearing of horizontal and vertical surfaces. See Al-Khafaji and Andersland (1992) for a discussion of effects of soil anisotropy. The test may give results that are too high. Factors to correct the results are discussed in Bjerrum (1972) and Mitchell, Guzikewski, and Villet (1978). The test has been standardized as ASTM method D 2573 (ASTM 1996e).

e. Plate bearing tests. Plate bearing (plate-load) tests can be made on soil or soft rock. They are used to determine subgrade moduli and occasionally to determine strength. The usual procedure is to jack-load a 30- or 76-cm (12- or 30-in.) diam plate against a reaction to twice the design load and measure the deflection under each loading increment. The subgrade modulus is defined as the ratio of unit pressure to unit deflection, or force/length³ (Hunt 1984). Because of their cost, such tests are normally performed during advanced design studies or during construction.

f. Cone penetrometer test or dutch cone. The Cone Penetrometer Test (CPT) can provide detailed information on soil stratigraphy and preliminary estimations of geotechnical properties. Based on the soil type as determined by the CPT (Douglas and Olsen 1981) or adjacent boring, the undrained strength can be estimated for clays (Jamiolkowski et al. 1982, Schmertmann 1970), and the relative density (and friction angle) estimated for sands (Durgunoglu and Mitchell 1975; Mitchell, Guzikewski, and Villet 1978; Schmertmann 1978b). For clays, a bearing factor, N_c , must be estimated to calculate the undrained strength from the CPT cone resistance and should be close or slightly greater than the CPT sleeve friction resistance if the soil is not sensitive or remolded (Douglas and Olsen 1981). The calculated undrained strength as well as the change of undrained strength with depth can both be used with several techniques to estimate the overconsolidation ratio (OCR) (Schmertmann 1978a). For sands, the relative density can be estimated if the overconsolidation conditions (i.e., lateral stress ratio) and vertical effective stress are known. The friction angle can also be estimated but also depends on the cone surface roughness and the assumed failure surface shape (Durgunoglu and Mitchell 1975). The mechanical (i.e., Dutch) cone is performed at a depth interval of 20 cm (8 in.) using hydraulic gages which measure the force from an inner rod directly in contact with the end of the probe. The electric (PQS or VGRO) cone is pushed at a constant speed for 1-m intervals while electronically measuring cone and friction resistance continuously.

5-24. Tests to Determine In Situ Stress

Table 5-4 lists the field tests that can be used to determine in situ stress conditions. The results are used in finite element analyses, estimating loading on tunnels, determining rock burst susceptibility in excavations, and identifying regional active and residual stresses. Stresses occur as a result of gravity forces, actively applied geologic forces such as regional tectonics, and from stored residual-strain energy. Stress is measured to determine the effect on foundations of changes in loading brought about by excavation or construction. Where a confining material has been removed by natural means or by excavation, the remaining material tends to approach a residual state of stress. In a majority of projects, the major principal stress is vertical, i.e., the weight of the overlying material. However, it has been found from measurements made throughout the world that horizontal stresses in the near-surface vicinity, defined as 30 m (100 ft) or less, can be one and one-half to three times higher than the vertical stress. Recognition of this condition during the design phase of investigations is very important. Where high horizontal stresses occur at a project site, the stability of cut slopes and tunnel excavations is affected. In situ testing is the most reliable method for obtaining the magnitude and direction of stresses. The three most common methods for determining in situ stresses are the overcoring, hydrofracture, and flatjack techniques.

**Table 5-4
In Situ Tests to Determine Stress Conditions**

Test	Soils	Rocks	Bibliographic Reference	Remarks
Hydraulic fracturing	X		Leach (1977) Mitchell, Guzikowski, and Villet (1978)	Only for normally consolidated or slightly consolidated soils
Hydraulic fracturing		X	RTH 344 ¹ Goodman (1981) Hamison (1978)	Stress measurements in deep holes for tunnels
Vane shear	X		Blight (1974)	Only for recently compacted clays, silts
Overcoring techniques		X	RTH 341 ¹ Goodman (1981) Rocha (1970)	Usually limited to shallow depth in rock
Flatjacks		X	RTH 343 ¹ Deklotz and Boisen (1970) Goodman (1981)	
Uniaxial (tunnel) jacking	X	X	RTH 365 ¹	May be useful for measuring lateral stresses in clay shales and rocks, also in soils
Pressuremeter (Menard)	X		Al-Khafaji and Andersland (1992), Hunt (1984)	

¹ Rock Testing Handbook (USAEWES 1993).

a. Overcoring method. Possibly the most common method used for measuring in situ stresses in rock is overcoring, a stress-relief technique. An NW (75.7 mm (2.980 in.)) core hole is drilled, instrumented, and redrilled with a larger core barrel. The overcoring decouples the rock surrounding the instrument package from the natural stress field of the in-place formation. The change in strain recorded by the instruments is then converted to stress by using the elastic modulus of the rock determined from laboratory tests. At least three separate tests must be made in the rock mass in nonparallel boreholes. A detailed description of the field test is provided by RTH 341-80 (USAEWES 1993). The overcoring method is hampered by the necessity for many instrument lead wires that may be broken during testing. The practical maximum depth of testing is usually less than 45 m (150 ft).

b. Flatjack method. In the flatjack method, a slot is bored or cut into the rock wall midway between two inscribed points. Stresses present in the rock will tend to partially close the slot. A hydraulic flatjack is then inserted and grouted into the slot, and the rock is jacked back to its original position as determined by the inscribed points. The unit pressure required is a measure of the in situ stress. Flatjacks installed at different orientations provide a measure of anisotropy (Hunt 1984). The value recorded must be corrected for the influence of the tunnel excavation itself. Flatjack tests require an excavation or tunnel. The high cost for constructing the opening usually precludes this technique as an indexing tool except where the size of the structure and complexity of the site dictate its use.

c. Hydrofracture method. The hydrofracture method has been used in soils and rock. A section of hole is isolated with packers at depth, and an increasingly higher water pressure is applied to the zone. A point will be reached where the pressure begins to level off, and there is a marked increase in water take.

This indicates that a crack in the formation has opened, and the threshold pressure has been reached. The threshold pressure measures the minor principal stress component. The orientation is then obtained by an impression packer. This procedure then gives the intensity and direction of the minor principal stress, which is perpendicular to the crack. The hydrofracture method has no particular depth limitation, but drilling deep holes can be very expensive. This expense can often be circumvented by using holes that have been drilled for other purposes. Evidence indicates that stresses measured within 30 m (100 ft) or more of ground surface may not always reflect the actual stress magnitude or orientation at depth. This may be true particularly in areas where closely jointed and weathered surface rock formations are decoupled from the deeper, more intact rock.

5-25. Tests to Determine In Situ Deformation

Deformation characteristics of subsurface materials are of major importance in dynamic and seismic analyses for dams and other large structures, static design of concrete gravity and arch dams, tunnels, and certain military projects. Geotechnical investigations for such purposes should be planned jointly by geotechnical personnel and structural engineers. Deformation properties are normally expressed in terms of three interdependent parameters: Young's modulus, shear modulus, and Poisson's ratio. These parameters assume that materials are linear, elastic, homogeneous, and isotropic. In spite of this limitation, these parameters are often used to describe the deformation properties of soil and rock. Large-scale tests (e.g., tunnel jacking) are frequently used because they reduce the effect of nonhomogeneity. Multiple tests, with different orientations, can be used to determine the anisotropy of the deformation properties. Soils, in particular, tend to be nonlinear and inelastic. As a result, their properties are often strain dependent, i.e., moduli determined at low strain levels can be substantially different from those determined at high strain levels. The fact that sample disturbance, particularly in soils, can substantially affect the deformation properties serves as the primary reason for using in situ tests in soils. Table 5-5 lists the in situ tests used to determine one or more of the deformation parameters. Some test results are difficult to relate to the fundamental parameters but are used directly in empirical relationships (Table 5-6). Deformation properties of a jointed rock mass are very important if highly concentrated loadings are directed into the abutments of arch dams in directions that are tangent to the arches at the abutments. In these cases, the ratio of the deformation modulus of the abutment rock to that of the concrete in the dam must not be so low as to cause adverse tensile stresses to develop within the concrete dam. One problem often encountered in conducting in situ deformation tests is the need to include representative sizes of the jointed rock mass in the test, particularly if the joint spacing is moderately large (e.g., 0.6 to 0.9 m or 2 to 3 ft). This problem has been solved in some instances by excavating a chamber in rock, lining it with an impermeable membrane, and subjecting it to hydraulic pressure to load the rock over relatively large areas.

a. Chamber tests. Chamber tests are performed in large underground openings, such as exploratory tunnels. Preexisting openings, such as caves or mine chambers, can be used if available and applicable to project conditions. The opening is lined with an impermeable membrane and subjected to hydraulic pressure. Instrumented diametrical gages are used to record increases in tunnel diameter as the pressure load increases. The test is performed through several load-unload cycles. The data are subsequently analyzed to develop load-deformation curves from which a deformation modulus can be selected. The results are usually employed in the design of dam foundations and for the proportioning of pressure shaft and tunnel linings. The chamber test method is described by RTH 361-89 (USAEWES 1993).

**Table 5-5
In Situ Tests to Determine Deformation Characteristics**

Test	For		Reference	Remarks
	Soils	Rocks		
Geophysical refraction, cross-hole and downhole	X	X	EM 1110-1-1802	For determining dynamic Young's Modulus, E, at the small strain induced by test procedure. Test values for E must be reduced to values corresponding to strain levels induced by structure or seismic loads
Pressuremeter	X	X	RTH 362 ¹ Baguelin, Jezequel, and Shields (1978) Mitchell, Guzikowski, and Villet (1978)	Consider test as possibly useful but not fully evaluated. For soils and soft rocks, shales, etc.
Chamber test	X	X	Hall, Newmark, and Hendron (1974) Stagg and Zienkiewicz (1968)	
Uniaxial (tunnel) jacking	X	X	RTH 365 ¹ Stagg and Zienkiewicz (1968)	
Flatjacking		X	RTH 343 ¹ Deklotz and Boisen (1970) Goodman (1981)	
Borehole jack or dilatometer		X	RTH 363 ¹ Stagg and Zienkiewicz (1968)	
Plate bearing		X	RTH 364 ¹ ASTM STP 479 ² Stagg and Zienkiewicz (1968)	
Plate bearing	X		MIL-STD 621A, Method 104	
Standard penetration	X		Hall, Newmark, and Hendron (1974)	Correlation with static or effective shear modulus, in Mpa (psi), of sands; settlement of footings on clay. Static shear modulus of sand is approximately: $G_{eff} = 1960 N^{0.51}$ in Mpa (psi); N is SPT value

¹ Rock Testing Handbook (USAEWES 1993).

² American Society for Testing and Materials, Special Technical Publication 479 (ASTM 1970).

**Table 5-6
Correlations Between Field Tests for Soils, Material Characteristics, and Structural Behavior**

Field Test	Correlation With	Remarks
1 x 1-ft plate load test	Modulus of subgrade reaction. Settlement of footings on sand	Mitchell, Guzikowski, and Villet (1978)
Load test for radar towers	Young's modulus of subgrade soils	MIL-STD-621A
Standard penetration N-value	Settlement of footings and mats on sand; shear modulus	TM 5-818-1; Hall, Newmark, and Hendron (1974) Meyerhof (1956) Parry (1977) U.S. Army Engineer Waterways Experience Station (1954)
Cone penetrometer test	ö of sands; settlement of footings on sand; relative density	Mitchell, Guzikowski, and Villet (1978) Mitchell and Lunne (1978) Schmertmann (1978b) Durgunoglu and Mitchell (1975) Schmertmann (1970) Schmertmann (1978a,b)

b. Uniaxial jacking test. An alternative to chamber tests is the uniaxial jacking test (RTH 365-80 (USAEWES 1993)). The test uses a set of diametrically opposed jacks to test large zones of soil and rock. This method produces nearly comparable results with chamber tests without incurring the much greater expense. The test determines how foundation materials will react to controlled loading and unloading cycles and provides data on deformation moduli, creep, and rebound. The uniaxial jacking test is the preferred method for determining deformation properties of rock masses for large projects.

c. Other deformation tests. Other methods for measuring deformation properties of in situ rock are anchored cable pull tests, flatjack tests, borehole jacking tests, and radial jacking tests. The anchored cable pull test uses cables, anchored at depth in boreholes, to provide a reaction to large slabs or beams on the surface of the rock. The test is expensive and difficult to define mathematically but offers the advantages of reduced shearing strains and larger volumes of rock being incorporated in the test. Flatjack tests are flexible, and numerous configurations may be adopted. In relation to other deformation tests, the flatjack test is relatively inexpensive and useful where direct access is available to the rock face. Limitations to the method involve the relatively small volume of rock tested and the difficulty in defining a model for calculation of deformation or failure parameters.

(1) The borehole jack (“Goodman” jack), or dilatometer, and the Menard pressuremeter (Terzaghi, Peck, and Mesri 1996; Al-Khafaji and Andersland 1992; and Hunt 1984), which are applied through a borehole, have the primary advantage that direct access to the rock or soil face is not required. The dilatometer determines the deformability of a rock mass by subjecting a section of a borehole to mechanical jack pressure and measuring the resultant wall displacements. Elastic and deformation moduli are calculated. The pressuremeter performs a similar operation in soils and soft rock. The development of a mathematical model for the methods has proved to be more difficult than with most deformation measurement techniques.

(2) Radial jacking tests (RTH 367-89 (USAEWES 1993)) are similar in principle to the borehole jacking tests except that larger volumes of rock are involved in the testing. Typically, steel rings are placed within a tunnel with flatjacks placed between the rings and the tunnel surfaces. The tunnel is loaded radially and deformations are measured. The method is expensive but useful and is in the same category as chamber tests. All methods of deformation measurements have inherent advantages and disadvantages, and thus selection of test methods must be dictated by the nature of the soil or rock mass, the purpose of the test, and the magnitude of the project. Care must be exercised and limitations recognized in the interpretation and use of measurements of deformation.

5-26. Determination of Dynamic Moduli by Seismic Methods

Seismic methods, both downhole and surface, are used on occasion to determine in-place moduli of soil and rock (see Table 5-2). The compressional wave velocity is mathematically combined with the mass density to estimate a dynamic Young's modulus, and the shear wave velocity is similarly used to estimate the dynamic rigidity modulus. However, because particle displacement is so small and loading is transitory during these seismic tests, the resulting modulus values tend to be too high. The seismic method of measuring modulus should not be used in cases where a reliable static modulus value can be obtained. Even where the dynamic modulus is to be used for earthquake analyses, the modulus derived from seismic methods is too high. The moduli and damping characteristics of rock are strain dependent, and the strains imposed on the rock during seismic testing are several orders of magnitude lower than those imposed by a significant earthquake. Generally, as the strain levels increase, the shear modulus and Young's modulus decrease and the damping increases. Consideration of these factors is necessary for earthquake analyses.

Section VII
Backfilling of Holes and Disposition of Samples and Cores

5-27. Backfilling Boreholes and Exploratory Excavations

Except where the hole is being preserved for future use, all boreholes and exploratory excavations should be backfilled. The reasons for backfilling holes are to: eliminate safety hazards for personnel and animals, prevent contamination of aquifers, minimize underseepage problems of dams and levees, and minimize adverse environmental impacts. Many states have requirements regarding backfilling boreholes; therefore, appropriate state officials should be consulted. Holes preserved for the installation of instrumentation, borehole examination, or downhole geophysical work should be backfilled when no longer needed. As a minimum, borings that are preserved for future use should be protected with a short section of surface casing, capped, and identified. Test pits, trenches, and shafts should be provided with suitable covers or barricades until they are backfilled. Where conditions permit, exploratory tunnels may be sealed in lieu of backfilling. Procedures for backfilling boreholes and exploratory excavations are discussed in Appendix F, Chapter 10, of this manual.

5-28. Disposition of Soil Samples

Soil samples may be discarded once the testing program for which they were taken is complete. Geotechnical samples of soil and/or rock collected from areas suspected of containing HTRW *should be properly disposed of*. Soil samples are not normally retained for long periods, because even the most careful sealing and storing procedures cannot prevent the physical and chemical changes that, in time, would invalidate any subsequent test results. Requirements for the disposition of soil samples from plant pest quarantined areas are specified in ER 1110-1-5.

5-29. Disposition of Rock Cores

All exploratory and other cores not used for test purposes shall be properly preserved, boxed, and stored in a protected storage facility until disposal. The following procedures govern the ultimate disposition of the cores.

a. Care and storage. Filled core boxes can be temporarily protected at the drilling site by wrapping them in plastic sheeting and preventing direct contact of the boxes with the ground. Exploratory or other cores, regardless of age, will be retained until the detailed logs, photographs, and test data have been made a matter of permanent record. Precautions shall be taken to ensure against the disposal, destruction, or loss of cores that may have a bearing on any unsettled claim. Such cores shall be retained until final settlement of all obligations and claims. They then will be disposed of in accordance with the procedures outlined in the following text.

b. Disposal. Cores over 15 cm (6 in.) in diameter may be discarded after they have served their special purpose. Geotechnical samples of soil and/or rock collected from areas suspected of containing HTRW *should be properly disposed of*. In a case where the project is deauthorized, all associated cores may be discarded. When a project has been completed and final settlement has been made with the contractors and others concerned, all cores, except those related to future construction, and a few selected cores representative of foundation and abutment conditions, may be discarded. Selected cores, retained after the completion of a project, and additions thereto, may be discarded or otherwise disposed of 5 years after final completion of the project, provided no unforeseen foundation or abutment conditions have developed. After cores are disposed of, core boxes should be salvaged for reuse if their condition permits.

Chapter 6 Large-scale, Prototype Investigations

6-1. Prototype Test Programs

Whenever the size and complexity of a project warrant, large-scale, prototype test programs can yield information unavailable by any other method. Because these investigations are expensive and require the services of a construction contractor in most cases, they are commonly included as part of a main contract to confirm design assumptions. However, if performed during the PED phase, they can provide a number of benefits that will result in an improved, more cost-effective design. These benefits include: confirmation of assumptions for new or innovative design, improved confidence level allowing reduced safety factors, proof of constructibility, confirmation of environmental compliance, and greater credibility in allaying public concerns. Evaluation of the potential for savings and benefits should be made by an experienced engineering geologist or geotechnical engineer. A major pit-fall of the large-scale prototype test is that it is commonly difficult, if not impossible, to precisely follow the same procedures in the main contract that were used in the test. This does not eliminate the benefits to be gained but should be kept in mind when deciding how to incorporate the information into a bid package.

Section I

Test Excavations and Fills

6-2. Accomplishments

In most cases, a test excavation or fill technique such as blasting and rippability accomplishes one or more of the following requirements: (a) evaluates the suitability of specialized construction equipment such as coal saws or vibratory rollers; (b) investigates the influence of material properties on construction products such as blasted rock gradations; (c) provides the opportunity for preconstruction monitoring of ground reactions to test design assumptions; (d) more completely discloses the geologic conditions; (e) investigates material placement properties and procedures; (f) investigates environmental impacts such as blasting vibrations or ground water lowering; and (g) provides access to install initial ground support and instrumentation.

6-3. Test Quarries

Test quarries are usually implemented in conjunction with test fill programs and in areas where large quantities of rock material will be needed from undeveloped sources. EM 1110-2-2301 discusses test quarry and test fill evaluation procedures. Test quarries are especially important where there are serious questions about the suitability of rock in required excavations for use in embankment rock-fill zones or for slope protection. In addition to providing material for rock test fills, test quarries provide information on cut slope design constraints resulting from adverse geologic structure, suitable blasting techniques, suitability of quarry-run rock, and the feasibility and best methods for processing materials. The results of quarry tests can provide designers and prospective bidders with a much better understanding of drilling and blasting characteristics of the rock. Although useful information is gained from a well conducted test quarry program, it is an expensive type of investigation. If possible, a test quarry should be located in an area of required excavation. Excess materials from the test quarry can be stockpiled for later use. Determining the optimum methods of precision slope development (e.g., best presplitting blasthole spacing and powder factors) can be an important part of the test quarry program. This determination ensures maximum side slope stability by minimizing overbreakage. Mapping of test

quarry slopes, in conjunction with the use of slope stability analysis programs such as ROCKPACKII (Watts 1996) and Discontinuous Deformation Analysis Program (International Forum on Discontinuous Deformation Analysis and Simulations of Discontinuous Media 1996), can provide needed geologic data for use in design of permanent slopes. To be of maximum benefit, the test quarry should be located in a portion of the excavation area that is representative of the geologic conditions to be encountered.

a. Geologic study. Before a test quarry program is undertaken, a careful geologic study should be made of the test quarry site. The geologic study should include:

(1) Field reconnaissance and mapping of exposed rock jointing and discontinuities.

(2) Examination of boring logs, rock cores, and borehole survey results to determine depth of overburden and weathered rock, joint patterns, presence of filled solution joints or fault zones, and ground water conditions that could affect blasting operations.

(3) Consideration of regional stress fields and site-specific stress conditions that could affect stress relief in joints during quarrying operations.

(4) Development of geologic sections and profiles depicting rock type and stratum thickness, joint spacing, frequency and orientation, filled joint systems, and other discontinuities that would influence rock breakage and the amount of fines.

(5) Consideration of all other factors that may control size, quantity, and quality of blasted rock (e.g., proximity to structures or urban areas where blast size, airblast, ground vibrations, or fly rock may have to be rigidly controlled).

b. Test objectives. Once geologic studies indicate that a quarry source can produce an adequate quality and quantity of fill and construction material and the range of aggregate size has been determined, other data needed for test quarry design purposes include overall gradation, yield, quality, and production. Blasting techniques and modifications to fit geologic conditions are discussed in EM 1110-2-3800. The upper fragment size is determined by the geologic conditions and rock structure. Other sizes and gradations can be controlled partially by the blasting techniques.

c. Test program. In a well-planned test quarry program, many of the blasting variables, such as blasthole spacing, patterns, and firing sequences, powder brisance, powder factor, and bench height, are subjected to field experimentation. The program should be developed and supervised by an experienced geologist or geotechnical engineer. By dividing the test quarry into separate tests, each of the variables can be evaluated separately while the others are held constant. For each test, the blasted rock must be gathered, sieved, and weighed to obtain gradations. For aggregate studies, representative samples should be taken for processing, testing, and mix design. If blasted rock is also being used for rock test fills, it may be necessary to use representative truck loads for gradation processing. As individual test blasts are completed and gradations determined, modifications to the blasting technique can be made. When all individual test blasts and associated gradations are completed, the data should be reviewed to determine which set of blasting parameters best fulfills design requirements. Test quarry programs are discussed in EM 1110-2-2301, Bechtell (1975), Lutton (1976), and Bertram (1979).

d. Application. The results of test quarry programs are expressed in terms of optimum blasting patterns, powder factors, blasthole sizes, firing delay sequences, yields, and gradations. These results, combined with results of test fills, form a valuable source of data for the quarry designer. This

information is equally valuable to prospective contractors and should be provided for information in the plans and specifications.

6-4. Exploratory Tunnels

Exploratory tunnels permit detailed examination of the composition and geometry of rock structures such as joints, fractures, faults, shear zones, other discontinuities, and solution channels. They are commonly used to explore conditions at the locations of large underground excavations and the foundations and abutments for large dams. They are particularly appropriate in defining the extent of marginal strength rock or adverse rock structure suspected from surface mapping and boring information. For major projects where high-intensity loads will be transmitted to foundations or abutments, tunnels afford the only practical means for testing in-place rock at locations and in directions corresponding to the structural loading. Although expensive, exploratory tunnels provide exceptionally good preconstruction information to perspective contractors on major underground projects and can reduce bid contingencies and/or potential for claims. Long horizontal exploratory drill holes can also be used in lieu of, or in combination with, pilot tunnels to gather information about tunneling conditions prior to mining.

a. In the case of planned underground construction, an exploratory tunnel is often used to gain access to crown and roof sections of future large underground excavations. The tunnel can then be used during construction for equipment access and removal of excavated rock. A small bore or exploratory “pilot” tunnel is sometimes driven along the entire length of a proposed larger-diameter tunnel where difficult and often unpredictable ground conditions are anticipated. A pilot tunnel may be the most feasible alternative for long deep tunnels where deep exploratory drilling and access for in situ testing from the ground surface is prohibitively expensive. The pilot tunnel can be positioned to allow installation of roof support and/or consolidation grouting for critical areas of the full tunnel, or in some cases, to provide relief or “burn cuts” to facilitate blasting. Exploratory tunnels that are strategically located commonly can be incorporated into the permanent structure. They can be used for drainage and postconstruction observations to determine seepage quantities and to confirm certain design assumptions. On nonwater related projects, exploratory tunnels may be used for permanent access or for utility conduits. One concern, however, is not to position the pilot tunnel too close to the projected crown excavation neat line of the full-sized tunnel. If this occurs, overbreak in the crown of the tunnel can have a negative impact on mining and stabilizing the crown of the full-sized tunnel.

b. The detailed geology of exploratory tunnels, regardless of their purpose, should be mapped in accordance with the procedures outlined in Appendix C. The cost of obtaining an accurate and reliable geologic map of a tunnel is insignificant compared to the cost of the tunnel and support system. The geologic information gained from such mapping provides a very useful dimension to interpretations of rock structure deduced from exposures in surface outcrops. A complete picture of the site geology can be achieved only if the geologic data and interpretations from surface mapping, borings, and pilot tunnels are combined and well correlated. Such analyses are best carried out using a GIS.

6-5. Test Fills and Trial Embankments

a. Test fills. Test fills are generally recommended where unusual soils or rockfill materials are to be compacted or if newly developed and unproven compaction equipment is to be employed. Test fills are valuable for training earthwork inspectors on large projects, especially if materials vary widely or if compaction control procedures are complex. Test fills constructed solely to evaluate new or different compaction equipment are ordinarily performed by the contractor at his expense. Rock test fills are most frequently required to determine optimum placement and compaction operations. Test quarries are often

associated with a rock test fill program to determine blasting requirements and to establish any required preplacement material processing. Test fills must be constructed ahead of contract advertisement as they are necessary to establish specifications. It is most economical if such test fills can be located in low stressed regions of the embankment and incorporated within the final embankment section. If cofferdams of compacted fill are required on the project, these can be utilized as test fills but only if their serviceability is not affected. In the past, COE Districts have found it most satisfactory to construct precontract test fills themselves by renting the necessary equipment or even letting a separate contract. The following two considerations are most important in execution of a test fill program:

(1) Plan of tests. Usually several different parameters are to be evaluated from a test fill program. Therefore, the test program should be thoroughly planned so that each parameter is properly isolated for evaluation. All aspects of the program must be treated in detail, particularly the means of measurements and controls and data reduction.

(2) Representative materials and procedures. The test fill operations must be representative with regard to prototype materials and placement and compaction procedures. This is especially critical in rock test fill programs associated with test quarries. For additional information, see EM 1110-2-1911 and Hammer and Torrey (1973).

b. Trial embankments. Trial embankments are infrequently used but may be the only reliable means for resolving uncertainties about the probable behavior of complex subsurface conditions or of poor quality embankment materials. For example, trial embankments were constructed at Laneport, TX (Parry 1976), Warm Springs, CA (Fagerburg, Price, and Howington 1989), and R. D. Bailey, WV Dams (Hite 1984).

(1) Where subsurface shear strengths are so low that the gain in strength from consolidation during construction must be relied upon, or if it is economical to do so, a trial embankment is desirable, especially where long embankments are to be constructed. A trial embankment affords the most reliable means for determining the field rate of consolidation and efficacy of methods to accelerate consolidation.

(2) Clay shale foundations are often jointed and slickensided and may contain continuous relict shear surfaces. Laboratory shear tests on undisturbed samples generally give too high shear strengths and may be badly misleading. The in situ mass strength of clay shales can best and frequently only be determined by analyzing existing slopes or constructing trial embankments. If trial embankments are incorporated within the final section, their height and slopes must be designed to result in desired shear stresses in the foundation. Where natural slopes are flat, suggesting that residual shear strengths govern stability of slopes and cuts, trial embankments can be useful in resolving uncertainties about available shear strengths; i.e., are natural slopes flat because residual shear strengths have developed or because of natural erosion processes and a mature landscape?

(3) If special circumstances indicate the desirability of using wet, soft clay borrow that cannot economically be reduced to conventional compaction water contents, a trial embankment should be strongly considered.

Section II
Test Grouting

6-6. Purpose

Test grouting operations are performed at projects where complex geological conditions or unusually severe project requirements make it necessary to acquire a knowledge of grouting performance prior to the letting of major contracts. Test grouting programs provide information necessary to formulate procedures and determine design specifications, costs, and appropriate equipment. Test grouting consists of performing experimental grouting operations on exploratory boreholes to determine the extent to which the subsurface materials are groutable. A well-conceived and well-conducted grout program can provide cost-effective data for the preparation of contract plans and specifications. This can reduce the potential for construction claims. Grouting procedures necessary for development of a satisfactory test grouting program are discussed in detail in TM 5-818-6, and EM 1110-2-3506.

6-7. Test Grouting Practices

In test grouting, the methods used should be guided by the geologic conditions at the site. For example, stage grouting is preferable in rock formations where joint permeability prevails and the weight of increasing overburden with depth tends to close and tighten joint passageways. In solutioned limestone formations or pervious lava flows, major water passageways may not decrease in size with depth. Consequently, stop grouting is preferable because this procedure is initially directed at the source of water seepage. Circle grouting is a more comprehensive test procedure. Multiple line grouting is also a comprehensive grout testing procedure but does not require as many grout holes as the circle grouting test.

6-8. Test Grouting Program

A test grouting program is nearly always performed in a small area. Where the ground water table is located in the limits of the curtain, it may be necessary to construct the grout curtains in closed circular or rectangular arrays. In this manner, the effectiveness of the grout curtain can be evaluated by performing pumping tests before and after grouting. The test well is usually located at the center of the grout curtain enclosure. Observation wells are positioned to radiate from one or more directions outward from the well and through the test curtain. Comparison of the reduction of water pumped from the well before and after grouting is a direct measure of the efficiency of the grout curtain. Where the water table is low or nonexistent, a multiple, linearly aligned curtain is sufficient for test purposes. Comparison of pre- and postgrouting pressure tests should be made to evaluate the effectiveness of the test grouting schemes. Some of the important variables a test grouting program should resolve are basic grouting methods, hole spacing, grout consistency and additives, and injection pressures. Some projects may require the testing and applicability of using chemical grout to solve difficult seepage or foundation competency problems.

6-9. Record Keeping

Meaningful evaluation of a grouting program is impossible without adequate record keeping. Variables that are pertinent in grouting are discussed in detail in TM 5-818-6 and EM 1110-1-3500 and will not be repeated here. They are numerous and unless the record keeping aspect of grouting is well-organized and given top priority, the value of the test grouting program will be lost. Records have traditionally been kept by hand on specially prepared forms. The Grouting Database Package (Vanadit-Ellis et al. 1995), a

PC-based, menu-driven program that stores and displays hole information, drilling activities, water pressure tests, and field grouting data is an improvement over manual record keeping methods and is available through USAEWES.

Section III
Piling Investigations

6-10. Piling Investigation Benefits

Piling investigations may be conducted prior to construction or, more commonly, as part of a construction project just prior to the start of production pile driving. Predicting the performance of driven piles has been extensively studied, and various methods, including some very sophisticated computer analyses, are available to the designer. While these are useful and adequate for predicting piling performance for small jobs, projects requiring large numbers of piles generally benefit from a preconstruction piling investigation. This is because the methods of analysis that are commonly used are conservative and may significantly underestimate the actual working capacity of pilings. In addition to providing reliable design load capacities, field tests can help answer questions such as: how much penetration into rock can be expected, what time-dependent effects can be expected, and do hard layers exist that will cause early refusal or make driving points a necessity? As in all aspects of geotechnical engineering, pile testing is subject to a margin of error which is dependent on the heterogeneity of the site being investigated. Where the site geology is very complex, the data from one pile load test will probably not be repeatable across the project site. In addition, the performance and efficiency of a pile driving hammer can vary tremendously, even for hammers with the same energy rating. Because the capacity of a pile is heavily influenced by the hammer, the results from a test program cannot be translated to the production piles on the final project without some reservations. All of these considerations aside, there are times when a pile testing program will result in a significant savings to a project or, at least, a high confidence level in the piles capacity. EM 1110-2-2906 provides detailed information of pile foundation design.

6-11. Driving Records

As with grouting, adequate evaluation of a pile driving job cannot be performed without adequate records. A sample form for recording pile driving data is shown in Figure 6-1. This form can be modified to meet particular designer's needs but generally lists the information that is of most interest.

6-12. Load Testing

The correct procedures for conducting a pile load test are given in numerous references including EM 1110-2-2906 and are not repeated here. Generally, a pile will be tested for axial load capacity, both in compression and tension, and for lateral resistance.

DAILY PILE RECORD FOR LARGE- AND SMALL-DIAMETER BORED PILES PILE RECORDS TO BE SUBMITTED TO OFFICE DAILY A SEPARATE SHEET TO BE USED FOR EACH PILE						
BLOCK NUMBER			DRAWING NUMBER / /			
1. General	Pile reference number		Pile diameter		Level of base	
			Underream diameter			
	Ground level		Cutoff level		Concreted level	
2. Drilling	Date started		Date completed			
	Error in position on plan					
3. Obstructions¹ Natural/ Unnatural	Type		Depth encountered		Penetration time	
	Type		Depth encountered		Penetration time	
4. Steel¹ main steel links or helix	Number of bars		Diameter		Length	
	Centers of bars/pitch		Diameter		Cover to all steel	
5. Concrete	Date started		Date completed		Concrete temperature	Quantity Actual: Theoretical:
	Mix		Slump		Supplier	
6. Borehole log and rock excavation	Depth of soil	Description of soil	Depth of rock	Description of rock	Depth of rock augered	Depth of rock chiseled
7. Casing¹	Depth of temporary casing		Depth of permanent casing		Reason for use of permanent casing	
8. Water¹	Depth encountered		Details of strong flow		Details of remedial measures	
	Depth to strong flow					
¹ If there are no changes to be recorded, items 3, 4, 7, and 8 need be completed for the first pile only in each block.						
Remarks: 						
Signed:			Site Contract Engineer:			

Figure 6-1. Example of a piling log. Modified from Tomlinson (1994)

Chapter 7 Laboratory Investigations

7-1. Purpose

The purpose of laboratory tests is to investigate the physical and hydrological properties of natural materials such as soil and rock, determine index values for identification and correlation by means of classification tests, and define the engineering properties in parameters usable for design of foundations. The engineering geologist and/or geotechnical engineer, using the test data and calling upon experience, can then accomplish safe and economical designs for engineering structures. Procedures to assure quality in laboratory testing are outlined in ER 1110-1-261 and -8100. This chapter is divided into four sections that discuss selection of testing methods and samples, index and classification tests, engineering properties of soil, engineering properties of rock, and engineering properties of shales and moisture-sensitive rocks. No attempt has been made to describe the techniques for performing individual tests; references are provided for that purpose. A wide range of soil and rock tests are identified, and the appropriate applications are discussed.

Section I

Test and Sample Selection

7-2. Needs for Test and Sample Selection

The selection of samples and the number and type of tests are largely influenced by local subsurface conditions and the size and type of structure. Table 7-1 lists references that provide guidance for assigning laboratory tests for various types of structures. As a minimum, all soil samples should be classified according to the USCS (paragraph 5-8), and moisture contents should be determined on cohesive soils and on unsaturated granular soils that have 12 percent or more fines. Rock cores should be visually classified and logged prior to laboratory testing. The geologic model (paragraph 3-1) can be further developed using the results of basic indexing of soils and rock cores, together with other geotechnical data obtained from field reconnaissance and preliminary investigations. The geologic model, in the form of profiles and sections, can be used to indicate where additional indexing of soils and rock is needed, as well as the type and number of tests required to determine the engineering properties of all materials influencing the project. As more data become available, the testing requirements should be reviewed and modified as necessary.

a. Selection of samples for testing. Most index testing of soil and rock is performed on disturbed samples, i.e., samples that have not had special handling to preserve structural integrity. However, to determine natural water content the sample must be protected from drying. For soils, protection can be accomplished by using sealed metal tubes or plastic or glass jars. For rock, samples are normally waxed to prevent drying. Because many laboratory tests, particularly those to determine engineering properties, require "undisturbed" samples, great care must be exercised in storing, selecting, shipping, and preparing these materials. The geologist and/or geotechnical engineer responsible for applying test data to project requirements should have positive control of sampling and shipping of soil and rock samples. Table 7-2 lists some of the factors that may cause undisturbed samples to be less representative of the conditions encountered on the project.

b. Distribution and size of samples. The distribution of locations of soil and rock tests should be evaluated periodically. Within the project requirements, a suitable suite of index and engineering

Table 7-1
Guidance for Assigning Laboratory Tests

Type of Structure or Work	Reference
Embankment dams	EM 1110-2-2300 EM 1110-2-1902
Concrete gravity dams	EM 1110-2-2300 EM 1110-2-1902
Buildings and other structures	TM 5-818-1
Deep excavations	TM 5-818-5/AFM 88-5, Chapter 6/NAVFAC P-418
Tunnels and shafts in rocks	EM 1110-2-2901
Breakwaters	EM 1110-2-2904
Pile structures and foundations	EM 1110-2-2906
Levees	EM 1110-2-1913

Table 7-2
Factors Causing Undisturbed Samples to be Less Representative of Subsurface Materials

Factor	Effect on	
	Soils	Rocks
Physical disturbance from sampling and transportation	<p>Effect on shear strength:</p> <ul style="list-style-type: none"> a. Reduces Q and UC strength. b. Increases R strength. c. Little effect on S strength. d. Decreases cyclic shear resistance. <p>Effect on consolidation test results:</p> <ul style="list-style-type: none"> a. Reduces P b. Reduces C_c^* c. Reduces c_v in vicinity of σ_p and at lower stresses. d. Reduces C_{α}. 	<p>Cause breaks in core; may be difficult to obtain intact specimens suitable for testing</p> <p>May seriously affect weakly cemented materials, e.g., for sandstones, may destroy evidence of significant cementation. Foundation may appear to be more fractured than it is</p> <p>May prevent testing of some materials</p> <p>May reduce deformation modulus, E</p>
Changed stress conditions from in situ to ground surface locations	Similar to physical disturbance but less severe	Stress relief may cause physical disturbance similar to that from sampling and transportation. Deformation modulus reduces with decreasing stress field
Contamination of sands from drilling mud	Greatly reduces permeability of undisturbed samples	

Note: Q = Unconsolidated-undrained triaxial test; UC = Unconfined compression test; σ_p = Preconsolidation pressure; C_c = Compression index; c_v = Coefficient of consolidation; C_{α} = Coefficient of secondary compression; R = Consolidation-undrained triaxial test; S = Drained direct shear test.

property tests should be planned both in the vertical as well as lateral direction. Duplication of costly, complex tests should be avoided except where statistical balance is required. If it becomes apparent in the application of the test data that coverage of field conditions is irregular, or missing in certain stratigraphic units, field sampling procedures should be revised. Undisturbed sample sizes for soils should conform to those given in Appendix F. Rock sample sizes can range from 4.763 to 20 cm (1.875 to 6.0 in.). Large-diameter cores are obtained in lieu of the smaller core sizes in cases where rock defects make core recovery and sample quality difficult to attain. In some cases, the test procedure may dictate sample size. Rock tests and procedures are presented in the Rock Testing Handbook (USAEWES 1993).

Section II

Index and Classification Tests

7-3. Soils

Types of index and classification tests that are typically required are listed in Table 7-3 together with their reporting requirements. Initially, disturbed samples of soils are classified according to the USCS. Upon visual verification of the samples, Atterberg limits, mechanical analyses, and moisture content tests will be performed (Schroeder 1984; Gillott 1987). Table 7-3 also presents two other index tests relating to durability under cyclic weather conditions (slaking tests), and shear strength (torvane and penetrometer). The torvane and penetrometer shear tests are simple and relatively inexpensive; however, the test results can be widely variable and should be used with caution. These shear tests can be helpful as a guide to more comprehensive tests. Slaking tests are valuable if the project is located in moisture sensitive clays and clay shales, and foundation design requirements indicate that the foundation and cut slope areas will be exposed temporarily to wetting and drying conditions.

Table 7-3
Index and Classification Tests for Soils

Test	Remarks
Water content ¹	Required for every sample except clean sands and gravels
Liquid limit and plastic limit ¹	Required for every stratum of cohesive material; always have associated natural water content of material tested (compute liquidity index) ²
Sieve	Generally performed on silts, sands, and gravels (> 200 mesh)
Hydrometer analysis	Generally performed on soils finer than the No. 10 sieve size (medium sand and finer). Correlate with Atterberg limit tests to determine the plasticity of the soil
Slaking test	Performed on highly preconsolidated clays and clay shales where deep excavations are to be made or foundations will be near-surface. Wet and dry cycles should be used
Pocket penetrometer and torvane	Performed on cohesive materials, undisturbed samples, and intact chunks or disturbed samples. Regard results with caution; use mainly for consistency classification and as guide for assigning shear tests
X-ray diffraction	Generally performed on clays and clay shales to determine clay mineralogy which is a principal indicator of soil properties

¹ See EM 1110-2-1906 for procedures.

² Liquidity index = $LI = \frac{w_n - PL}{LL - PL}$. (w_n =natural water content).

7-4. Rock

All rock cores will be logged in the field and the log verified by the project geologist or geotechnical engineer prior to selection of samples for index and classification tests. Types of index and classification tests which are frequently used for rock are listed in Table 7-4. Water content, unit weight, total porosity, and unconfined (uniaxial) compression tests will be performed on representative cores from each major lithological unit to characterize the range of properties. The RQD values (TM 5-818-1), as developed by Deere (1964), may be assigned to rock cores as a guide prior to testing. Additional tests for bulk specific gravity, apparent specific gravity, absorption, elastic constants, pulse velocity, and permeability, as well as a petrographic examination, may be dictated by the nature of the samples or by the project requirements (Das 1994). Samples of riprap and aggregate materials will be tested for durability and resistance to abrasion, and the specific gravity of the solids should be determined. Data from laboratory index tests and core quality conditions may be used for rock classification systems such as those developed by Bieniawski (1979) and Barton, Lien, and Lunde (1974).

Table 7-4
Laboratory Classification and Index Tests for Rock

Test	Test Method	Remarks
Unconfined (uniaxial) compression	RTH 111 ¹	Primary index test for strength and deformability of intact rock
Specific gravity of solids	RTH 108 ¹	Indirect indication of soundness of rock intended for use as riprap and drainage aggregate
Water content	RTH 106 ¹	Indirect indication of porosity of rock or clay content of sedimentary rock
Pulse velocities and elastic constants	RTH 110 ¹	Index of compressional wave velocity and ultrasonic elastic constants for correlation with in situ geophysical test results
Rebound number	RTH 105 ¹	Index of relative hardness of intact rock cores
Permeability	RTH 114 ¹	Intact rock (no joints or major defects)
Petrographic examination	RTH 102 ¹	Performed on representative cores of each significant lithologic unit
Specific gravity and absorption	RTH 107 ¹	Indirect indication of soundness and deformability
Unit weight and total porosity	RTH 109 ¹	Indirect indication of weathering and soundness
Durability	TM 5-818-1, Federal Highway Administration (1978) Morgenstern and Eigenbrod (1974)	Index of weatherability of rock exposed in excavations and durability of rock for rockfill and riprap
Resistance to abrasion	RTH 115 ¹	Los Angeles abrasion test; limited usefulness for evaluating weatherability of riprap
Point load testing	RTH 325 ¹	May be used to predict other strength parameters with which it is correlated

¹ Rock Testing Handbook (USAEWES 1993).

Section III
Engineering Property Tests - Soils

7-5. Background

Reference should be made to EM 1110-2-1906 for current soil testing procedures and EM 1110-1-1904 for methods of settlement analysis.

a. Shear strength. Shear strength values are generally based on laboratory tests performed under three conditions of test specimen drainage. Tests corresponding to these drainage conditions are: unconsolidated-undrained Q tests in which the water content is kept constant during the test; consolidated-undrained R tests in which consolidation or swelling is allowed under initial stress conditions, but the water content is kept constant during application of shearing stresses; and consolidated-drained S tests in which full consolidation or swelling is permitted under the initial stress conditions and also for each increment of loading during shear. The appropriate Q, R, and S tests should be selected to reflect the various prototype loading cases and drainage conditions. Normally, strength tests will be made with the triaxial compression apparatus except S tests on fine-grained (relatively impervious) soils, which generally are tested with the direct shear apparatus because of time constraints using the triaxial apparatus. Where impervious soils contain significant quantities of gravel sizes, S tests should be performed on triaxial compression apparatus using large-diameter specimens.

(1) Q test. The shear strength resulting from a Q test corresponds to a constant water content condition, which means that a water content change is not permitted prior to or during shear. The Q test conditions approximate the shear strength for short-term conditions, e.g., the end-of-construction case. In cases where a foundation soil exists that is unsaturated but will become saturated during construction, it is advisable to saturate undisturbed specimens prior to axial loading in the Q test.

(2) R test. The shear strength resulting from an R test is obtained by inducing complete saturation in specimens using backpressure methods, consolidating these specimens under confining stresses that bracket estimated field conditions, and then shearing the specimens at constant water content. The R test applies to conditions in which impervious or semipervious soils that have been fully consolidated under one set of stresses are subject to a stress change without time for consolidation to take place.

(3) S test. The shear strength resulting from an S test is obtained by consolidating a sample under an initial confining stress and applying shear stresses slowly enough to permit excess pore water pressures to dissipate under each loading increment. Results of S tests are applicable to free-draining soils in which pore pressures do not develop. In cohesive soils, S tests are used for evaluating the shear strength of long-term conditions, e.g., "normal operating" case. The R-bar test, a consolidated, undrained triaxial test in which pore pressures are measured during shear to determine the effective stress, has sometimes been used by a USACE district in lieu of the S test.

(4) Selection of design shear strengths. When selecting design shear strengths, the shape of the stress-strain curves for individual soil tests should be considered. Where undisturbed foundation soils and compacted soils do not show a significant drop in shear or deviator stress after peak stresses are reached, the design shear strength can be chosen as the peak shear stress in S direct shear tests, the peak deviator stress, or the deviator stress at 15 percent strain where the shear resistance increases with strain. For each soil layer, design shear strengths should be selected such that two-thirds of the test values exceed the assigned design values.

b. *Permeability.* To evaluate seepage conditions, reasonable estimates of permeability of pervious soils are required. Field pumping tests (TM 5-818-5) or correlations between a grain-sized parameter (such as D_{10}) and the coefficient of permeability, as in Figure 3-5, EM 1110-2-1913, are generally used for coarse-grained materials below the water table. The permeability of compacted cohesive soils for embankments and backfills and for soils modified in place is generally estimated from consolidation tests. Laboratory permeability tests are also being used more frequently for these materials.

c. *Consolidation and swell.* The parameters required to perform settlement and rebound analyses are obtained from consolidation tests on highly compressible clays or on compressible soils subjected to high stresses. Swell tests are also performed to identify, confirm, and quantify swelling ground conditions in tunneling. The sequence and magnitude of test loading should approximate the various prototype loading cases for which settlement and rebound analysis are to be performed. For expansive soils, the standard consolidation test or a modification of the test (Johnson, Sherman, and Al-Hussaini 1979) may be used to estimate both swell and settlement. Consolidometer swell tests tend to predict minimal levels of heave. Soil suction tests (Johnson, Sherman, and Al-Hussaini 1979) can be used to estimate swell. However, this test tends to overestimate heave compared with field observations. Gillott (1987) describes various tests to evaluate expansive soils.

Section IV
Engineering Property Tests - Rock

7-6. Background

Table 7-5 lists the laboratory tests frequently performed to determine the engineering properties of rock. These and other rock tests are presented in the Rock Testing Handbook (USAEWES 1993) and Nicholson (1983b).

Table 7-5
Laboratory Tests for Engineering Properties of Rock

Test	Reference	Remarks
Elastic moduli from uniaxial compression test	RTH 201 ¹	Intact rock cores
Triaxial compressive strength	RTH 202 ¹	Deformation and shear strength of core containing inclined joints
Direct shear strength	RTH 203 ¹	Strength along planes of weakness (joints) or rock-concrete contact
Creep in compression	RTH 205 ¹	Intact rock from foundation where time-dependent compression is an important factor in design
Thermal diffusivity	RTH 207 ¹	Intact rock subjected to elevated temperatures such as adjacent to mass concrete where heat conductance is a factor

¹ Rock Testing Handbook (USAEWES 1993).

a. *Unconfined uniaxial compression test.* The unconfined uniaxial compression test is performed primarily to obtain the elastic modulus and unconfined compressive strength of a rock sample. Poisson's ratio can be determined if longitudinal and lateral strain measurements are made on the sample during the test. The value of Poisson's ratio is required for describing the deformation characteristics of a rock mass. Occasionally, design requirements dictate the need for testing of samples at different orientations

to describe 3-D anisotropy. This test is economical, adequate for most foundation testing, and therefore a useful test for smaller projects. See USAEWES (1993), methods RTH 201-89 (ASTM D 3148-86 (ASTM 1996g)) and RTH 205-93 (ASTM D 4405-84 (ASTM 1996i)) for standard test methods.

b. Point load tests. Although the point load test is, strictly speaking, an index test for rock, it can be equated with the unconfined uniaxial compression strength. Its advantage lies in the ease with which the test can be conducted. The testing apparatus is portable so that it can be used in the field to test cores as they are retrieved from the ground. In this way, a statistically significant amount of data can be collected economically and with minimal effects from aging and handling of the cores. In addition, the tests can be run both perpendicular and parallel to the axis on the same piece of core, cut block, or irregular lump to provide a measure of the anisotropy of the rock strength. RTH 325-89 (USAEWES 1993) presents the suggested method for conducting point load strength tests.

c. Tensile strength. The tensile strength of rock is normally determined by the Brazilian method (RTH 113-93 (USAEWES 1993)) in which a piece of core is split along its axis. In some cases, direct pull tensile tests are conducted, but these samples are much harder to prepare. Results of the tensile strength tests provide input that can be used in the design of underground openings.

d. Unit weight. Determination of the unit weight of the various lithologies at a site is an important piece of engineering data. It is used for input into blast performance and muck handling, among other things. Since the unit weight is a nondestructive test, the sample can be subjected to additional tests after the unit weight is determined.

e. Direct shear test. Laboratory triaxial and direct shear tests on intact rock cores and intact rock cores containing recognizable thin, weak planes are performed to determine approximate values of cohesion, c (shear strength intercept) and ϕ (angle of internal friction) of a rock type. Detailed procedures for making the laboratory direct shear test are presented in RTH 203-80 (USAEWES 1993). The test is performed on core samples ranging from 6.5 to 20 cm (2 to 6 in.) in diameter. The samples are trimmed to fit into a shear box or machine and oriented so that the normally applied force is perpendicular to the feature being tested. Results of tests on intact samples will give upper-bound strength values while tests on smooth surfaces give lower-bound values. Repetition of the shearing process on a sample, or continuing, displacement to a point where shear strength becomes constant can ultimately establish the residual shear strength value. Where natural discontinuities control the rock mass shear strength, tests should be performed to determine the friction angle of the discontinuity asperities as well as the smooth discontinuity plane. The direct shear test is not suited to the development of exact stress-strain relationships because of the nonuniform distribution of shearing stresses and displacements within the test specimen. The bonding strength of a rock/concrete contact can be determined by this test. Values of cohesion and angles of internal friction are used to determine strength parameters of foundation rock. These values are the principal parameters in the analytical procedures to define the factor of safety for sliding stability and for some bearing capacity analysis. They are appropriate in analyses of the stability of rock slopes and of structures subjected to nonvertical external loading. For the test results to have valid application, test conditions must be as close as possible to actual field conditions. This includes selection of the normal loads to be used. Since the failure envelope is nonlinear at the lower load ranges, testing performed with too little or too much normal load will not adequately model actual conditions and will yield inappropriate values of c and ϕ . The application of these values is discussed in detail in Corps of Engineers guidance on gravity dam design (EM 1110-1-2908), and in Ziegler (1972) and Nicholson (1983a).

f. Triaxial shear test. The triaxial shear test can be made on intact, cylindrical rock samples. The test provides the data for determination of rock strength in an undrained state under 3-D loading. Data from the test can provide, by calculation, the strength and elastic properties of the rock samples at various confining pressures, the angle of internal friction (shearing resistance), the cohesion intercept, and the deformation modulus. Strength values are in terms of total stress as pore water pressure is not measured, and corrections should be made accordingly. The standard test method is presented as RTH 202-89 (USAEWES 1993) (ASTM D 2664-86 (ASTM 1996f)). A variation of this test using multistage triaxial loading (RTH 204-80 (USAEWES 1993)) is sometimes used to evaluate the strength of joints, seams, and bedding planes at various confining pressures.

g. Other testing. There are numerous other engineering properties (e.g., toughness, abrasiveness) of rock that are of interest in different applications and all have different testing procedures. The designer is advised to search the literature, including the RTH, to determine which testing is appropriate.

Section V

Engineering Property Tests - Shales and Moisture-Sensitive Rocks

7-7. Index Testing

Most moisture-sensitive geomaterials are sedimentary or metamorphic in origin. These include clays, clay shales, poorly to moderately cemented sandstones, marl, and anhydrite. Most commonly, moisture-sensitive rock and sediment contain clay minerals, particularly smectites, which have the capacity to hold large volumes of interstitial water. In some cases, the weathered product of a rock type may be the sensitive material in the overall rock mass and can be the result of chemical weathering (saprolite) or rock movement (fault gouge, mylonite). As these rock forms have soil-like characteristics, the index properties (Atterberg limits, moisture content, etc.) of these materials should be determined prior to more comprehensive testing. The results of the index testing usually indicate the engineering sensitivity of the rock forms and should be used as a guide to further testing. Special procedures that may be necessary for index testing can be found in EM 1110-2-1906.

a. Direct and triaxial shear tests. Most direct and triaxial shear tests conducted on hard, brittle rock samples are of the undrained type. For these particular types of materials, pore pressures do not play a dominant role, and strength values are in terms of total stress. However, as softer rock types are encountered, with correspondingly higher absorption values (e.g., greater than 5 percent), the role of pore pressure buildup during the rock shearing process becomes more important. The same condition is true for many clay shales and other similar weak and weathered rock materials. For moisture-sensitive rocks, soil property test procedures should be used if possible. Critical pore pressures that may substantially reduce the net rock strength can then be monitored throughout the entire testing cycle. Where hydraulic concrete structures are to be constructed on clay shales or shales, shear testing should be conducted to determine the strength of the shale/concrete interface.

b. Test data interpretation. Laboratory test data on shales and moisture-sensitive rocks should be interpreted with caution. The laboratory undrained strength of intact specimens is rarely representative of in-place field shear strengths. Frequently, shales, clay shales, and highly overconsolidated clays are reduced to their residual shear strength with minor displacements. The geotechnical explorations, laboratory testing, and review of field experiences must establish whether residual or higher shear strengths are appropriate for design purposes. Results of laboratory tests should be confirmed by analysis of the field behavior of the material from prior construction experience in the area, analysis of existing slopes or structures, and correlation with similar geologic formations at sites where the field

performance is known. For a general engineering evaluation of the behavioral characteristics of shales, see Table 3-7, TM 5-818-1, Underwood (1967), and Townsend and Gilbert (1974); for physical properties of various shale formations, see Table 3-8, TM 5-818-1. Slope stability of shales can be analyzed using the PC-based, menu-driven program, UTEXAS3 (Edris 1993), ROCKPACK (Watts 1996) or the International Forum on Discontinuous Deformation Analysis Method (International Forum on Discontinuous Deformation Analysis and Simulations or Discontinuing Media 1996).

7-8. Swelling Properties

For many shales and moisture-sensitive rocks, swelling characteristics are a key consideration. Where used as fill, their physical properties can change significantly over time, and in response to the presence of water (Nelson and Miller 1992). In addition, swelling of in situ rock has caused heave in foundations, slope failures, distress in slope treatments such as shotcrete, and failure of tunnel linings (Olivier 1979). EM 1110-1-2908 has a thorough discussion of the testing procedures used to evaluate swelling potential of rock and soil. For the constant volume test, great care should be exercised in interpreting the results. The procedure currently in use calls for increasing applied load periodically during the test to return the specimen to its original dimensions. This load may exceed the actual swell pressure because it also must overcome the elastic properties of the rock.

Appendix A References

A-1. Required Publications

TM 5-818-1/AFM 88-3, Chapter 7

Procedures for Foundation Design of Buildings and Other Structures

TM 5-818-5/AFM 88-5, Chapter 6, NAVFAC P-418

Dewatering and Groundwater Control

TM 5-818-6

Grouting Methods and Equipment

TM 5-858-3

Designing Facilities to Resist Nuclear Weapons Effects: Structures

MIL-STD 621A

Test Methods for Pavement Subgrade, Subbase, and Base Course Material

ER 415-1-11

Biddability, Constructibility, Operability, and Embankment Review

ER 415-2-100

Staffing for Civil Works Projects

ER 715-1-13

Procurement of Diamond Drill Bits and Reaming Shells

ER 1105-2-100

Planning Guidance Notebook

ER 1110-1-5

Plant Pest Quarantined Areas and Foreign Soil Samples

ER 1110-1-261

Quality Assurance of Laboratory Testing Procedures

ER 1110-1-1807

Procedures for Drilling in Earth Embankments

ER 1110-1-8100

Laboratory Investigations and Testing

ER 1110-2-1150

Engineering and Design for Civil Works Projects

EM 1110-1-1804
1 Jan 01

ER 1110-2-1200
Plans and Specifications for Civil Works Projects

ER 1110-2-1806
Earthquake Design and Evaluation of Civil Works Projects

ER 1110-2-1925
Field Control Data for Earth and Rockfill Dams

ER 1110-3-110
Information Systems Design in Support of Military Construction

ER 1180-1-6
Construction Quality Management

EP 1110-1-10
Borehole Viewing Systems

EM 200-1-3
Requirements for the Preparation of Sampling and Analysis Plans

EM 1110-1-1000
Photogrammetric Mapping

EM 1110-1-1002
Survey Markers and Monumentation

EM 1110-1-1003
NAVSTAR Global Positioning System Surveying

EM 1110-1-1005
Topographic Surveying

EM 1110-1-1802
Geophysical Exploration for Engineering and Environmental Investigations

EM 1110-1-1904
Settlement Analysis

EM 1110-1-1906
Soil Sampling.

EM 1110-1-2908
Rock Foundations

EM 1110-1-3500
Chemical Grouting

EM 1110-1-4000

Monitor Well Design, Installation, and Documentation at Hazardous and/or Toxic Waste Sites

EM 1110-2-1003

Hydrographic Surveying

EM 1110-2-1202

Environmental Engineering for Deep-draft Navigation Projects

EM 1110-2-1204

Environmental Engineering for Coastal Protection

EM 1110-2-1205

Environmental Engineering and Local Flood Control Channels

EM 1110-2-1206

Environmental Engineering for Small Boat Basins

EM 1110-2-1418

Channel Stability Assessment for Flood Control Projects

EM 1110-2-1901

Seepage Analysis and Control for Dams

EM 1110-2-1902

Stability of Earth and Rockfill Dams

EM 1110-2-1906

Laboratory Soils Testing

EM 1110-2-1908

Instrumentation of Embankment Dams and Levees

EM 1110-2-1911

Construction Control for Earth and Rockfill Dams

EM 1110-2-1913

Design and Construction of Levees

EM 1110-2-2300

Earth and Rockfill Dams, General Design and Construction Considerations

EM 1110-2-2301

Test Quarries and Test Fills

EM 1110-2-2901

Tunnels and Shafts in Rock

EM 1110-1-1804
1 Jan 01

EM 1110-2-2904
Design of Breakwaters and Jetties

EM 1110-2-2906
Design of Pile Foundations

EM 1110-2-3506
Grouting Technology

EM 1110-2-3800
Systematic Drilling and Blasting for Surface Excavations

EM 1110-2-4000
Sedimentation Investigations of Rivers and Reservoirs

American Society for Testing and Materials 1970
American Society for Testing and Materials. 1970. "Special Procedures for Testing Soil and Rock for Engineering Purposes," STP 479, 5th ed., Philadelphia, PA.

American Society for Testing and Materials 1996a
American Society for Testing and Materials. 1996a. "Bearing Capacity of Soil for Static Load on Spread Footings, Designation D-1194-94," West Conshohocken, PA.

American Society for Testing and Materials 1996b
American Society for Testing and Materials. 1996b. "Method for Penetration Test and Split-Barrel Sampling of Soils, Designation D 1586-84," West Conshohocken, PA.

American Society for Testing and Materials 1996c
American Society for Testing and Materials. 1996c. "Standard Practice for Thin-Walled Tube Geotechnical Sampling of Soils, Designation: D 1587-94," West Conshohocken, PA.

American Society for Testing and Materials 1996d
American Society for Testing and Materials. 1996d. "Description and Identification of Soils (Visual-Manual Procedure), Designation D 2488-93," West Conshohocken, PA.

American Society for Testing and Materials 1996e
American Society for Testing and Materials. 1996e. "Test Method for Field Vane Shear Test in Cohesive Soil, Designation D 2573-94," West Conshohocken, PA.

American Society for Testing and Materials 1996f
American Society for Testing and Materials. 1996f. "Test Method for Triaxial Compressive Strength of Undrained Rock Core Specimens Without Pore Pressure Measurements, Designation D 2664-86," West Conshohocken, PA.

American Society for Testing and Materials 1996g
American Society for Testing and Materials. 1996g. "Test Method for Elastic Moduli of Intact Rock Core Specimens in Uniaxial Compression, Designation D 3148-93," West Conshohocken, PA.

American Society for Testing and Materials 1996h

American Society for Testing and Materials. 1996h. "Standard Test Method for One-dimensional Expansion, Shrinkage, and Uplift Pressure of Soil-Lime Mixtures, Designation D 3877-80," West Conshohocken, PA.

American Society for Testing and Materials 1996i

American Society for Testing and Materials. 1996i. "Test Method for Creep of Cylindrical Soft Rock Core Specimens in Uniaxial Compression, Designation D 4405-93," West Conshohocken, PA.

American Society for Testing and Materials 1996j

American Society for Testing and Materials. 1996j. "Standard Test Method for In Situ Stress and Modulus of Deformation Using the Flatjack Method, Designation D 4729-87," West Conshohocken, PA.

Borrelli 1988

Borrelli, D. D. 1988. "Interim Guidance for Construction Site Clearance at U.S. Army Installations," U.S. Army Toxic and Hazardous Materials Agency, Aberdeen Proving Ground, Maryland.

U.S. Army Engineer Waterways Experiment Station 1993

U.S. Army Engineer Waterways Experiment Station. 1993. *Rock Testing Handbook*. Technical Information Center, Vicksburg, MS 39180.

Walker 1988

Walker, L. D. 1988. Memorandum: "Environmental Survey Guidance for Potential Construction Sites," U.S. Army Engineering and Construction Division, Washington, DC.

A-2. Related Publications

Al-Khafaji and Andersland 1992

Al-Khafaji, A. W., and Andersland, O. B. 1992. *Geotechnical Engineering and Soil Testing*, Saunders College Publishing, Harcourt Brace Jovanovich College Publishers, Fort Worth, TX.

Aller et al. 1989

Aller, L., Bennett, T., Hackett, G., Petty, R., Lehr, J., Sedoris, H., Nielsen, D., and Denne, J. 1989. *Handbook of Suggested Practices for the Design and Installation of Ground-Water Monitoring Wells*, prepared for the Environmental Monitoring Systems Laboratory Office of Research and Development, U.S. Environmental Protection Agency, Las Vegas, NV. Published by National Water Well Association, Dublin, OH.

Annan 1992

Annan, A. P. 1992. Ground Penetrating Radar Workshop Notes. Sensing & Software Inc., Mississauga Ontario, Canada.

Applied Technology Council 1978

Applied Technology Council. 1978. "Tentative provision for the development of seismic regulations for buildings," Figure 1-1, Publication ATC3-06, National Bureau of Standards 510, National Science Foundation 78-8, Washington, DC.

EM 1110-1-1804
1 Jan 01

Baguelin, Jezequel, and Shields 1978

Baguelin, F., Jezequel, J. F., and Shields, D. H. 1978. "The Pressuremeter and Foundation Engineering," Trans Tech Publications, Rockport, MA.

Barton, Lien, and Lunde 1974

Barton, N., Lien, R., and Lunde, J. 1974. "Engineering Classification of Rock Masses for the Design of Tunnel Support," *Rock Mechanics*, Vol 6, No. 4, pp 183-236.

Bechtell 1975

Bechtell, W. R. 1975. "Project R. D. Bailey Experimental Excavation Program," U.S. Army Engineer Waterways Experiment Station, Technical Report E-73-2, Vicksburg, MS.

Bennett and Anderson 1982

Bennett, R. D., and Anderson, R. F. 1982. "New Pressure Test for Determining Coefficient of Permeability of Rock Masses," Technical Report GL-82-3, U.S. Army Engineer Waterways Experiment Station, Vicksburg, MS.

Bentall 1963

Bentall, R. 1963. "Shortcuts and Special Problems in Aquifer Tests," Geological Survey Water-Supply Paper 1545-C, a collection of reports, U.S. Geological Survey, U.S. Government Printing Office, Washington, DC.

Bertram 1979

Bertram, G. E. 1979. "Field Tests for Compacted Rockfill," *Embankment Dam Engineering*, R. C. Hirschfield and S. J. Poulos, Editors, Wiley-Interscience, Somerset, NJ.

Bieniawski 1979

Bieniawski, Z. T. 1979. "Tunnel Design by Rock Mass Classification," Technical Report GL-79-19, U.S. Army Engineer Waterways Experiment Station, Vicksburg, MS.

Blight 1974

Blight, G. E. 1974. "Indirect Determination of In Situ Stress Ratios in Particulate Materials," Proceedings of a Speciality Conference, *Subsurface Exploration for Underground Excavation and Heavy Construction*, American Society of Civil Engineers, New York, NY.

Bjerrum 1972

Bjerrum, L. 1972. "Embankments on Soft Ground," Proceedings of Speciality Conference, *Performance of Earth and Earth-Supported Structures*, Vol II, pp 1-54, American Society of Civil Engineers, New York, NY.

Boadu and Long 1994

Boadu, F. K., and Long, L. T. 1994. "The Fractal Character of Fracture Spacing and RQD," *International Journal of Rock Mechanics, Mining Science, and Geomechanics*, Vol 31, No. 2, pp 127-134.

Bowles 1996

Bowles, J. E. 1996. *Foundation Analysis and Design*, 5th ed., McGraw-Hill, New York, NY.

Burrough 1986

Burrough, P. A. 1986. "Principles of Geographic Information Systems for Land Resource Assessment," Monographs on Soils and Resources Survey No. 12, Oxford University Press, New York, NY.

Butler 1980

Butler, D. K. 1980. "Microgravimetric Techniques for Geotechnical Applications," Miscellaneous Paper GL-80-13, U.S. Army Engineer Waterways Experiment Station, Vicksburg, MS.

Cernica 1993

Cernica, J. N. 1993. *Geotechnical Engineering: Soil Mechanics*, John Wiley & Sons, New York, NY.

Cottin et al. 1986

Cottin, J. F., Deletie, P., Jacquet-Francillon, H., Lakshmanan, J., Lemoine, Y., and Sanchez, M. 1986. "Curved ray seismic tomography: Application to Grand Etang Dam (Reunion Island)," *First Break* vol 4 pp 25-30.

Das 1994

Das, B. M. 1994. *Principles of Geotechnical Engineering*, 3rd ed., PWS Publishing, Boston, MA.

Davis and DeWiest 1966

Davis, S. N., and DeWiest, R. J. M. 1966. *Hydrogeology*, John Wiley & Sons, New York, NY.

Dawson and Istok 1991

Dawson, K. J., and Istok, J. D. 1991. *Aquifer Testing, Design and Analysis of Pumping and Slug Tests*, Lewis Publishers, Inc., Chelsea, MI.

Dearman 1991

Dearman, W. R. 1991. *Engineering Geological Mapping*, Butterworth-Heinemann, Boston, MA.

Deere 1964

Deere, D. U. 1964. "Technical Description of Rock Cores for Engineering Purposes," *Rock Mechanics and Engineering Geology*, Vol 1, No. 1, pp 17-22.

Deere and Deere 1989

Deere, D. U., and Deere, D. W. 1989. "Rock Quality Designation (RQD) After Twenty Years." Contract Report GL-89-1, U. S. Army Engineer Waterways Experiment Station, Vicksburg, MS.

Deklotz and Boisen 1970

Deklotz, E. J. and Boisen, B. P. 1970. "Development of Equipment for Determining Deformation Modulus and In Situ Stress by Means of Large Flatjacks," *Determination of In Situ Modulus of Deformation of Rock*, ASTM STP 477, American Society for Testing and Materials, Philadelphia, PA.

Dodd, Fuller, and Clarke 1989

Dodd, K, Fuller, H. K., and Clarke, P. F. 1989. "Guide to Obtaining USGS Information," USGS Circular 900, U.S. Government Printing Office, Washington, DC.

EM 1110-1-1804
1 Jan 01

Douglas and Olsen 1981

Douglas, B. J., and Olsen, R. S. 1981. "Soil Classification Using the Electric Cone Penetrometer." *Proceedings of the Cone Penetration Testing and Experience Session, ASCE National Convention, St. Louis, Oct 1981, American Society of Civil Engineers, New York, NY.*

Driscoll 1986

Driscoll, F. G. 1986. *Groundwater and Wells, 2nd ed.*, Johnson Division, St.Paul, MN.

Durgunoglu and Mitchell 1975

Durgunoglu, H. T., and Mitchell, J. K. 1975. Static Penetration Resistance of Soils, Evaluation of Theory and Implication for Practice." *Proceedings of the In-situ Measurement of Soil Properties, Raleigh, NC, American Society of Civil Engineers, New York, NY.*

Edris 1993

Edris, E. V. 1993. User's Guide: UTEXAS3 Slope-Stability Package Volume III: Example Problems," Instruction Report GL-87-1, U.S. Army Engineer Waterways Experiment Station, Vicksburg, MS.

Eissa and Sen 1991

Eissa, E. A. and Sen, Z. 1991. "Fracture Simulation and Multi-Directional Rock Quality Designation." *Bulletin of The Association of Engineering Geologists, Vol 28, No. 2.*

Environmental Systems Research Institute 1992

Environmental Systems Research Institute. 1992. *Understanding GIS: The ARC/INFO® Method.* ESRI, Redlands, CA.

Fagerburg, Price, and Howington, 1989

Fagerburg, T. L., Price, R. E., and Howington, S. E. 1989. "Water Quality Outlet Works Prototype Tests, Warm Springs Dam, Dry Creek, Russian River Basin, Sonoma County, California," Technical Report HL-89-4, U.S. Army Engineers Waterways Experiment Station, Vicksburg, MS.

Federal Highway Administration 1978

Federal Highway Administration. 1978. "Design and Construction of Compacted Shale Embankments, Vol 5, Technical Guidelines," Report No. FHWA-RD-78-141, National Technical Information Service, Springfield, VA.

Fetter 1988

Fetter, C. W. 1988. *Applied Hydrogeology, Second Edition.* Macmillan Publishing, New York, NY.

Fisher and Banks 1979

Fisher, P. R., and Banks, D. C. 1979. "Influence of the Regional Geologic Setting on Site Geologic Features." *Site Characterization and Exploration, Proceedings, Speciality Workshop, Northwestern University, C. H. Dowding, ed., American Society of Civil Engineers, New York, NY.*

Franklin et al. 1981

Franklin, A. G., Patrick, D. M., Butler, D. K., Strohm, W. E., Jr., and Hynes-Griffin, M. E. 1981. "Foundation Considerations in Siting of Nuclear Facilities in Karst Terrains and Other Areas Susceptible to Ground Collapse," NUREG/CR-2062, U.S. Nuclear Regulatory Commission, Washington, DC.

Geological Society Engineering Group Working Party 1995

Geological Society Engineering Group Working Party. 1995. "The description and classification of weathered rocks for engineering purposes," *Quarterly Journal of Engineering Geology*, Vol 26 No. 3, pp 207-242.

Gillot 1987

Gillot, J. E. 1987. *Clay in Engineering Geology*. Elsevier, New York, NY.

Goodman 1976

Goodman, R. E. 1976. *Methods of Geological Engineering in Discontinuous Rock*. West Publishing Company, Saint Paul, MN.

Goodman 1981

Goodman, R. E. 1981. *Introduction to Rock Mechanics*. John Wiley & Sons, Sommerset, NY.

Goodman and Shi 1985

Goodman, R. E., and Shi, G. 1985. *Block theory and its application to rock engineering*. Prentice-Hall, Englewood Cliffs, NJ.

Gupta 1991

Gupta, R. P. M. 1991. *Remote Sensing Geology*. Springer-Verlag, New York, NY.

Hall, Newmark, and Hendron 1974

Hall, W. C., Newmark, N. M., and Hendron, A. J., Jr. 1974. "Classifying Engineering Properties and Field Exploration of Soils, Intact Rock and In Situ Rock Masses," Report No. WASH-1301, CU-II, U.S. Atomic Energy Commission, Washington, DC.

Hamison 1978

Hamison, B. C. 1978. "The Hydrofracturing Stress Measuring Method and Recent Field Results," *International Journal of Rock Mechanics and Mining Sciences*, Vol 15, No. 4, Pergamon Press, Elmsford, NY.

Hammer and Torrey 1973

Hammer, D. P., and Torrey, V. H. III. 1973. "Test Fills for Rockfill Dams," Miscellaneous Paper S-73-7, U.S. Army Engineer Waterways Experiment Station, Vicksburg, MS.

Harder and Seed 1986

Harder, L. F., Jr., and Seed, H. B. 1986. "Determination of Penetration Resistance for Coarse-Grained Soils Using the Becker Hammer Drill," Report No. UCB/EERC-86/06, Earthquake Engineering Research Center, College of Engineering, University of California, Berkeley.

Heath 1983

Heath, R. C. 1983. "Basic Ground-water Hydrology," U.S. Geological Survey Water-Supply Paper 2220, U.S. Government Printing Office, Washington, DC.

Hite 1984

Hite, S. E. 1984. "R.D. Bailey Outlet Works, Guyandot River, West Virginia: Hydraulic Model Investigation," Technical Report HL-84-1, U.S. Army Engineers Waterways Experiment Station, Vicksburg, MS.

EM 1110-1-1804
1 Jan 01

Hobbs, Means, and Williams 1986

Hobbs, B.E., Means, W.D., and Williams, P.F. 1976. *An Outline of Structural Geology*. John Wiley & Sons, New York, NY.

Hunt 1984

Hunt, R.E. 1984. *Geotechnical Engineering Investigation Manual*. McGraw-Hill, New York, NY.

Intergraph Corp. 1993

Intergraph Corp. 1993. *GIS Oriented Analysis Language (GOAL) User's Guide*. Huntsville, AL.

International Forum on Discontinuous Deformation Analysis and Simulations of Discontinuous Media 1996

International Forum on Discontinuous Deformation Analysis and Simulations of Discontinuous Media. 1996. "Discontinuous deformation analysis (DDA) and simulations of discontinuous media." *Proceedings of the First International Forum on Discontinuous Media, Berkeley, CA, USA, June 12-14, 1996*. Edited by M. Reza Salami and Don Banks.

Jamiolkowski et al. 1982

Jamiolkowski, M., Lancellotta, R., Tordella, L., and Battaglio, M. 1982. "Undrained Strength from CPT." *Proceedings of the Second European Symposium on Penetration Testing (ESOPT II)*, Amsterdam.

Johnson, Sherman, and Al-Hussaini 1979

Johnson, L. D., Sherman, W. C., Jr., and Al-Hussaini, M. M. 1979. "Overview for Design of Foundations on Expansive Soils," Miscellaneous Paper GL-79-21, U.S. Army Engineer Waterways Experiment Station, Vicksburg, MS.

Keller 1992

Keller, E. A. 1992. *Environmental Geology*. 6th ed., Macmillan, New York, NY.

Kilgore, Krolak, and Mistichelli 1993

Kilgore, R. T., Krolak, J. S., and Mistichelli, M. P. 1993. "Integration Opportunities for Computer Models, Methods, and GIS Used in Corps Planning Studies," IWR Report 93-R-5. U.S. Army Corps of Engineers Water Resources Support Center, Ft. Belvoir, VA.

Krinitzsky 1995

Krinitzsky, E. L. 1995. "State-of-the art for Assessing Earthquake Hazards in the United States, Report 29, Selection of Earthquake Ground Motions for Engineering," Miscellaneous Paper S-73-1, U.S. Army Engineer Waterways Experiment Station, Vicksburg, MS.

Krinitzsky 1996

Krinitzsky, E. L. 1996. Personal communication. U.S. Army Engineer Waterways Experiment Station, Vicksburg, MS.

Krinitzsky, Gould, and Edinger 1993

Krinitzsky, E. L., Gould, J. P., and Edinger, P. H. 1993. *Fundamentals of earthquake resistant construction*. John Wiley & Sons, New York, NY.

Lambe and Whitman 1969

Lambe, T. W., and Whitman, R. V. 1969. *Soil Mechanics*, Massachusetts Institute of Technology, John Wiley & Sons, New York, NY.

Larkin et al. 1990

Larkin, T. H., Johnson, P. A., Rich, P. M., Eischeid, G., and Phillips, W. S. 1990. "Cross-borehole compressional wave imaging of unconsolidated sediments," *IEEE Transactions on Geoscience and Remote Sensing*, Vol 28, pp 922-931.

Leach 1977

Leach, R. E. 1977. "Hydraulic Fracturing of Soils--a Literature Review," Miscellaneous Paper S-77-6, U.S. Army Engineer Waterways Experiment Station, Vicksburg, MS.

Lichy 1976

Lichy, D. E. 1976. "Remote Sensing Demonstration Project, Verona Lake Project, Virginia," U.S. Army Engineer District, Baltimore, MD.

Lohman 1972

Lohman, S. W. 1972. "Ground-Water Hydraulics," Geological Survey Professional Paper 708, U.S. Geological Survey, United States Government Printing Office, Washington, DC.

Lutton 1976

Lutton, R. J. 1976. "Review and Analysis of Blasting and Vibrations at Bankhead Lock," Technical Report S-76-6, U.S. Army Engineer Waterways Experiment Station, Vicksburg, MS.

Marcuson and Bieganousky 1977

Marcuson, W. F. III, and Bieganousky, W. A. 1977. "SPT and Relative Density in Coarse Sands," *Journal of the Geotechnical Engineering Division*, Vol 103, No. GT11, pp 1295-1309, American Society of Civil Engineers, New York, NY.

Means and Parcher 1963

Means, R. E., and Parcher, J. V. 1963. *Physical Properties of Soils*. Oklahoma State University, Charles E. Merrill Publishing Co., Columbus, OH.

Meyerhof 1956

Meyerhof, G. G. 1956. "Penetration Tests and Bearing Capacity of Cohesive Soils," *Journal, Soil Mechanics and Foundations Division*, Vol 82, No. SMI, pp 1-19, Also see closure in Vol 83, No. SMI, 1957, American Society of Civil Engineers, New York, NY.

Mitchell and Lunne 1978

Mitchell, J. K., and Lunne, T. A. 1978. "Cone Resistance as a Measure of Sand Strength." *Journal, Geotechnical Engineering Division*, Vol 104, No. GT7, pp 995-1012, American Society of Civil Engineers, New York, NY.

Mitchell and Villet 1981

Mitchell, J. K., and Villet, W. C. B. 1981. "Cone Resistance, Relative Density and Friction Angle." *Proceedings of the Cone Penetration Testing and Experience Session, ASCE National Convention, St. Louis, Oct 1981*, American Society of Civil Engineers, New York, NY.

Mitchell, Guzikowski, and Villet 1978

Mitchell, J. K., Guzikowski, F., and Villet, W. C. B. 1978. "The Measurement of Soil Properties In-Situ," Report No. LBL-6363, Lawrence Berkeley Laboratory, University of California, Berkeley.

Morgenstern and Eigenbrod 1974

Morgenstern, N. R., and Eigenbrod, K. D. 1974. "Classification of Argillaceous Soils and Rock," *Journal, Geotechnical Engineering Division*, Vol 100, No. GT10, pp 1137-1155, American Society of Civil Engineers, New York, NY.

Murphy 1985

Murphy, W. L. 1985. "Geotechnical Descriptions of Rock and Rock Masses," Technical Report GL-85-3, U.S. Army Engineer Waterways Experiment Station, Vicksburg, MS.

Nash 1993

Nash, K. 1993. "User's Guide for the Boring Log Data Manager, Version 2.0," Contract Report GL-93-1, U.S. Army Engineer Waterways Experiment Station, Vicksburg, MS.

Nelson and Miller 1992

Nelson, J. D., and Miller, D. J. 1992. *Expansive soils: Problems and practices in foundation and pavement engineering*. John Wiley & Sons, New York, NY.

Nicholson 1983a

Nicholson, G. A. 1983a. "Design of Gravity Dams on Rock Foundations: Sliding Stability Assessment by Limit Equilibrium and Selection of Shear Strength Parameters," Technical Report GL-83-13, U.S. Army Engineer Waterways Experiment Station, Vicksburg, MS.

Nicholson 1983b

Nicholson, G. A. 1983b. "In Situ and Laboratory Shear Devices for Rock: a Comparison," Technical Report GL-83-14, U.S. Army Engineer Waterways Experiment Station, Vicksburg, MS.

Olivier 1979

Olivier, H. J. 1979. "A new engineering-geological rock durability classification," *Engineering Geology*, Vol 14, pp 255-279.

Parry 1976

Parry, R. H. G. 1976. "Engineering Properties of Clay Shales: Report 3, Preliminary Triaxial Test Program on Taylor Shale from Laneport Dam," Technical Report S-71-6 Rpt 3, U.S. Army Engineers Waterways Experiment Station, Vicksburg, MS.

Parry 1977

Parry, R. H. G. 1977. "Estimating Bearing Capacity in Sand from SPT Values," *Journal, Geotechnical Engineering Division*, Vol 103, No. GT9, pp 1014-1019, American Society of Civil Engineers, New York, NY.

Peck, Hanson, and Thornburn 1974

Peck, R. B., Hanson, W. E., and Thornburn, T. H. 1974. *Foundation Engineering*. 2d ed., Wiley-Interscience, Somerset, NJ.

Perry 1979

Perry, E. B. 1979. "Susceptibility of Dispersive Clays at Grenada Dam, Mississippi, to Piping and Rainfall Erosion," Technical Report GL-79-14, U.S. Army Engineer Waterways Experiment Station, Vicksburg, MS.

Powers and Olhoeft 1995

Powers, M. H., and Olhoeft, G. R. 1995. GPRMODV2:One-Dimensional Full Waveform Forward Modeling of Dispersive Ground Penetrating Radar Data Version 2.0. USGS Open File Report 95-58, U.S. Government Printing Office, Washington, DC.

Priest 1993

Priest, S. D. 1993. *Discontinuity analysis for rock engineering*. Chapman and Hall, New York, NY.

Proctor and White 1977

Proctor, R. V., and White, T.L. 1977. *Rock Tunneling with Steel Supports*. Commercial Shearing Inc., Youngstown, OH.

Radbruch-Hall, Edwards, and Batson 1987

Radbruch-Hall, D.H., Edwards, K., and Batson, R.H. 1987. "Experimental engineering-geologic and environmental geologic maps of the conterminous United States," U.S. Geological Survey Bulletin 1610, U.S. Government Printing Office, Washington, DC.

Rasher and Weaver 1990

Rasher, M. E., and Weaver, W. 1990. *Basic Photo Interpretation*. Soil Conservation Service, National Cartographic Center, Fort Worth, TX.

Rinker et al. 1991

Rinker, J. N., Breed, C. S., McCauley, J. F., Corl, P. A. 1991. "Remote Sensing Field Guide - Desert," U.S. Army Corps Engineer Topographic Lab Manual ETL-0588, Fort Belvoir, VA.

Rocha 1970

Rocha, M. 1970. "New techniques in deformability testing of in situ rock masses," Determination of In Situ Modulus of Deformation of Rock, ASTM STP 477, American Society for Testing and Materials, Philadelphia, PA.

Schmertmann 1970

Schmertmann, J. H. 1970. "Static Cone to Compute Static Settlement Over Sand," *Journal, Soil Mechanics and Foundation Division*, Vol 96, No. SM3, American Society of Civil Engineers, New York, NY.

Schmertmann 1978a

Schmertmann, J. H. 1978a. "Guidelines for Cone Penetrometer Test, Performance and Design," FHWA-TS-78-209, Federal Highway Administration, Washington, DC.

Schmertmann 1978b

Schmertmann, J. H. 1978b. "Study of Feasibility Using Wissa-type Piezometer Probe to Identify Liquefaction Potential of Saturated Fine Sand," Technical Report S-78-2, U.S. Army Engineer Waterways Experiment Station Vicksburg, MS.

EM 1110-1-1804
1 Jan 01

Schroeder 1984

Schroeder, W. L. 1984. *Soils in Construction*, third ed., John Wiley & Sons, New York, NY.

Seed 1979

Seed, H. B. 1979. "Soil Liquefaction and Cyclic Mobility Evaluation for Level Ground During Earthquakes," *Journal, Geotechnical Engineering Division*, Vol 105, No. GT2, American Society of Civil Engineers, New York, NY.

Sen and Eissa 1991

Sen, Z., and Eissa, E. A. 1991. "Volumetric Rock Quality Designation," *ASCE Journal of Geotechnical Engineering*, Vol 117, No. 9.

Smith 1987

Smith, D. G. 1987. "A mini-vibracoring system," *Journal of sedimentary Petrology*, Vol 57, No. 4, pp 757-794.

Society of Exploration Geophysicist 1990

Society of Exploration Geophysicists. 1990. "Resistivity and induced polarization methods," *Geotechnical and Environmental Geophysics Volume I Review and Tutorial*. S. H. Ward, ed., Tulsa, OK, pp 147-190.

Stagg and Zienkiewicz 1968

Stagg, K. G., and Zienkiewicz, D. C. 1968. *Rock Mechanics in Engineering Practice*. 2nd ed., Wiley-Interscience, Somerset, NJ.

Star and Estes 1990

Star, J., and Estes, J. 1990. *Geographic Information Systems: An Introduction*. Prentice Hall, Englewood Cliffs, NJ.

Steeple and Miller 1990

Steeple, D. W., and Miller, R. D. 1990. "Seismic reflection methods applied to engineering, environmental, and groundwater problems," *Geotechnical and Environmental Geophysics Volume I Review and Tutorial*. Ward, S.H., ed., Society of Exploration Geophysicists, Tulsa, OK, pp 1-30.

Stover and Coffman 1993

Stover, C. W., and Coffman 1993. "Seismicity of the United States," U.S. Geological Survey Professional Paper 1527, U.S. Government Printing Office, Washington, DC.

Terzaghi, Peck, and Mesri 1996

Terzaghi, K., Peck, R. B., and Mesri, G. 1996. *Soil Mechanics in Engineering Practice*. 3rd ed., John Wiley & Sons, New York, NY.

Todd 1980

Todd, D. K. 1980. *Groundwater Hydrology*. John Wiley & Sons, New York, NY.

Tomlinson 1994

Tomlinson, M. J. 1994. *Pile Design and Construction Practice*, 4th ed., E & F N Spon, London.

Townsend and Gilbert 1974

Townsend, F. C., and Gilbert, P. A. 1974. "Residual Shear Strength and Classification Indexes of Clay Shales," Technical Report S-71-6, Report 2, U.S. Army Engineer Waterways Experiment Station, Vicksburg, MS.

Underwood 1967

Underwood, L. B. 1967. "Classification and Identification of Shales," *Journal, Soil Mechanics and Foundation Division*, Vol 93, No. SM6, pp 97-116, American Society of Civil Engineers, New York, NY.

U.S. Army Engineer Waterways Experiment Station 1954

U.S. Army Engineer Waterways Experiment Station. 1954. "Filter Experiments and Design Criteria," Technical Memorandum 3-360, Vicksburg, MS.

U.S. Army Engineer Waterways Experiment Station 1982

U.S. Army Engineer Waterways Experiment Station. 1982. *The Unified Soil Classification System*, Technical Memorandum No. 3-357, April 1960, reprinted Aug 1982. Office, Chief of Engineers, Washington, D.C.

U.S. Department of Interior, Bureau of Reclamation 1977

U.S. Department of Interior, Bureau of Reclamation. 1977. *Ground Water Manual*, Denver, CO.

U.S. Geological Survey 1973

U.S. Geological Survey. 1973. "Bibliography of North American Geology, 1970," USGS Professional Paper 1370, U.S. Government Printing Office, Washington, DC.

Vanadit-Ellis et al. 1995

Vanadit-Ellis, W., Woo, K. G., Edris, E. V., Jr., and Jobe, T. 1995. "Microcomputer Grouting Data Package (GDP): User's Guide, U.S. Army Engineer Waterways Experiment Station, Vicksburg, MS., unpublished report.

Varnes 1974

Varnes, D. J. 1974. "The Logic of Geologic Maps, with Reference to Their Interpretation and Use for Engineering Purposes," USGS Professional Paper 837, U.S. Government Printing Office, Washington, DC.

Walton 1970

Walton, W. C. 1970. *Groundwater Resource Evaluation*. McGraw-Hill, New York, NY.

Watts 1996

Watts, C. F. 1996. ROCKPACK II Rock Slope Stability Computerized Analysis Package, C. F. Watts and Associates, Radford, VA.

Woodward-Clyde Consultants 1996

Woodward-Clyde Consultants. 1996. "Instrumentation Database Package for Windows (WinIDP), User's Guide, Version 3.0," Produced for U.S. Army Engineer Waterways Experiment Station, Vicksburg, MS., unpublished.

EM 1110-1-1804
1 Jan 01

Zeigler 1972

Zeigler, T. W. 1972. "In Situ Tests for the Determination of Rock Mass Shear Strength," Technical Report S-72-12, U.S. Army Engineer Waterways Experiment Station, Vicksburg, MS.

Zeigler 1976

Zeigler, T. W. 1976. "Determination of Rock Mass Permeability," Technical Report S-76-2, U.S. Army Engineer Waterways Experiment Station, Vicksburg, MS.

Appendix B Geologic Mapping Procedures Open Excavations

B-1. Purpose of Excavation Mapping

The primary purpose of the excavation map and/or foundation geologic map is to provide a permanent record of conditions during excavation. This permanent record will assist in making the most equitable contract adjustments, provide otherwise unattainable information for use in diagnosing postconstruction problems and in planning remedial action, and allow for a better interpretation of postconstruction foundation instrumentation data. An important prelude to performing geologic mapping of the final foundation and/or excavation is monitoring conditions during excavation. Condition monitoring during excavation provides the basis for discovering, at the earliest possible moment, those adverse conditions (differing from original predictions) that may cause expensive design modifications and construction delays. Foundation and other excavation surfaces should not be covered until mapping is complete and approved by the project geologist or geotechnical engineer.

A plan for monitoring also provides a basis for installing appropriate instrumentation and interpreting foundation instrumentation data as the excavation proceeds. The Instrumentation Data Package (Woodward-Clyde Consultants 1996), a PC-based program, which can store, retrieve, and graphically present instrumentation data related to construction monitoring, will soon be available through the U.S. Army Engineer Waterways Experiment Station..

B-2. Possible Adverse Conditions

a. Adverse conditions can affect the stability of excavated slopes during construction, the stability of permanent slopes, foundation settlement, foundation bearing capacity, sliding stability of structures, and planned water control measures such as grouting and drainage requirements. Such conditions can occur in both soil and rock. Features of engineering significance in both soil and rock frequently occur in geometrically predictable patterns. The prediction of geometry is enhanced by knowledge of the local geologic history.

b. Adverse conditions that occur in soils include soft compressible zones of clay or organic materials; lateral compositional changes related to variations in depositional environment; changes in the relative density of granular materials; fill containing trash or other undesirable materials; swelling or slaking in hard, fissured clays; and changes in permeability.

c. Adverse conditions that can occur in rocks include weathering, soft interbeds in sedimentary and volcanic rocks, lateral changes, presence of materials susceptible to volume change (e.g., swelling clay shales, sulfide-rich shales, gypsum, and anhydrite), adversely oriented fractures (e.g., joints, bedding planes, schistosity planes, and shear planes), highly fractured zones, faults, joints, and shear planes filled with soft materials, and exceptionally hard layers that inhibit excavation or grout/drain hole drilling.

d. Adverse conditions related to ground water include unexpectedly high cleft or pore pressures which reduce effective stress, swelling materials, slaking, piping, sand runs, and uplift pressures on partially completed structures. It should be noted that most water-induced problems stem from unanticipated changes in the ground water regime.

B-3. Monitoring and Mapping Procedures

a. The difference between excavation monitoring and record mapping is small; both involve the observation and reporting of natural conditions. The need for monitoring the condition of slopes during construction include safety during construction and the prediction of conditions at grade. Potential problem areas can be detected and avoided, or corrective treatment can be started before a problem becomes severe.

b. Depending on the speed of excavation, monitoring should be performed on a daily, twice weekly, or weekly basis. Because of increasing steepness, rock slopes become less and less accessible as excavation progresses. Table B-1 is an excavation monitoring checklist, which, if followed, should ensure adequate coverage. Geologic sections can be constructed to assist in predicting the locations of features at grade. While many geologic features are arcuate or sinuous, many are planar. The location of a planar feature at grade can be found by graphic projection or by calculation as shown on Figure B-1.

c. Excavation and foundation mapping are generally performed on an intermittent and noninterference basis. If advantage is not taken of every mapping opportunity, the rock surface may be covered before another opportunity occurs or the contractor may be subjected to undue delay. Furthermore, systematic mapping makes for better monitoring. Thoroughness of mapping, type of mapping procedure, and sequence in which it is accomplished are functions of the purpose for which the mapping is required and of the construction schedule.

d. A number of items should be done to prepare for mapping before the excavation is begun.

(1) The geologist with mapping responsibility should make an interpretation, or confirm the existing interpretation of the geologic conditions (a geologic model). The geologist should decide on a mapping strategy and prepare field base map sheets. The map scale is partially dependent on the amount of detail to be mapped. If the excavation will be in hard, fractured rock, a field scale of 1 cm = 0.6 m (1 in. = 5 ft) and a final compiled map scale of 1 cm = 1.2 m (1 in. = 10 ft) would be suitable. If the excavated material is a soil, a soft, lightly fractured sedimentary rock, or a glacial till, field and compiled scales of 1 cm = 1.2 m (1 in. = 10 ft) and 1 cm = 6 m (1 in. = 50 ft), respectively, could be suitable. The field base maps should have reference lines for location purposes. In structure foundation areas, the structure outline will be enclosed by concrete forms that are easily located, making handy reference lines. The location of features inside reference lines can be facilitated by use of cloth tape grids, or with differential GPS.

(2) Decide at what intervals to map as the excavation progresses. Mapping intervals will be affected by a number of factors including the rate of excavation, lift thicknesses, and the need for temporary slope protection. In most cases, the mapping should be done in the plane of slopes; projection to other planes can be made after the mapping is completed. An exception occurs if mapping is done with a plane table. In this case, a horizontal reference plane is required. Camera positions should be selected for sequential photographs during excavation. Reference lines for mapping can be provided by stretching tapes from the top to bottom of the slope at 3- to 6-m (10- to 20-ft) intervals. Final excavation topographic maps should be made that can be used as a base for the geologic map.

(3) Determine whether the side slopes will be too steep for unassisted access. Temporary soil slopes usually range from IV on 3H to 1V on 1H. Temporary rock slopes usually range from 1V on 1H to vertical. It is not possible to walk slopes steeper than 1V on 1-1/2H unless they are very irregular. Thus, safety lines will be needed on most rock slopes and on some soil slopes.

Table B-1
Suggested Geologic Excavation Monitoring Checklist

Project _____

Excavation for _____ Structure

Period: _____ To _____

1. Excavation Progress:
 - a. Type Excavation: (common or rock) _____
 - b. Location: Sta _____ To _____ Offset _____
2. Rock or soil type: _____
3. Rock or soil conditions: (hardness, stiffness, weathering, fracturing, sloughing, etc.) _____
4. Water inflow, locations and gpm: _____

5. Significant features or defects: (those which may cause problems (and/or may extend to grade) _____
6. Slope protection: (protection or reinforcement, location, type thickness, etc.) _____
7. Blasting conditions: (presplitting locations and successes, production blasting, powder factor, hole spacing, delay patterns, deviations from approved rounds, fragment size, overbreak, etc.) _____

8. Ripping conditions: (single or multitooth, drawbar horsepower, easy or hard, disturbance below grade or slopes) _____
9. Additional remarks: (unusual incidents, accidents, explorations, etc.) _____

10. Mapping progress:
 - a. Location _____
 - b. Adequacy of coverage (rock surface clean?, percent obscured by slope protection?, etc.) _____

 - c. Photos taken: _____ (where, or what) _____

11. Instrumentation installed:
 - a. Location _____
 - b. Type and amount _____

12. Instrumentation read:
 - a. Location _____
 - b. Type _____

(4) Where the slopes are nearly vertical, consideration can be given to mapping on large-scale photographs. However, there must be time to produce the photographs for use as a map base.

e. It is desirable to have a contract provision for interim rock surface cleanup. The final foundation cleanup item will suffice for mapping purposes at final grade. However, the need may arise for detailed examination of particular areas during excavation. Excavation slopes may need sealing or other interim protection against weathering.

f. During mapping, complete descriptions of all geologic features should be made (e.g., rock types, bedding, fracturing, joints, shear zones, etc.). All features, geologic and otherwise (including ledges and

breaks in slope), should be located and drawn on the base map. Table B-2 provides descriptive criteria for use during mapping.

g. To the maximum extent possible, U.S. Geological Survey (USGS) map symbols or variations of these symbols should be used. In most cases, the geologist should represent geologic features by showing the trace of the feature on the map. The trace will allow a reasonably accurate location of each significant feature.

h. Frequently, foundation maps and sections are prepared with rock type symbols covering the entire area of the particular rock type. However, if all the recognizable distinct geologic features are also located on the drawing, it will be cluttered and difficult to read. Thus, the primary purpose of the foundation record will be obscured. Each mark on the foundation map should have physical significance.

i. Records should be made of foundation treatment, such as grout hole locations, dental work, pneumatic concrete, rock-bolt locations, and wire mesh. Portrayal of such treatment can be included on the geologic map. However, if the resulting map is too cluttered, either the treatment should be portrayed in a series of transparent overlays, or the scale of the mapping should be enlarged. A Geographic Information System (GIS) is ideal for subdividing the geotechnical (and other construction) information into a series of data layers that can be digitally overlaid. In a GIS, map scales can easily be altered, and adjustments of the geotechnical information can readily be accomplished for presentation in a comprehensible format.

j. The importance of adequate photography and videos of the excavation process and the final slope and foundation conditions cannot be overemphasized. Complete video and photographic coverage is as important as the foundation maps. All are required for an accurate and complete record of encountered conditions. Photographs and videos can be readily incorporated into a GIS.

k. The photographic coverage should include unobstructed, medium-scale photographs of the entire foundation and closeup views of significant geologic features; a photograph through a mat of reinforcing steel is useless. All photographs should be annotated by the geologist and clearly sited on a photograph location map.

B-4 Examples of Foundation Maps

Figures B-2 through B-8 are examples of foundation maps. Figures B-2 and B-3 depict foundation maps for concrete structures in metavolcanic and igneous rocks where the geologists have attempted to portray the entire trace of all significant geologic features. Figure B-4 is a tunnel map in the same kinds of materials as portrayed in Figure B-3 and also provides a legend for Figure B-3. Figure B-5 is a smaller scale map of an excavation in metavolcanic rocks and also includes the foundation mapped in detail in Figure B-3. Figure B-6 is a foundation map for the impervious core of an earth dam founded on metavolcanic and igneous rocks. The geologist has mapped the full traces of shears, contacts, and igneous dikes but has shown joints and lineations by symbols only. Figure B-7 depicts a detailed foundation map for a concrete structure founded in sedimentary rocks. The geologist has located the full trace of all significant geologic features. Figure B-8 depicts the foundation for a cutoff trench in sedimentary rocks.

Table B-2
Descriptive Criteria, Excavation Mapping

1. Rock Type.

a. Rock Name (Generic).

b. Hardness.

- (1) Very soft: can be deformed by hand.
- (2) Soft: can be scratched with a fingernail.
- (3) Moderately hard: can be scratched easily with a knife.
- (4) Hard: can be scratched with difficulty with a knife.
- (5) Very hard: cannot be scratched with a knife.

c. Degree of Weathering.

- (1) Unweathered: no evidence of any mechanical or chemical alteration.
- (2) Slightly weathered: slight discoloration on surface, slight alteration along discontinuities, less than 10 percent of the rock volume altered, and strength substantially unaffected.
- (3) Moderately weathered: discoloring evident, surface pitted and altered with alteration penetrating well below rock surfaces, weathering "halos" evident; 10 to 50 percent of the rock altered, and strength noticeably less than fresh rock.
- (4) Highly weathered: entire mass discolored, alteration pervading nearly all of the rock with some pockets of slightly weathered rock noticeable, some minerals leached away, and only a fraction of original strength retained (with wet strength usually lower than dry strength).
- (5) Decomposed: rock reduced to a soil with relict rock texture (saprolite), and generally molded and crumbed by hand.

d. Lithology, Macro Description of Mineral Components. Use standard adjectives such as shaly, sandy, silty, and calcareous. Note inclusions, concretions, nodules, etc.

e. Texture and Grain Size.

(1) Sedimentary rocks:

<u>Texture</u>	<u>Grain Diameter</u>	<u>Particle Name</u>	<u>Rock Name</u>
*	80 mm	Cobble	Conglomerate
*	5 to 80 mm	Gravel	
Coarse grained	2 to 5 mm		Sandstone
Medium grained	0.4 to 2 mm	Sand	
Fine grained	0.1 to 0.4 mm		
Very fine grained	0.1 mm	Clay, silt	
			Shale, claystone, siltstone

* Use clay-sand texture to describe conglomerate matrix.

(2) Igneous and metamorphic rocks:

<u>Texture</u>	<u>Grain Diameter</u>
Coarse grained	5 mm
Medium grained	1 to 5 mm
Fine grained	0.1 to 1 mm
Aphanite	0.1 mm

(Sheet 1 of 3)

Table B-2 (Continued)

- (3) Textural adjectives: Use simple standard textural adjectives such as porphyritic, vesicular, pegmatitic, granular, and grains well developed, but not sophisticated terms such as holohyaline, hipidiomorphic granular, crystalloblastic, and cataclastic.
2. Rock Structure.
- a. Bedding.
- (1) Massive: 3 ft thick.
 - (2) Thick bedded: beds from 1 to 3 ft thick.
 - (3) Medium bedded: beds from 0.3 ft to 1 ft thick.
 - (4) Thin bedded: beds less than 0.3 ft thick.
- b. Degree of Fracturing (jointing).
- (1) Unfractured: fracture spacing 6 ft.
 - (2) Slightly fractured: fracture spacing 3 to 6 ft.
 - (3) Moderately fractured: fracture spacing 1 to 3 ft.
 - (4) Highly fractured: fracture spacing 0.3 to 1 ft.
 - (5) Intensely fractured: fracture spacing 0.3 ft.
- c. Shape of Rock Blocks.
- (1) Blocky: nearly equidimensional.
 - (2) Elongated: rodlike.
 - (3) Tabular: flat or bladed.
3. Discontinuities.
- a. Joints.
- (1) Type: bedding, cleavage, foliation, schistosity, and extension.
 - (2) Separations: open or closed; how far open.
 - (3) Character of surface: smooth or rough; if rough, how much relief; average asperity angle.
 - (4) Weathering or clay products between surfaces.
- b. Faults and Shear Zones.
- (1) Single plane or zone: how thick?
 - (2) Character of sheared materials in zone.
 - (3) Direction of movement, and slickensides.
 - (4) Clay fillings.
- c. Solution Cavities and Voids.
- (1) Size.

(Sheet 2 of 3)

Table B-2 (Concluded)

- (2) Shape: planar, irregular, etc.
- (3) Orientation: (if applicable) developed along joints, bedding planes, at intersections of joints and bedding planes, etc.
- (4) Filling: percentage of void volume and type and of filling material (e.g., sand, silt, clay, etc.).

(Sheet 3 of 3)

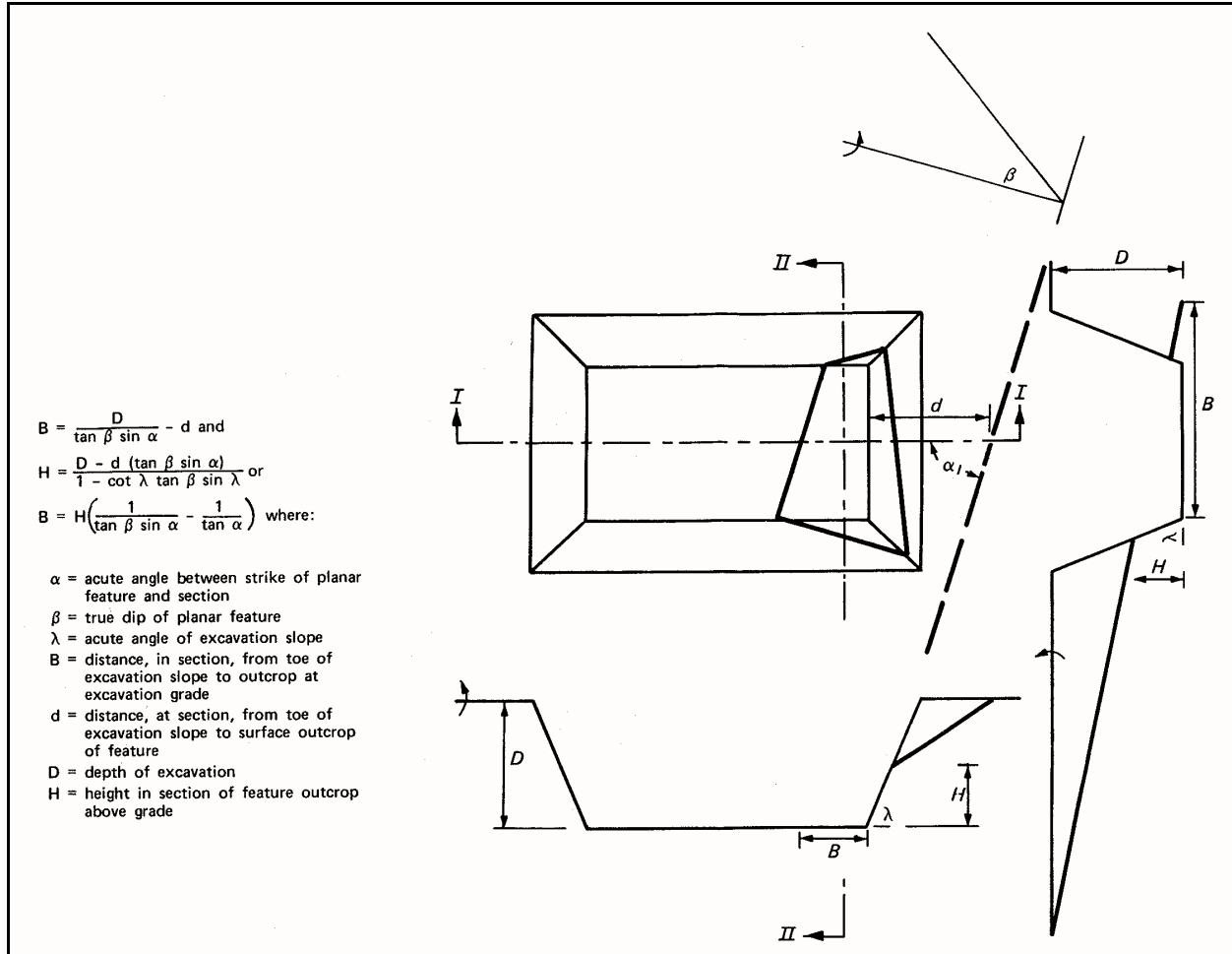

Figure B-1. Excavation plan and sections showing intersecting planar feature

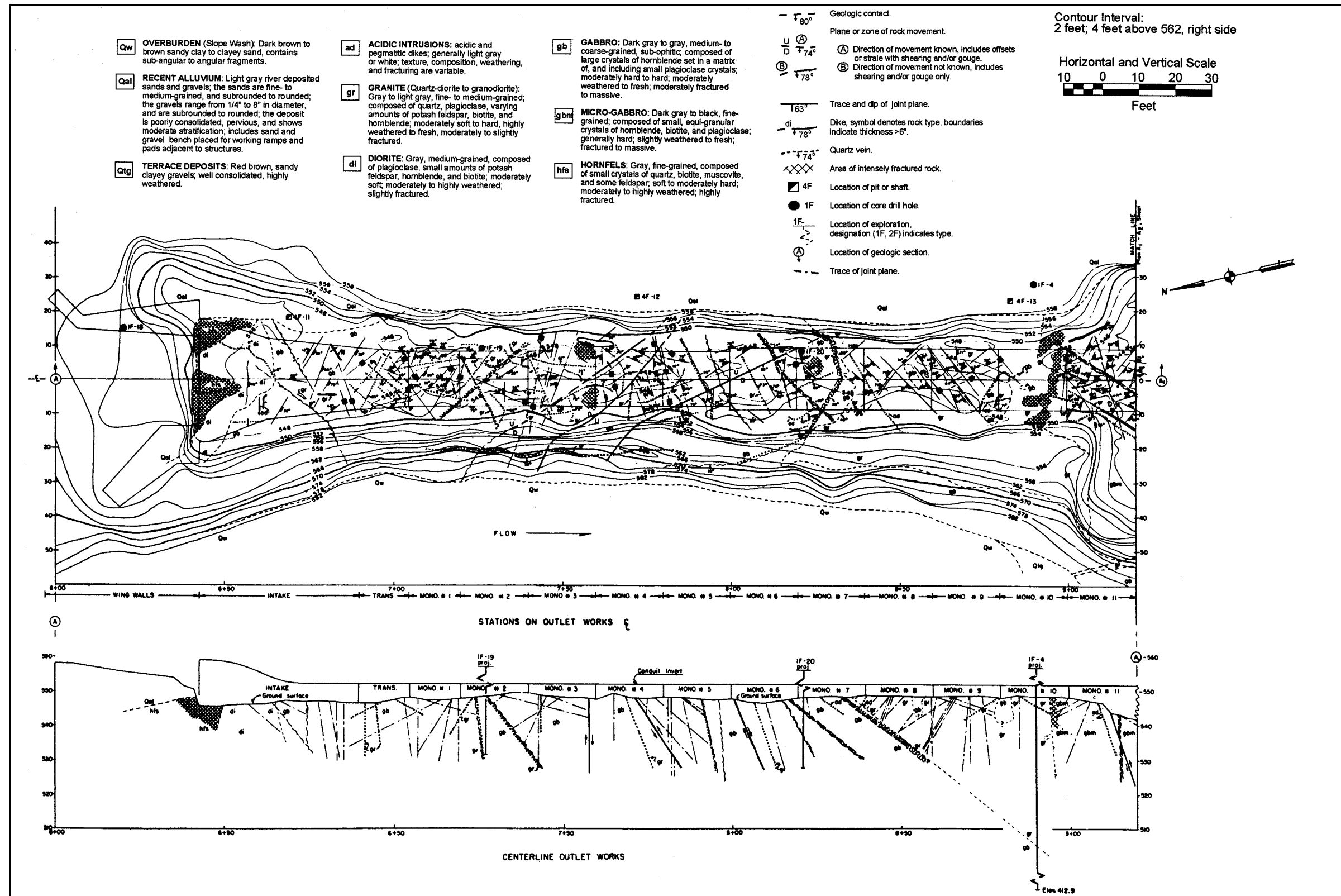

Figure B-2. Example of a foundation map for concrete structure on metavolcanic and igneous rocks

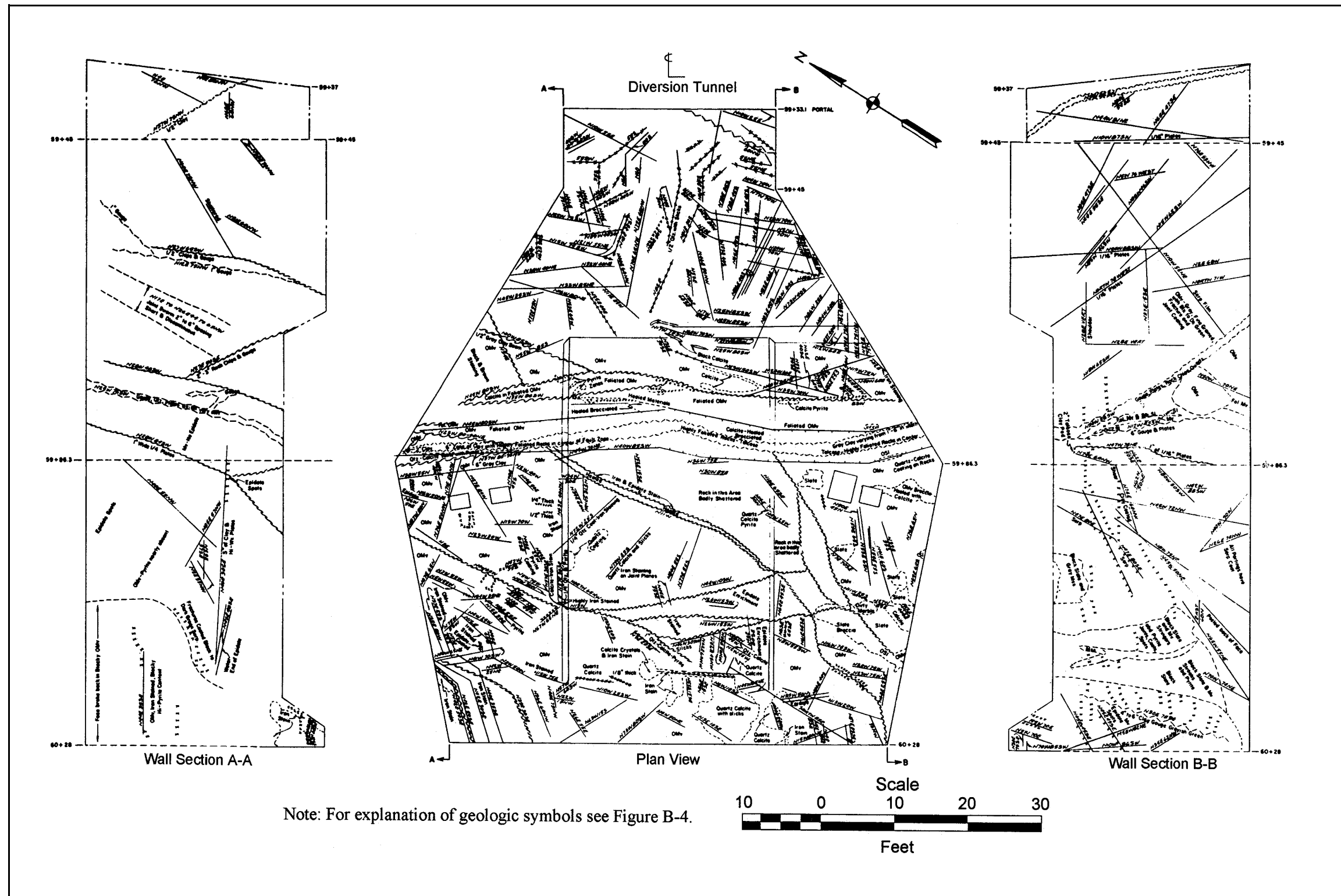

Figure B-3. Example of foundation map for structure on metamorphic rocks

EXPLANATION OF SYMBOLS FOR FIGURE B-3

- Mv **METAVOLCANICS:** Grayish green, moderately hard to hard; fine-grained to fragmented; contains visible amounts of dark green pyroxene, calcite, quartz, and epidote.
- Mss **META SANDSTONE:** Black to dark gray, moderately hard to hard; fine-grained; massive; variable amounts of metavolvanic fragments and black slate.
- S1 **SLATE:** Black, moderately hard; fine-grained; moderately fissile; contains variable amounts of calcite and pyrite.
- S1br **SLATE BRECCIA:** Black with gray streaks; moderately hard; contains layers and fragments of metasandstone and metavolvanic rock in a slaty groundmass; crudely foliated.

OLDER METAMORPHICS

- OMv **METAVOLCANICS:** Light gray to gray; moderately soft to moderately hard; fine-grained; crudely to moderately foliated; contains black slate streaks.
- TOMv **METAVOLCANICS:** Partially replaced by soapstone or talc.
- OS1 **SLATE:** Black; moderately soft to moderately hard; fine-grained; moderately fissile to fissile.
- OTS1 **SLATE:** Partially replaced by soapstone or talc.
- OS1br **SLATE BRECCIA:** Dark gray to black; moderately hard; contains angular fragments of metasandstone and metavolvanic; moderately fissile.
- OMvc **METAVOLCANICS: CONGLOMERATE:** Greenish gray, moderately hard to hard; fine-grained metavolvanic groundmass enclosing rounded fragments of metavolvanic, metasandstone, chert, marble, and slate.
- OMss **META SANDSTONE:** Gray, fine- to medium-grained; moderately hard.
- Mar **MARBLE:** Gray; moderately hard; finely crystalline.
- Serp **SERPENTINE:** Dark green to black; soft to moderately hard; waxy luster; partially to completely replaces surrounding rock types.
- Md **MICRODIORITE DIKES:** Gray; moderately hard; fine- to medium-grained; contains numerous transverse quartz calcite seams and are from 5 to 46 cm (2 to 18 in.) wide.
- xxx **QUARTZ-CALCITE:** Veins.

cont. contorted

fol. foliated

stks. streaks

crud. crudely

○ grout hole

● IF-1 core hole

$\frac{N69W}{50S}$ strike and dip of joint

$\frac{N10W}{60E}$ strike and dip of cleavage

----- geologic contact

~~~~~ fault

~~~~~ shear

Notes:

1. Hard - difficult to scratch with a knife.
2. Moderately Hard - can be easily scratched with a knife.
3. Moderately Soft - can be carved with a knife.
4. Soft - can be gouged with a copper penny.
5. Very Soft - can be gouged with a finger nail.
6. See text for detailed rock description.

Figure B-4. Explanation of symbols

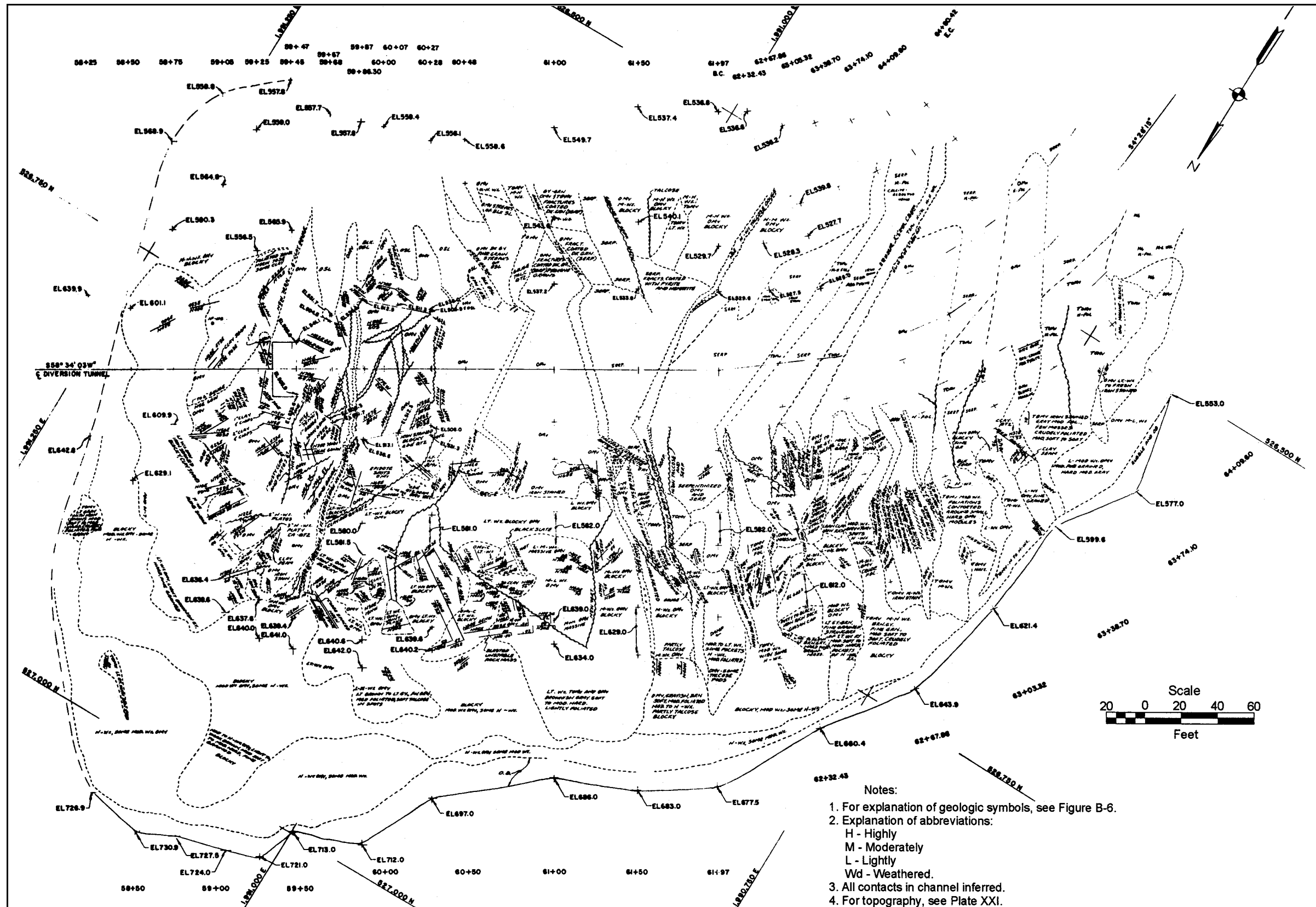

Figure B-5. Example of excavation map including area covered by Figure B-3

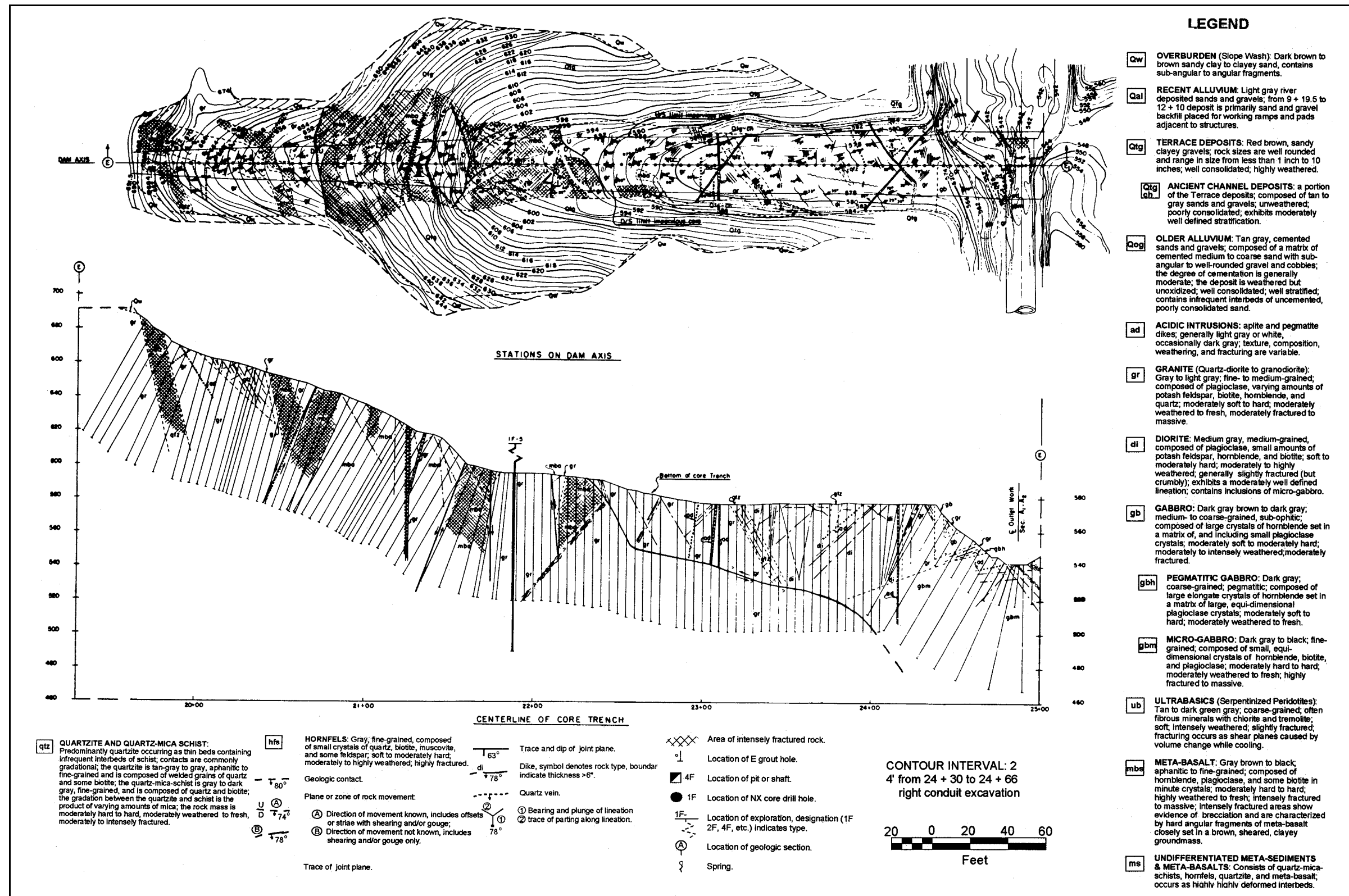

Figure B-6. Example of foundation map for earth dam impervious core on meta-volcanic and igneous rocks

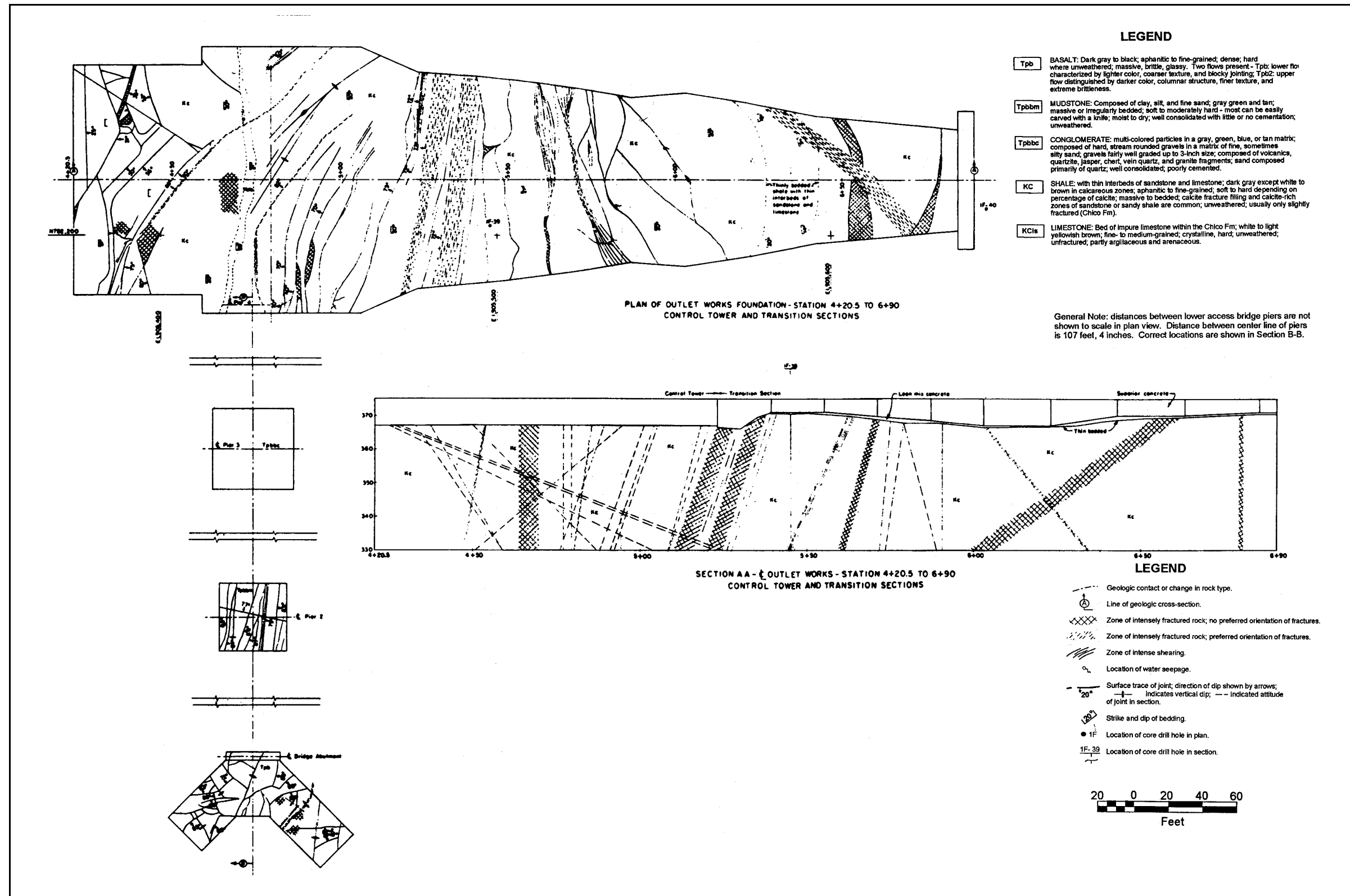

Figure B-7. Example of foundation map for concrete structure on sedimentary rocks

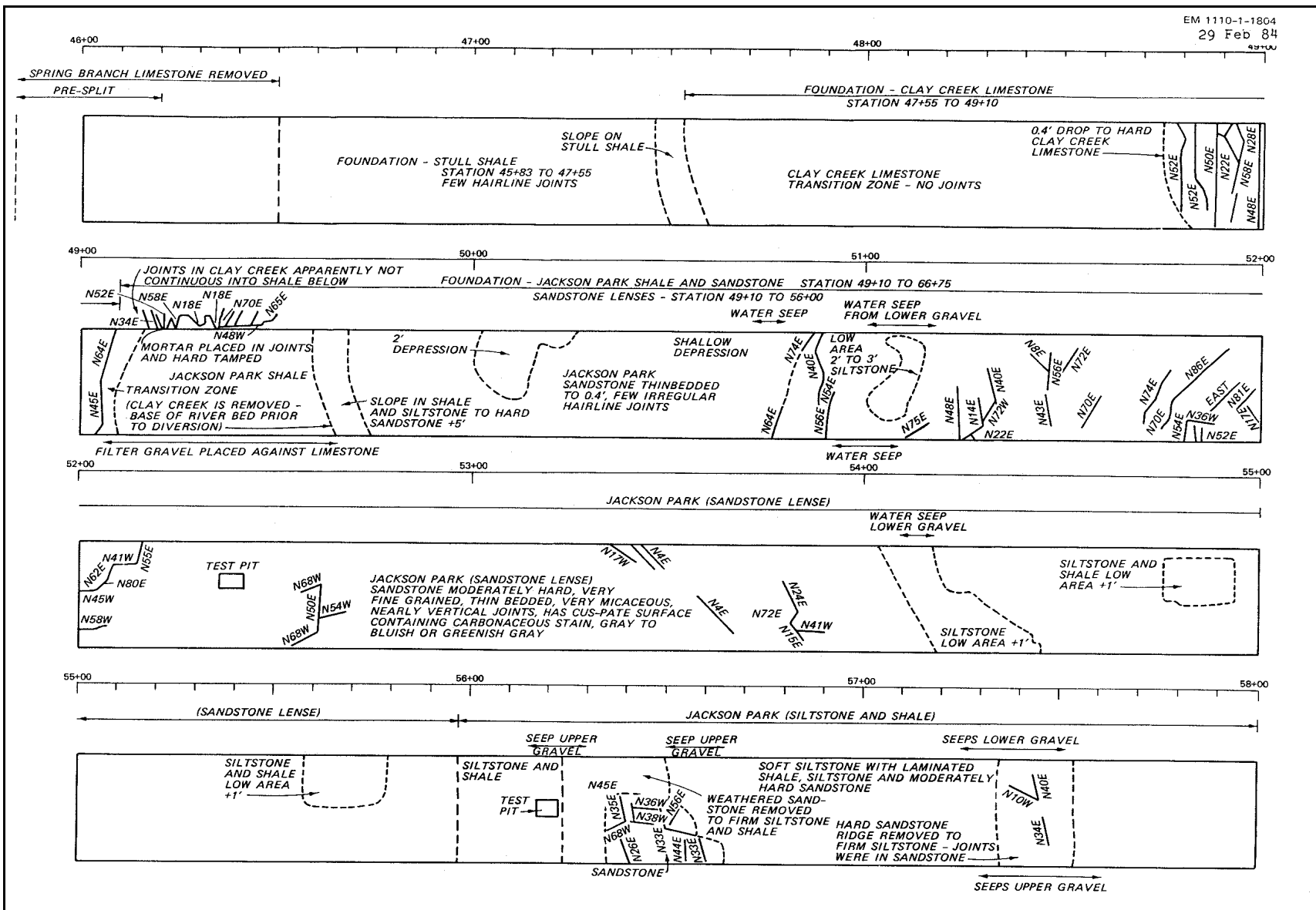

Figure B-8. Foundation map for earth dam impervious core on sedimentary rocks (note: 1 ft = 0.3 m)

Appendix C Geologic Mapping of Tunnels and Shafts

C-1. Background

A method to log all geologic features exposed by underground excavations has been developed by U.S. Army Engineer District, Omaha, geologists wherein all necessary data of a specific geologic discontinuity can be recorded at a single point; thus the system may be used in tunnels of almost any configuration and inclination. This method is called peripheral geologic mapping. It allows logging of all geologic defects regardless of their position on the tunnel walls. Furthermore, this method usually will keep pace with modern continuous mining techniques and will immediately provide useful data without projecting to plan or profile. Prior to development of this method, the accepted method was to project geologic features to a plan placed tangent to a point on the tunnel circumference. Ordinarily such tangent points were at springline, wasteline level, or crown. In many instances, geologic features not passing through these points were not logged. Further, some systems were useful for logging planar discontinuities only, such as joints, faults, and bedding planes, as exposed in straight, nearly horizontal tunnels of circular cross section. Peripheral geologic mapping uses a developed plan by “unrolling the circumference” to form a plan of the entire wall surface. A log of the exposed geology is plotted on this plan as mining progresses. Mapping on a developed layout of a cylindrical surface is similar to the method used to log the interior of a calyx hole. Actually, a circular tunnel might be visualized as a large horizontal or nearly horizontal drill hole.

C-2. Applications

Peripheral geologic mapping may be used to log large-diameter power tunnels and surge tank risers (both straight and wye-shaped), vertical shafts, horseshoe-shaped drifts and chambers, and odd-shaped openings on both civil and military projects. It can be used to map a wide range of geomaterials from stratified, soft, sedimentary rocks to hard igneous and metamorphic rock masses. The method has proved to be simple enough mechanically that technicians can be trained to perform round-the-clock mapping under the general supervision of a professional geologist - a necessity where several parallel tunnels are driven simultaneously. This method is not applicable to TBM driven tunnels with precast liners where mapping may be impracticable or impossible.

C-3. Procedure

a. Advance planning is of paramount importance. The developed layouts on which mapping will be done should be prepared well in advance. Usually this step in the procedure can be accomplished by using the contract plans. A thorough surface and subsurface study of the geology of the immediate area is recommended. This study enables the mapper to recognize which geologic features are important and readily identify them on the excavation walls.

b. The map is typically laid out to a scale of 1 cm = 1.2 m (1 in. = 10 ft) In some instances where closely spaced geologic discontinuities are anticipated, a scale of 1 cm = 0.6 m (1 in. = 5 ft) should be considered. To prepare a mapping plan, draw the crown center line of the tunnel in the center of the plan. Place the center line of the invert at both the right- and left-hand edges of the developed layout. The right and left springlines of a circular tunnel will be midway between the center line and edges of the plans (Figure C-1). Distances down the tunnel may be laid out on tunnel stationing. Separate developed plan tracings are typically made for 100-ft lengths of tunnel. For long reaches of equal-diameter tunnel, a master tracing may be repeatedly printed on a continuous length of paper to cover the entire tunnel

length. For continuous uninterrupted printing, use three master tracings. This long sheet of paper may be rolled up and carried in the field in the form of a scroll.

c. Intermediate control points should be added wherever possible to more precisely locate points along geologic discontinuities. On Figure C-2, which is a mapping sheet used at Fort Randall Dam, South Dakota, the horizontal distances from the center line and vertical distances from springline were computed and drawn on the developed plan to form a grid. When plotting a point, the mapper measures these two distances (horizontal distance from center line and vertical distance above or below springline) and plots the point at the proper tunnel stationing. To eliminate long measurements in large-diameter tunnels, distances were actually measured from fixed known points on the tunnel support ring beams (splices, bolt holes, and spreader bars). At Oahe Dam, South Dakota, horizontal and vertical distances of fixed features on the ring beam supports were drawn on the mapping sheets as lines so that points on geologic features could be plotted from the nearest ring beam reference point. On Figure C-3, which is a mapped portion of Oahe Dam power tunnel No. 2, a developed ring beam is shown at the top of the page, vertical distances from springline of identifiable fixed points on the ring beam are shown along the top of the mapping section, and horizontal distances from center line of these same points are shown along the bottom of the mapping section. The ring beam number and its tunnel station is shown along the right-hand edge. Excellent mapping control was thus provided on this project. In excavations not requiring close checks on alinement, control points may be almost nonexistent. In such cases, the mapper must establish his own control points. He may have to stretch a tape along the tunnel from the nearest spad, then mark stationing at 1.5- or 3-m (5- or 10-ft) intervals along the walls and use an assumed elevation at his reference point. Obviously, the resultant geologic log will not be as accurate, but the relative position of discontinuities should remain constant from tunnel wall to geologic log.

d. The conventional method of measuring the strike, or orientation of a joint, shear, or fault, by magnetic needle (Brunton) compass is not reliable in most underground work because of the proximity to electrical circuits, reinforcing steel, or support steel. Also in some areas, the rock mass itself may be magnetic. To overcome this problem, an adjustable protractor can be devised. Essentially, it is an instrument for measuring the angle between the trend of a planar geologic defect, as measured in the horizontal plane, and the bearing of the tunnel center line. The protractor is fitted with a revolving pointer, which rotates around the center point of the protractor. The baseline of the protractor is held parallel to the tunnel center line, the pointer is sighted along the strike of the discontinuity, and the angle is read on the protractor at the point where a line scribed on the pointer coincides with the degree lines on the protractor arc (Figure C-4). The strike of the geologic defect is then computed from the observed angle and the bearing of the tunnel. In small-diameter drifts, tunnels, adits, etc., a small, light, fixed-base protractor will be adequate for fairly accurate readings. In large-diameter openings, a special protractor may be constructed that has an adjustable baseline. The baseline of the instrument is then revolved to the known tunnel bearing so that direct readings of strike may be taken (Figure C-4). A circular spirit-level bubble may be mounted on the instrument to assure that readings are in the horizontal plane. Dip readings are observed by using the inclinometer on a Brunton compass or pocket transit.

C-4. Helpful Suggestions

a. The geologic features that have the greatest effect on the physical and engineering properties of the rock mass should be logged first. A classification for rock masses for tunnel support are described in EM 1110-2-1901. Geologic logging should be performed near the heading as fresh rock is exposed, before the exposed walls become dust covered or smeared over, and before the geologic features are partially or completely covered by tunnel supports, lagging, pneumatically placed mortar, etc. The mapper should ensure that adequate lighting is available. Mapping should be from the back of the mining machine or on the drill jumbo to help the mapper reach the higher sidewalls and crown in

large-diameter tunnels. The main geologic features, such as faults, joints, shear zones, bedding planes, and clay seams, should be carefully plotted first. Then as time permits, other less important features may be filled in between the previously plotted features on the geologic log. Additional features to be logged include fractures, stressed zones, fallouts, water seeps, etc. These features make up only a partial list because additional important geologic features will be encountered at each specific project.

b. In large- and medium-diameter tunnels, consecutive mapping sections may be printed on a long sheet of paper to form a scroll. This continuous length of paper can be carried on a mapping board so designed that only the section being mapped is exposed while the remainder of the roll is enclosed in boxes on each side of the mapping board. Cranks and rollers may be added to assist in moving the proper section onto the mapping board. The board may be faced with a piece of sheet metal to provide a smooth writing surface. In small or odd-shaped tunnels or drifts, the mapping sheets are usually carried in individual, conveniently sized sections. A covered clipboard makes a good mapping board. The cover is to protect the mapping sheets from the ever present dust, moisture, etc., associated with underground excavations.

If necessary, the mapper can extend his own control from known points. A steel tape is stretched along the tunnel and 1.5- or 3-m (5- or 10-ft) station intervals may be marked on the wall or supports with spray paint. Photographs of important or unusual geologic features are a valuable addition to the mapping. It is also suggested that a small portable tape recorder for noting the location and attitude of secondary features will help the mapper, especially in adding secondary features to the mapping when time in the tunnels is limited.

c. The completed geologic log of a horizontal or nearly horizontal tunnel will wrap around a mold of proper dimensions to form a model with the mapped features and recorded information in their proper position; however, the geologic log of peripheral mapping in a vertical shaft or end face will not be in its proper position unless the information is traced through the paper to reverse the image. The reversal of the image presents no particular problem because in most instances the field maps and data are transcribed to finished drawings in the office. The geologic section in Figure C-5 was not reversed; therefore the observer appears to be in the shaft looking outward. Also in odd-shaped raises or in vertical shafts, it is difficult for the mapper to remain properly oriented unless vertical reference points around the periphery have been surveyed-in prior to the start of geologic mapping.

C-5. Analysis of Data

a. Although peripheral geologic logging, or mapping, provides a permanent record of all geologic defects exposed on the walls of an underground excavation, maximum benefits cannot be gained unless the data are properly studied and analyzed. One study method is cutting and trimming the drawings and forming them into the proper shape for three-dimensional viewing, which causes the relationship of discontinuities to the tunnel geometry to become much more apparent.

b. Projection of the trace of geologic discontinuities to two-dimensional plans or profiles may be made, but not directly, because the mapping has been done on a developed plan. One method of transferring data to plan is by plotting to corresponding stationing. Data may be transferred to profile, or cross section, by plotting the points where the discontinuities intersect measured stationing at crown, invert, and/or springline. Where only one point can be plotted, the trace of the discontinuity may be extended along a line drawn on the recorded strike or dip of a discontinuity (the use of apparent dip may also be necessary). Figure C-6 illustrates a method of projecting geologic data to sections drawn through a circular tunnel.

c. Statistical studies may be made from the accumulated data. By counting all discontinuities per unit of length and circumference, an average piece size or block size may be determined. Plotting the trends of joints, faults, and shears on equal-area nets and stereographic projections (Hobbs, Means, and Williams 1976)¹ will help determine the major and minor joint sets and the preferred orientation of faults and shear zones. Another method of statistical analysis might be by making rosette plots of the joints and shears.

C-6. Uses for Geologic Data

The value of peripheral geologic mapping has been proven many times. Below are listed some of the uses for this type of geological logging.

- a.* Predicting geologic conditions in intermediate tunnels where driving a series of parallel tunnels .
- b.* Projecting geology from the pilot drift to the full bore of a tunnel before enlarging is started.
- c.* Planning tunnel support systems and selecting the best location and inclination of supplemental rock bolts.
- d.* Maintaining a record of difficult mining areas, overbreak and fallout, and mining progress by daily notation of the heading station. This type of record is valuable in changed condition claims.
- e.* Comparing cracking of concrete tunnel liners with weaknesses logged in tunnel walls.
- f.* Analyzing stress conditions around tunnel openings using methods that evaluate the spacing and orientation of geologic discontinuities.
- g.* Choosing strategic locations for various types of instrumentation to study tunnel behavior.
- h.* Selecting the best locations for pore pressure-type piezometer tubes where it is desirable to position them to intercept particular types of discontinuities at specific elevations near previously driven tunnels.

Proctor and White (1977) and Dearman (1991) also provide useful information regarding the geotechnical aspects of rock tunneling.

C-7. Examples

a. The preceding description of peripheral geologic mapping was based primarily on logging, which was done in circular, nearly horizontal tunnels and vertical circular shafts. With some modifications and a degree of ingenuity, the method can be adapted to almost any shape of underground opening. For some projects, the preplanned developed layouts may have to be made by using patterns taken from heating and cooling ductwork manuals.

b. Figures C-7 through C-9 are offered for general guidance only. The method may be modified to fit anticipated conditions peculiar to a specific project. For example, in Figure C-8 only the curved

¹ References are listed in Appendix A.

portion above springline was laid out on a developed plan and the vertical sidewalls below springline were laid out on true scale. No provisions were made for mapping the drift floor because it was not cleaned sufficiently to expose the geological features.

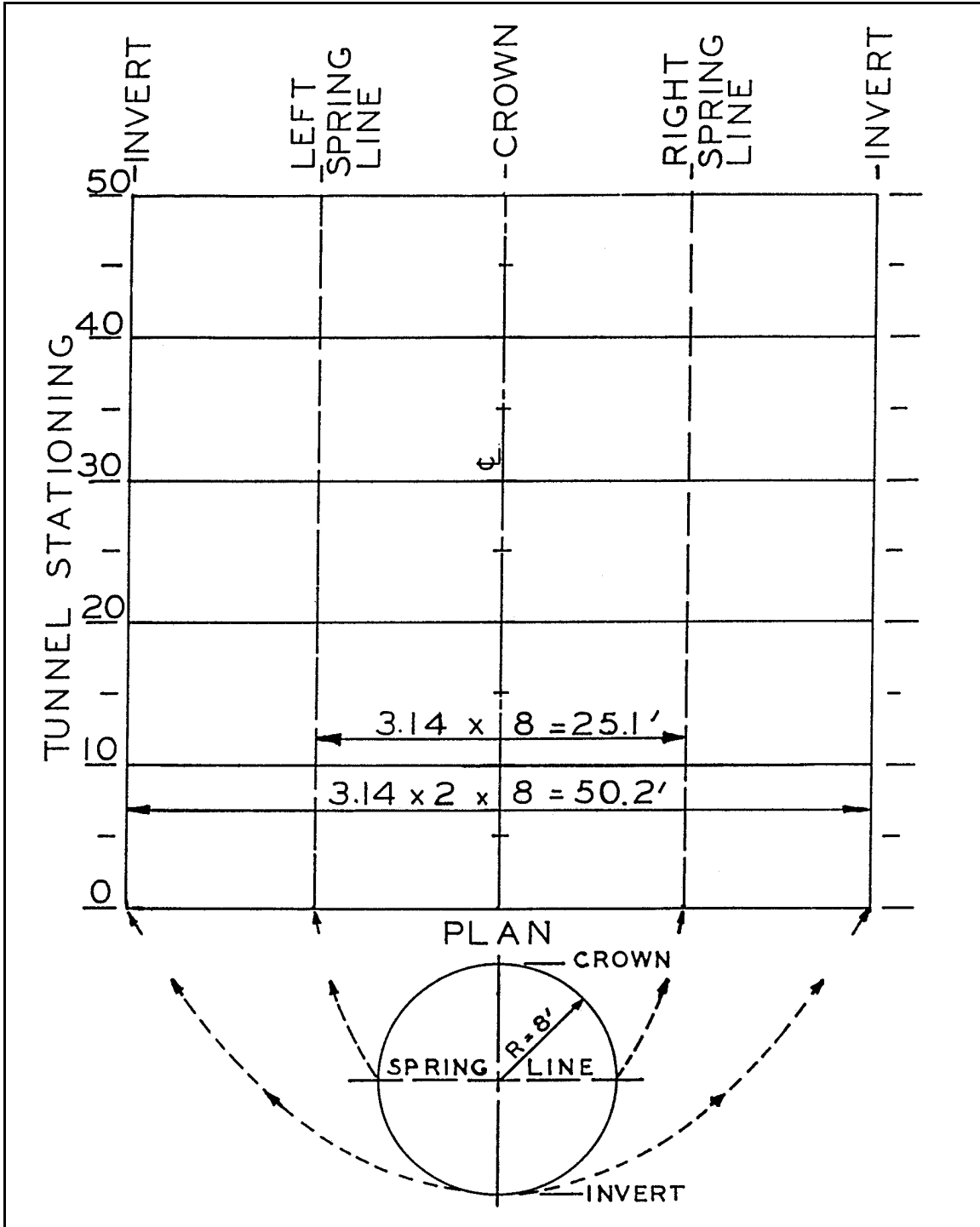

Figure C-1. Preparation of developed plan from a cylindrical cross section

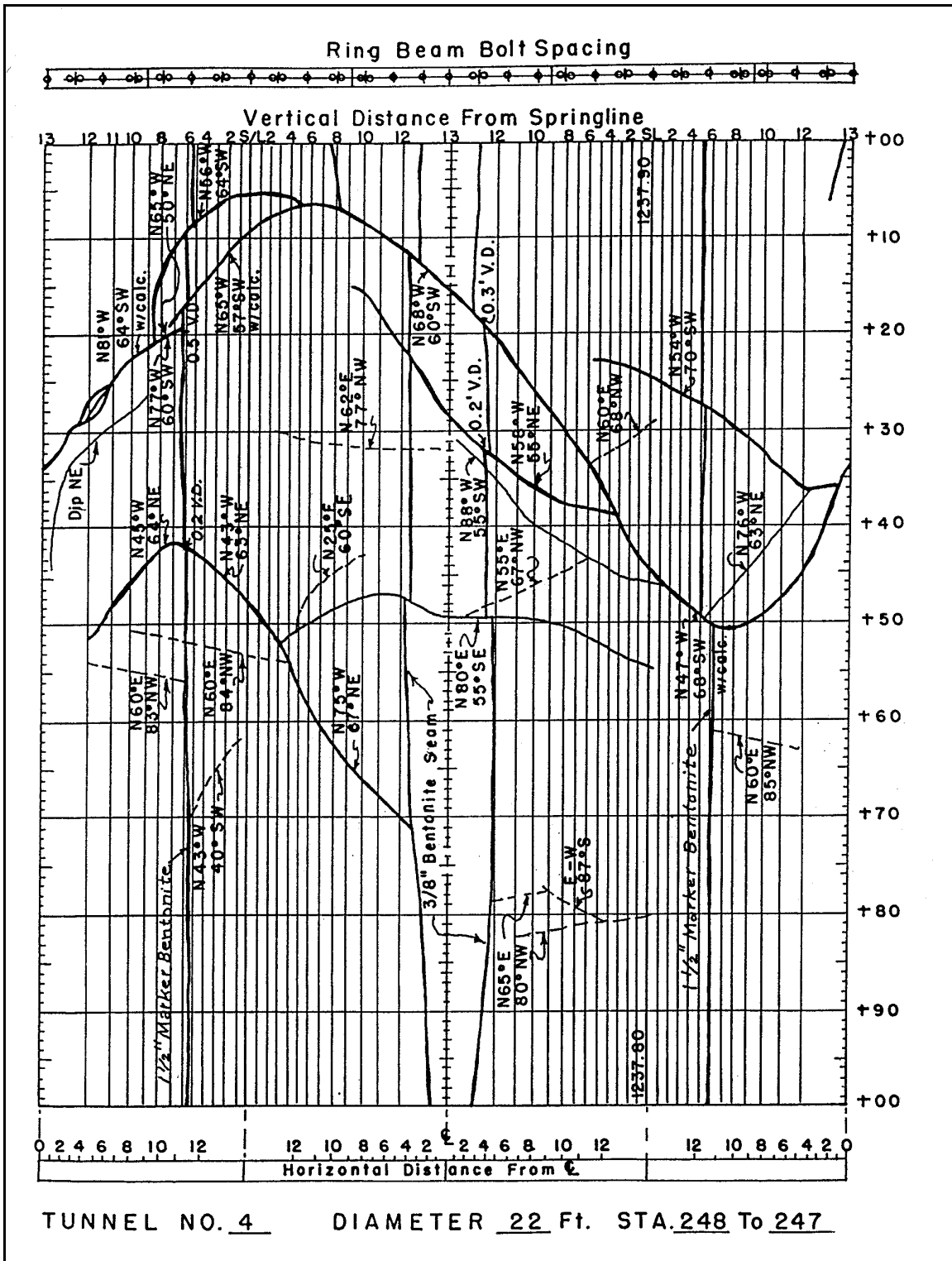

Figure C-2. Developed plan of cylindrical tunnel section Fort Randall Dam, South Dakota (note: 1 ft = 0.3 m approx.)

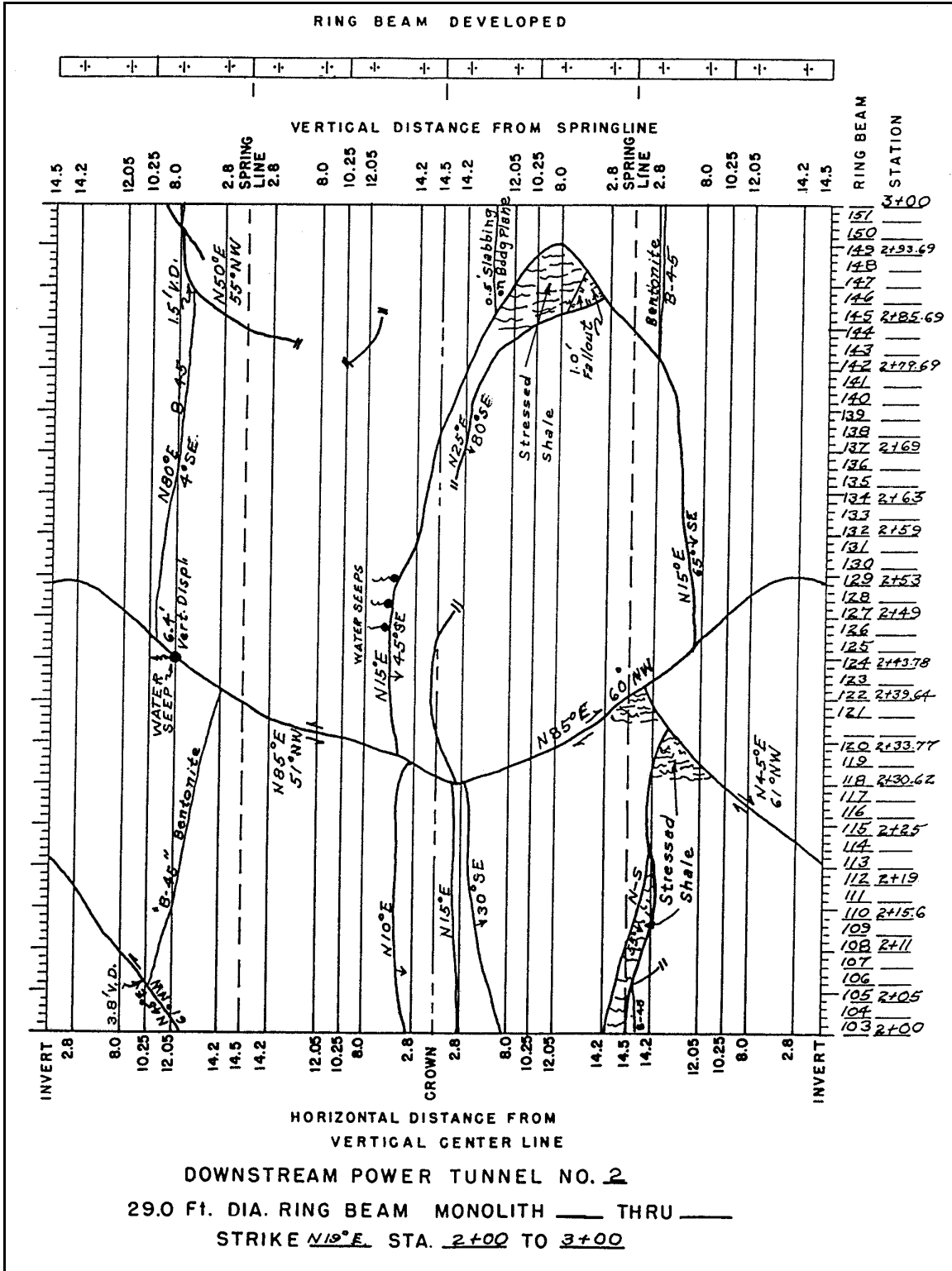

Figure C-3. Developed plan of cylindrical tunnel section Oahe Dam, South Dakota (note: 1 ft = approx. 0.3 m)

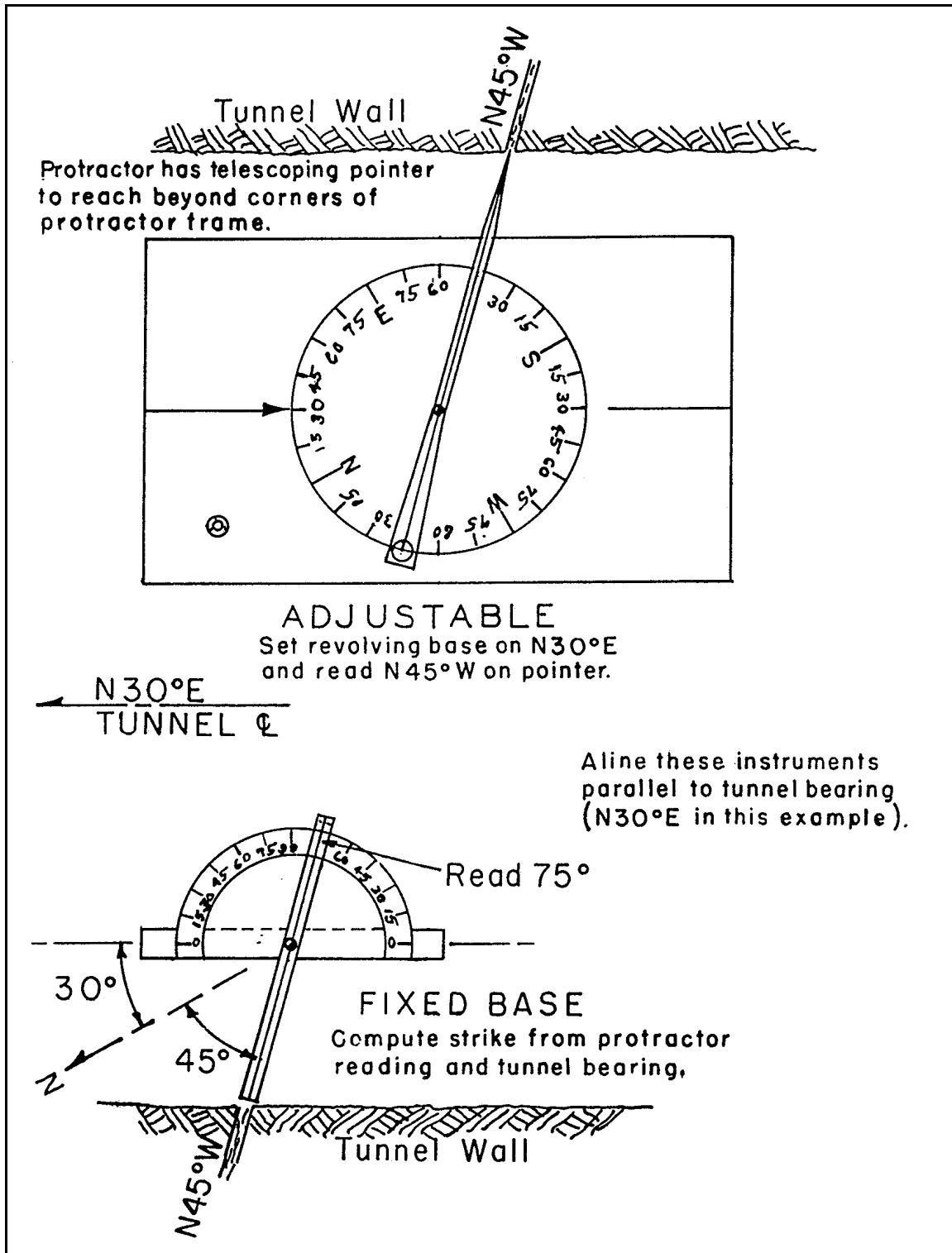

Figure C-4. Sketch of typical protractors used in peripheral geologic mapping

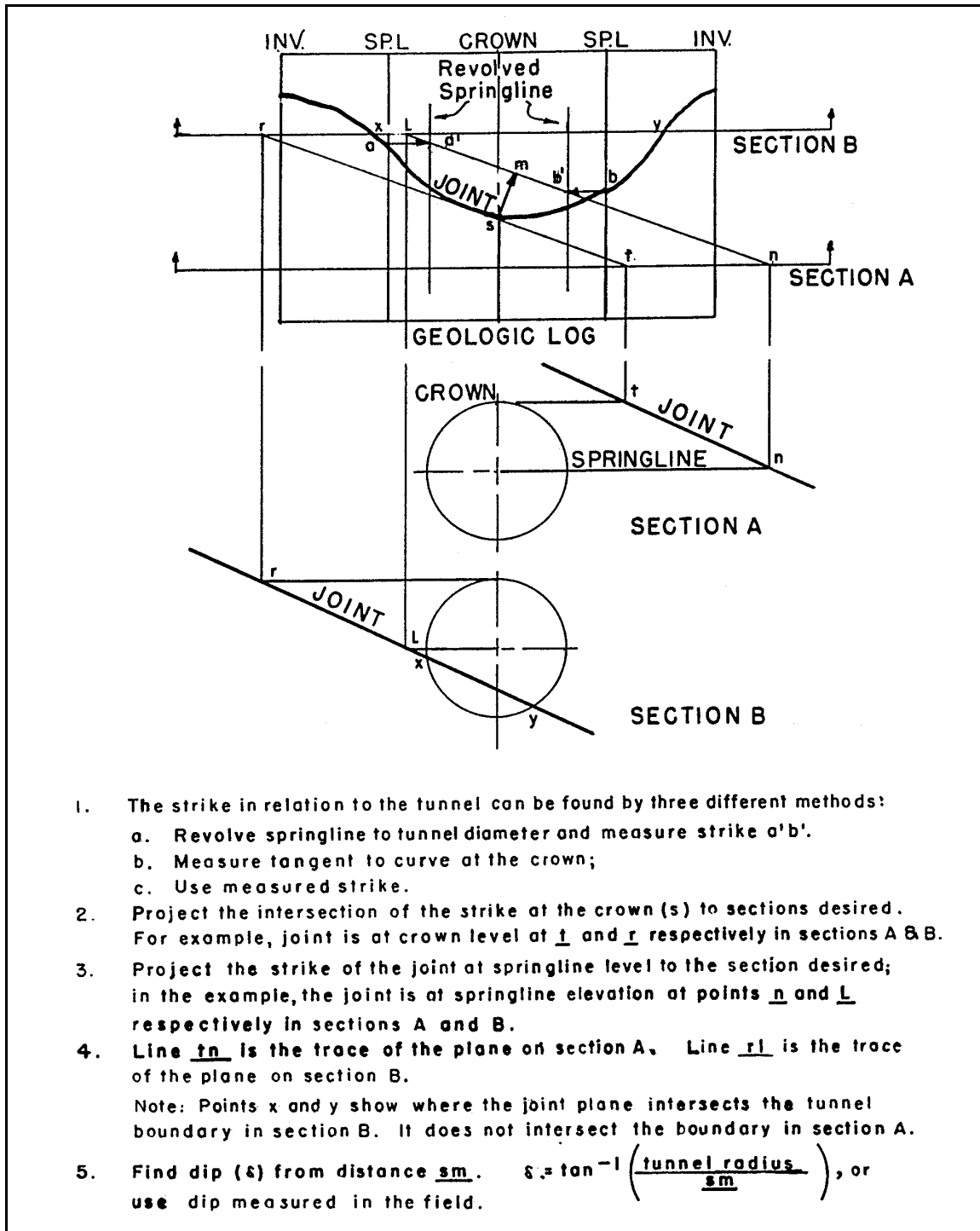

Figure C-6. Method of projecting geologic data to cross sections from geologic log as developed by R. E. Goodman, PhD, University of California

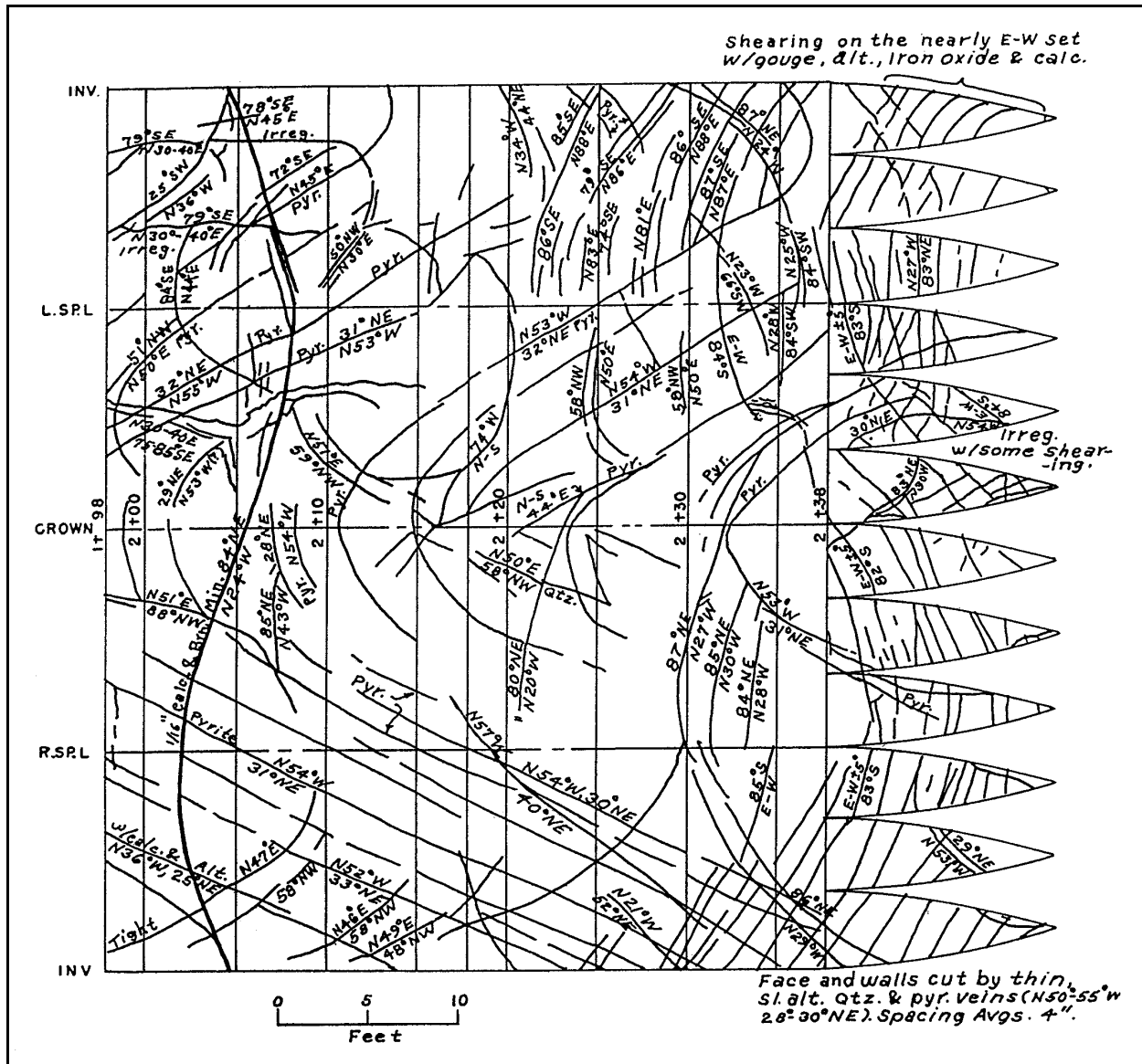

Figure C-7. Developed plan of a cylindrical drift with a hemispherical end section (in scale, 5 ft = approx. 1.5 m)

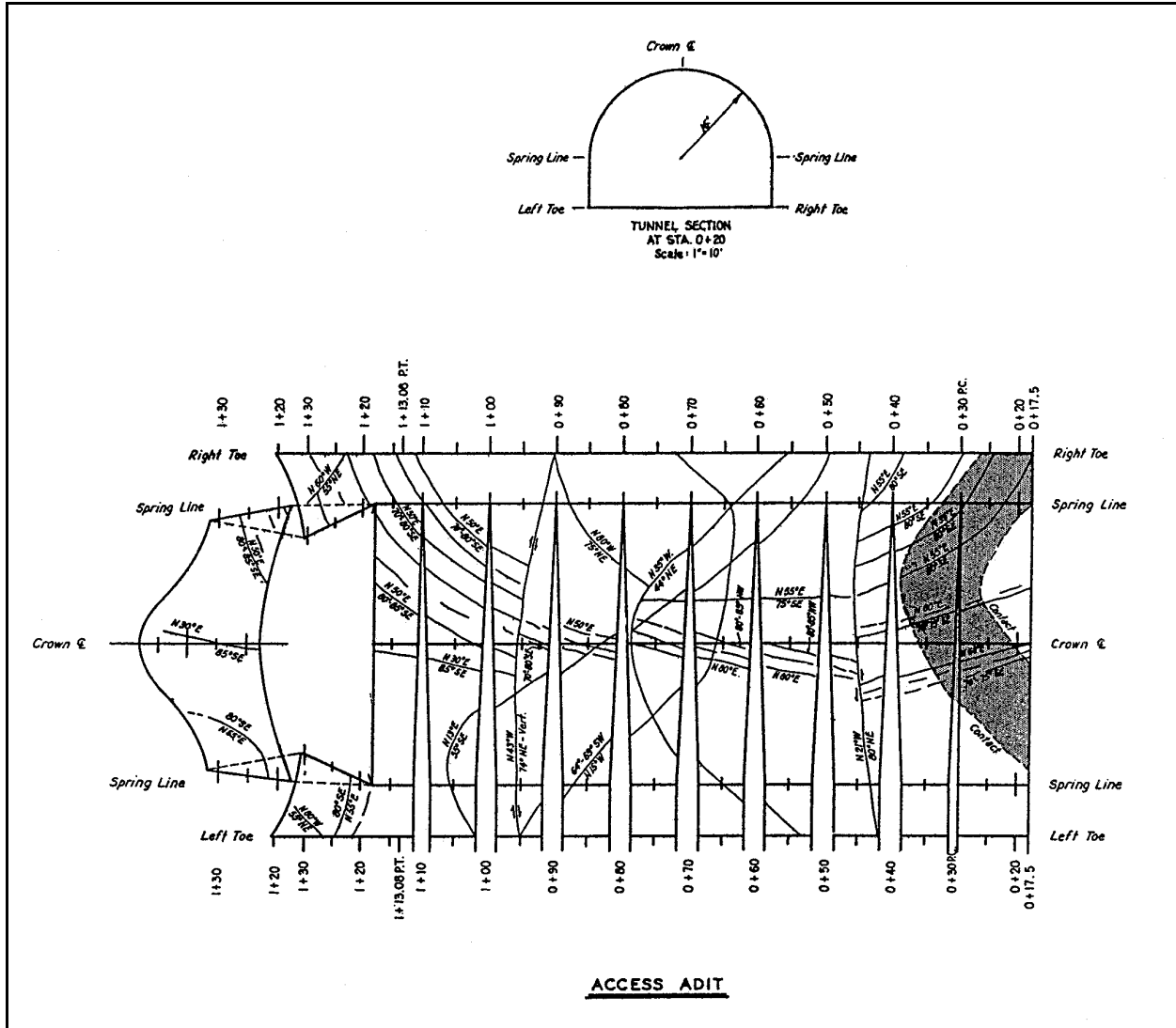

Figure C-8. Developed plan of a horseshoe-shaped drift with a curved center line and a transition to a larger drift

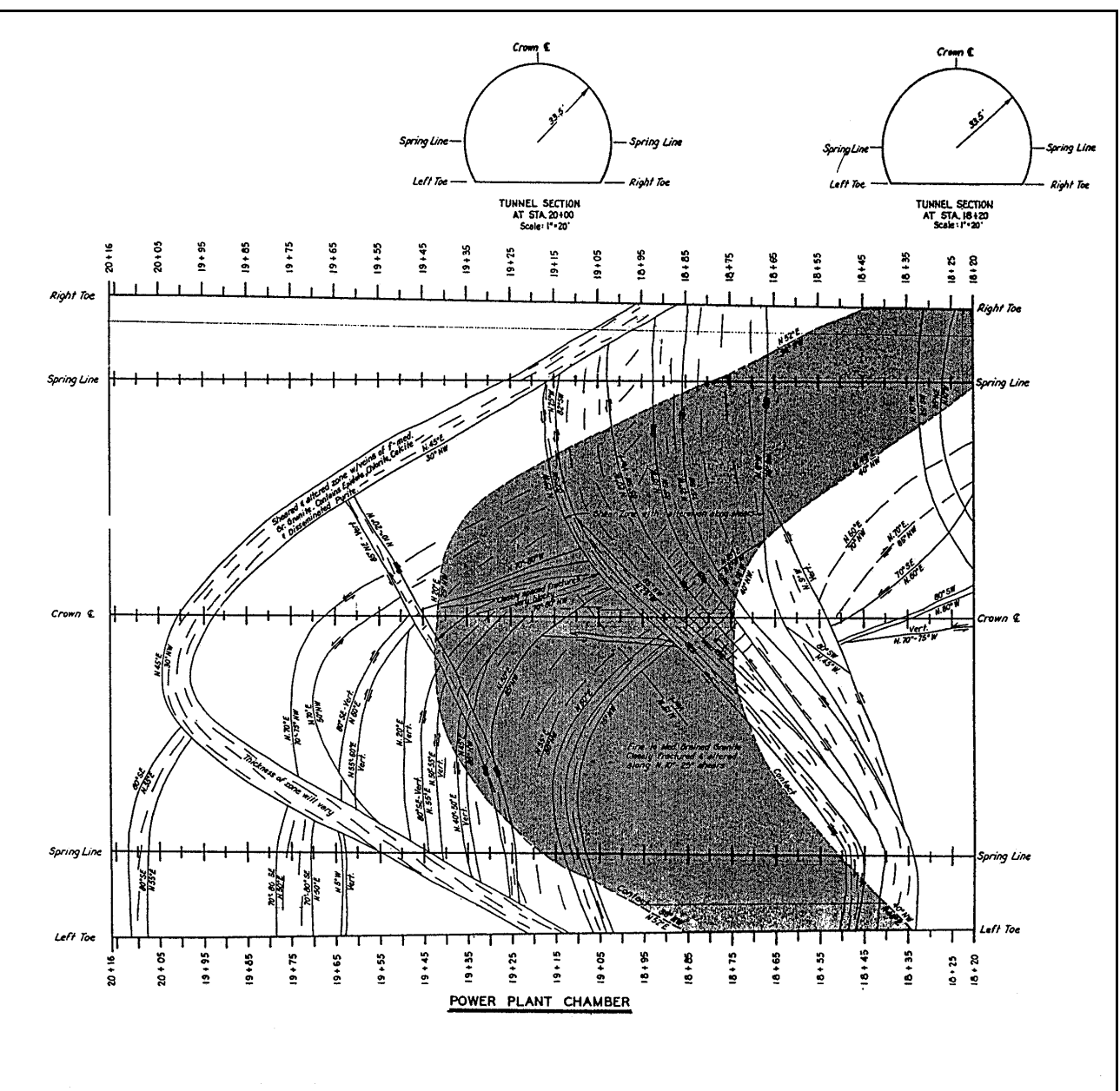

Figure C-9. Developed plan of a horseshoe-shaped large-diameter drift

Appendix D Examples of Drilling Logs

D-1. General

This appendix contains seven examples of drilling logs, five for overburden drilling, and two for rock coring. The appendix also contains examples of logs generated in the boring log data management program (BLDM) (Nash 1993). The examples are not meant to cover all possible subsurface conditions which may be encountered during field investigation but are presented to give direction to the minimum acceptable input to completing drilling logs for the most common drilling activities.

D-2. Preparation of Drilling Logs

Drilling logs should be made of each boring. A similar log will be prepared for each excavation that is constructed for the purpose of characterizing subsurface materials and geologic conditions. The only approved drilling log form for borings is ENG FORM 1836 (March 1971). This form may be used as a continuation sheet or, at the option of the user, ENG FORM 1836-A (June 1967) may be used. The PC-based, menu-driven BLDM provides a means to enter boring information directly into a computer. The BLDM can be used in the field with a laptop computer. BLDM data can be exported to the Intergraph Insight® program in which it can be printed in the ENG FORM 1836 format.

a. Scale. A scale of 1 cm = 0.25 m (1 in. = 2 ft) or larger should be used. A smaller scale may be used where, for example, the boring is advanced without sampling or logging, the upper portion of the log would represent water, or the boring was made to identify some geologic horizon such as top of rock. Other similar exceptions would be allowable.

b. Heading. All logs will have the pertinent division, installation, location, hole number, project identification, elevation, and page number entered on all log sheets. Items 1 through 19 on ENG FORM 1836 should be completed to the fullest extent possible as indicated in the seven examples. Boring numbers will be consecutive for each project. The boring numbers will be preceded by letter symbols which will identify the method of drilling. These letters are as follows:

A - Auger (Hand or Power)

C - Core

D - Drive

P - Probe

U - Undisturbed (Hydraulic or Rotary)

Additional letters and numbers for boring identification may be used at the user's discretion. Inclusion of the graphic soil symbol in column c is optional.

c. Examples. The drilling log examples of ENG FORM 1836, Figures D-1 through D-7, are described as follows:

EM 1110-1-1804
1 Jan 01

Figure D-1: Overburden, disturbed, standard penetration test, and auger.

Figure D-2: Overburden, disturbed, drive.

Figure D-3: Overburden, disturbed, auger.

Figure D-4: Overburden, undisturbed, Denison.

Figure D-5: Overburden, undisturbed, Shelby, and auger.

Figure D-6: Rock, disturbed, SPT, and core.

Figure D-7: Rock, core.

Figure D-8: Foundation boring in which geotechnical data were entered into the BLDM, exported to Intergraph Insight®, and printed in the ENG FORM 1836 format.

| DRILLING LOG | | DIVISION | | INSTALLATION | | SHEET | |
|------------------------------------------------------------------------------------------------------------------------|--|--------------------------------------------------------------------|--|-----------------------------------------------------------------|--|--------------------------------------------------------------------------------|--|
| 1. PROJECT
<i>Raymond AFB, S.C. Airmens Dorm</i> | | <i>SAD</i> | | <i>SAS</i> | | <i>1</i>
OF 2 SHEETS | |
| 2. LOCATION (Coordinates or Station)
<i>See Remarks</i> | | 10. SIZE AND TYPE OF BIT
<i>1 3/4" I.D. Split spoon</i> | | 11. DATUM FOR ELEVATION SHOWN (TBM or MSL)
<i>MSL (NVGD)</i> | | 12. MANUFACTURER'S DESIGNATION OF DRILL
<i>Failing 3/4</i> | |
| 3. DRILLING AGENCY
<i>SAS</i> | | 13. TOTAL NO. OF OVERBURDEN SAMPLES TAKEN
<i>26</i> | | 14. TOTAL NUMBER CORE BOXES
<i>-</i> | | 15. ELEVATION GROUND WATER
<i>17.5</i> | |
| 4. HOLE NO. (As shown on drawing title and file number)
<i>AD-6</i> | | 16. DATE HOLE
STARTED <i>3 Apr 81</i> COMPLETED <i>4 Apr 81</i> | | 17. ELEVATION TOP OF HOLE
<i>25.5</i> | | 18. TOTAL CORE RECOVERY FOR BORING
<i>N/A</i> | |
| 5. NAME OF DRILLER
<i>S. Long</i> | | 19. SIGNATURE OF INSPECTOR
<i>Cindy Watson</i> | | 7. THICKNESS OF OVERBURDEN
<i>30.0</i> | | 8. DEPTH DRILLED INTO ROCK
<i>0</i> | |
| 6. DIRECTION OF HOLE
<input checked="" type="checkbox"/> VERTICAL <input type="checkbox"/> INCLINED DEG. FROM VERT. | | 9. TOTAL DEPTH OF HOLE
<i>30.0</i> | | ELEVATION | | DEPTH | |
| | | | | LEGEND | | CLASSIFICATION OF MATERIALS (Description) | |
| | | | | % CORE RECOVERY | | BOX OR SAMPLE NO. | |
| | | | | | | REMARKS (Drilling time, water loss, depth of weathering, etc., if significant) | |

| ELEVATION | DEPTH | LEGEND | CLASSIFICATION OF MATERIALS (Description) | % CORE RECOVERY | BOX OR SAMPLE NO. | REMARKS (Drilling time, water loss, depth of weathering, etc., if significant) | Blow/FT |
|---------------------|-------|--------|-----------------------------------------------------------------------------------------|-----------------|-------------------|-----------------------------------------------------------------------------------------------------------------------------------------------------------|---------|
| 23.0 | 2 | | (SM) Brown, Silty SAND Roots In Top 6" | NS | 1 | <p>NS = No Sample</p> <p>LOCATION PLAN</p> <p>Encountered Water During Drilling With 5" Auger - Mixed Mud At 8' & Cleaned Boring With 4" Rock Bit</p> | 1 |
| | | | | | 2 | | 2 |
| | | | | | 3 | | 3 |
| | | | (SP-SM) Light Brown, Poorly Graded, Silty SAND, Medium To Fine, Traces Of Shell, Moist. | NS | 4 | | 4 |
| | | | | | 5 | | 5 |
| | | | | | 6 | | 6 |
| | | | (SP) Light Brown, Poorly Graded SAND, Fine w/ Traces Of Shell. | NS | 7 | | 7 |
| | | | | | 8 | | 8 |
| ▼ El 17.5
4/4/81 | 8 | | Light Gray | NS | 8 | | 8 |
| | | | | | 9 | | 9 |
| | | | | | 10 | | 10 |
| 15.5 | 10 | | (OL) Dark Gray To Black, Organic SILT, Trace Sand, Strong Odor. | NS | 11 | | 11 |
| | | | | | 12 | | 12 |
| 14.5 | 12 | | (OH) Black, Organic SILT, Lenses Of Clay, Strong Odor, Peaty. | NS | 13 | | 13 |
| | | | | | 14 | | 14 |
| 12.5 | 14 | | (SM) Dark Gray, Silty SAND, Medium To Fine. | NS | 15 | | 15 |
| | | | | | 16 | | 16 |
| 11.1 | 16 | | (SP) Light Brown, Poorly Graded SAND, Fine. | NS | 17 | | 17 |
| | | | | | 18 | 18 | |
| | | | | | 19 | 19 | |
| | | | | | 20 | 20 | |
| 7.0 | 18 | | (SP) Light Gray, Poorly Graded SAND, Medium To Coarse. | NS | 21 | 21 | |
| | | | | | 22 | 22 | |
| | | | | | 23 | 23 | |
| | | | | | 24 | 24 | |
| | | | | | 25 | 25 | |
| | | | | | 26 | 26 | |
| | | | | | 27 | 27 | |
| | | | | | 28 | 28 | |
| | | | | | 29 | 29 | |
| | | | | | 30 | 30 | |

ENG FORM 1836 MAR 71 PREVIOUS EDITIONS ARE OBSOLETE. (TRANSLUCENT) PROJECT *Raymond AFB - Airmens Dorm* HOLE NO. *AD-6*

Figure D-1. Example of Form 1836 for overburden, disturbed, SPT, and auger data (Continued)

| DRILLING LOG | | DIVISION | INSTALLATION | SHEET | | |
|-------------------------------------------------------------------------------------------------------------------|-----------|---------------------------------------------------|----------------------------------------------------------------------|--------------------------------------------|-------------------|--------------------------------------------------------------------------------|
| 1. PROJECT
<i>Raymond AFB, Airmens Dorm</i> | | <i>SAD</i> | <i>SAS</i> | OF 2 SHEETS | | |
| 2. LOCATION (Coordinates or Station) | | 10. SIZE AND TYPE OF BIT | | 11. GATUM FOR ELEVATION SHOWN (TBM or MSL) | | |
| 3. DRILLING AGENCY | | 12. MANUFACTURER'S DESIGNATION OF DRILL | | 13. TOTAL NO. OF OVER-BURDEN SAMPLES TAKEN | | |
| 4. HOLE NO. (As shown on drawing title and file number) | | 14. TOTAL NUMBER CORE BOXES | | 15. ELEVATION GROUND WATER | | |
| 5. NAME OF DRILLER | | 16. DATE HOLE | | 17. ELEVATION TOP OF HOLE | | |
| 6. DIRECTION OF HOLE
<input type="checkbox"/> VERTICAL <input type="checkbox"/> INCLINED _____ DEG. FROM VERT. | | 18. TOTAL CORE RECOVERY FOR BORING | | 19. SIGNATURE OF INSPECTOR | | |
| 7. THICKNESS OF OVERBURDEN | | 19. SIGNATURE OF INSPECTOR
<i>Cindy Watson</i> | | | | |
| 8. DEPTH DRILLED INTO ROCK | | | | | | |
| 9. TOTAL DEPTH OF HOLE | | | | | | |
| ELEVATION | DEPTH | LEGEND | CLASSIFICATION OF MATERIALS (Description) | % CORE RECOVERY | Box or SAMPLE NO. | REMARKS (Drilling time, water loss, depth of weathering, etc., if significant) |
| | | | <i>(SP) Light Gray, Poorly Graded SAND, Medium To Coarse.</i> | | <i>19</i> | <i>15</i> |
| | | | | | <i>NS</i> | <i>19</i> |
| | | | | | <i>20</i> | <i>6</i> |
| | <i>22</i> | | | | <i>NS</i> | <i>20</i> |
| | | | | | <i>21</i> | <i>25</i> |
| <i>2.0</i> | | | | | <i>22</i> | <i>10</i> |
| | <i>24</i> | | <i>Gravelly</i> | | <i>NS</i> | <i>20</i> |
| <i>1.0</i> | | | | | <i>23</i> | <i>25</i> |
| | | | <i>(CL) Brownish Gray, Sandy CLAY, Stiff To Hard, Shelly, Moist.</i> | | <i>NS</i> | <i>11</i> |
| | <i>26</i> | | | | <i>24</i> | <i>15</i> |
| | | | | | <i>NS</i> | <i>30</i> |
| | <i>28</i> | | | | <i>25</i> | <i>10</i> |
| | | | | | <i>NS</i> | <i>18</i> |
| | <i>30</i> | | | | <i>26</i> | <i>32</i> |
| <i>-4.5</i> | | | | | <i>NS</i> | <i>11</i> |
| | | | | | <i>26</i> | <i>15</i> |
| | | | | | | <i>26</i> |
| | | | <i>Bottom Of Boring</i> | | | <i>8</i> |
| | | | | | | <i>21</i> |
| | | | | | | <i>50</i> |

ENG FORM 1836 MAR 71 PREVIOUS EDITIONS ARE OBSOLETE. (TRANSLUCENT)

PROJECT *Raymond AFB, Airmens Dorm* HOLE NO. *AD-6*

Figure D-1. (Concluded)









| DRILLING LOG | | DIVISION <i>Missouri River</i> | | INSTALLATION <i>Kansas City</i> | | SHEET <i>1</i>
OF <i>5</i> SHEETS | |
|------------------------------------------------------------------------------------------------------------------------------|------------|-------------------------------------------------------------------------------------|-------------------------------------------------------|---------------------------------------------------------------|------------------------|----------------------------------------------------------------------------------------|-------------------------------|
| 1. PROJECT <i>Grove Dam</i> | | | | 10. SIZE AND TYPE OF BIT | | | |
| 2. LOCATION (Coordinates or Station)
<i>42+00 on E</i> | | | | 11. DATUM FOR ELEVATION SHOWN (TBM or MSL)
<i>NGVD</i> | | | |
| 3. DRILLING AGENCY
<i>Kansas City Dist.</i> | | | | 12. MANUFACTURER'S DESIGNATION OF DRILL
<i>Walker Neer</i> | | | |
| 4. HOLE NO. (As shown on drawing title and file number)
<i>D-18</i> | | 13. TOTAL NO. OF OVER-BURDEN SAMPLES TAKEN | | DISTURBED | | UNDISTURBED | |
| 5. NAME OF DRILLER
<i>C. Brown</i> | | 14. TOTAL NUMBER CORE BOXES | | 48 Jars | | | |
| 6. DIRECTION OF HOLE
<input checked="" type="checkbox"/> VERTICAL <input type="checkbox"/> INCLINED _____ DEG. FROM VERT. | | 15. ELEVATION GROUND WATER
<i>698.0</i> | | 16. DATE HOLE | | STARTED <i>6 Jan 78</i> COMPLETED <i>12 Jan 78</i> | |
| 7. THICKNESS OF OVERBURDEN
<i>95.0</i> | | 17. ELEVATION TOP OF HOLE
<i>715.0</i> | | 18. TOTAL CORE RECOVERY FOR BORING
<i>N/A</i> % | | | |
| 8. DEPTH DRILLED INTO ROCK
<i>0</i> | | 19. SIGNATURE OF INSPECTOR
<i>John Doe</i> | | | | | |
| 9. TOTAL DEPTH OF HOLE
<i>95.0 (EI 120.0)</i> | | | | | | | |
| ELEVATION
a | DEPTH
b | LEGEND
c | CLASSIFICATION OF MATERIALS
(Description)
d | % CORE RECOVERY
e | NON-OR SAMPLE NO.
f | REMARKS
(Drilling time, water loss, depth of weathering, etc., if significant)
g | |
| <i>714.0</i> | | | <i>Asphalt and Base Course</i> | | <i>1</i> | <i>Rec 2.0</i> | |
| | <i>2</i> |  | <i>(CL) Tan, Lean CLAY, Embankment Fill</i> | | <i>2</i> | <i>Rec 2.0</i> | <i>15 Blows</i> |
| | <i>4</i> |  | | | <i>3</i> | <i>Rec 2.0</i> | <i>16 Blows</i> |
| | <i>6</i> |  | | | <i>4</i> | <i>Rec 2.0</i> | <i>14 Blows</i> |
| | <i>8</i> |  | | | <i>5</i> | <i>Rec 2.0</i> | <i>18 Blows</i> |
| | <i>10</i> |  | | | <i>6</i> | <i>Rec 1.9
Loss 0.1</i> | <i>20 Blows</i> |
| | <i>12</i> |  | | | <i>7</i> | <i>Rec 2.0</i> | <i>14 Blows</i> |
| <i>701.0</i> | <i>14</i> |  | <i>Slightly Sandy</i> | | <i>8</i> | <i>Rec 2.0</i> | <i>18 Blows</i> |
| | <i>16</i> |  | | | <i>9</i> | <i>Rec 2.0</i> | <i>Ream to 16.0' 22 Blows</i> |
| <i>698.0 ±</i> | | | <i>Static Water Level After Completion Of Boring.</i> | | <i>10</i> | <i>Rec 1.9
Loss 0.1</i> | <i>21 Blows</i> |
| <i>12 Jan 78</i> | <i>18</i> | | | | | <i>Rec 2.0</i> | <i>23 Blows</i> |
| | <i>20</i> | | | | | | |

Figure D-2. Example of Form 1836 for overburden, disturbed, and drive data

| DRILLING LOG | | DIVISION | INSTALLATION | Hole No. A-30 | | |
|------------------------------------------------------------------------------------------------------------------------------|-------|------------------------------------------------------------|-------------------------------------------|-----------------------------------------------------------|-------------------|--------------------------------------------------------------------------------------------------------------------------------------------------------------------------------------------------------------------------------------|
| 1. PROJECT
<i>SR 9 Road Relocation Eufaula Lake</i> | | <i>SWD</i> | <i>SWT</i> | SHEET 1 OF 1 SHEETS | | |
| 2. LOCATION (Cape/Inlet or Station)
<i>Station 4+50, 50' Rt.</i> | | 10. SIZE AND TYPE OF BIT
<i>4 in. Square Auger</i> | | 11. DATUM FOR ELEVATION SHOWN (TBM or MSL)
<i>NGVD</i> | | |
| 3. DRILLING AGENCY
<i>Tulsa Dist.</i> | | 12. MANUFACTURER'S DESIGNATION OF DRILL
<i>CME-1200</i> | | 13. TOTAL NO. OF OVER-BURDEN SAMPLES TAKEN | | |
| 4. HOLE NO. (As shown on drawing title and file number)
<i>A-30</i> | | 14. TOTAL NUMBER CORE BOXES
<i>-</i> | | 15. ELEVATION GROUND WATER
<i>Not Encountered</i> | | |
| 5. NAME OF DRILLER
<i>A. Jones</i> | | 16. DATE HOLE | | 17. ELEVATION TOP OF HOLE
<i>816.2</i> | | |
| 6. DIRECTION OF HOLE
<input checked="" type="checkbox"/> VERTICAL <input type="checkbox"/> INCLINED _____ DEG. FROM VERT. | | 18. TOTAL CORE RECOVERY FOR BORING
<i>-</i> | | 19. SIGNATURE OF INSPECTOR
<i>Jane Smith</i> | | |
| 7. THICKNESS OF OVERBURDEN
<i>8.2</i> | | 19. SIGNATURE OF INSPECTOR | | | | |
| 8. DEPTH DRILLED INTO ROCK
<i>-</i> | | 8. TOTAL DEPTH OF HOLE
<i>8.2 (El 808.0)</i> | | | | |
| ELEVATION | DEPTH | LEGEND | CLASSIFICATION OF MATERIALS (Description) | % CORE RECOVERY | BOX-OR-SAMPLE NO. | REMARKS (Drilling time, water loss, depth of weathering, etc., if significant) |
| | 1 | | (CL) Brown, Sandy Lean CLAY, Moist | | | Drilled With 4 in. Square Auger. No Free Water Encountered. Refusal to Auger At 8.2', Hydraulic Pressure 100 PSI With No Penetration For 2 Min. At Refusal. Drilled 0-8' In 4 Min. Drill rate 2'/Min. Drill Action Smooth At 100 RPM |
| | 2 | | | | Jar 1 | |
| 813.2 | 3 | | (ML) Tan, Clayey, SILT, Slightly Plastic | | | |
| | 4 | | | | | |
| | 5 | | Micaceous, Slightly Damp | | Jar 2 | |
| | 6 | | | | | |
| | 7 | | | | | |
| 808.0 | 8 | | | | | |
| | 9 | | Refusal To Auger @ 8.2' | | | |

ENG FORM 1836 MAR 71 PREVIOUS EDITIONS ARE OBSOLETE. (TRANSLUCENT)

PROJECT SR9 Road Relocation Eufaula Lake HOLE NO. A-30

Figure D-3. Example of Form 1836 for overburden, disturbed, and auger data

| DRILLING LOG | | DIVISION <i>SAD</i> | | INSTALLATION <i>SAS</i> | | SHEET <i>1</i>
OF <i>1</i> SHEETS | |
|------------------------------------------------------------------------------------------------------------------------------|------------|---------------------|---------------------------------------------------|----------------------------------------------------------------|--------------------------------|--------------------------------------------------------------------------------------------------------------------------------------------------------------------------------------------------------------------------------|--|
| 1. PROJECT
<i>Richard B. Russell Dam</i> | | | | 10. SIZE AND TYPE OF BIT <i>6 in. Denison</i> | | | |
| 2. LOCATION (Coordinates or Station)
<i>X: 312,457 Y: 123,456</i> | | | | 11. DATUM FOR ELEVATION SHOWN (TBM or MSL)
<i>NGVD</i> | | | |
| 3. DRILLING AGENCY
<i>SAS</i> | | | | 12. MANUFACTURER'S DESIGNATION OF DRILL
<i>Failing 1500</i> | | | |
| 4. HOLE NO. (As shown on drawing title and file number)
<i>U-1</i> | | | | 13. TOTAL NO. OF OVER-BURDEN SAMPLES TAKEN | | DISTURBED
<i>-</i> | |
| 5. NAME OF DRILLER
<i>J. Smith</i> | | | | 14. TOTAL NUMBER CORE BOXES
<i>-</i> | | UNDISTURBED
<i>17</i> | |
| 6. DIRECTION OF HOLE
<input checked="" type="checkbox"/> VERTICAL <input type="checkbox"/> INCLINED _____ DEG. FROM VERT. | | | | 15. ELEVATION GROUND WATER <i>See Remarks</i> | | | |
| 7. THICKNESS OF OVERBURDEN
<i>36.2</i> | | | | 16. DATE HOLE | | STARTED
<i>3-16-75</i> | |
| 8. DEPTH DRILLED INTO ROCK
<i>0</i> | | | | 17. ELEVATION TOP OF HOLE
<i>376.5</i> | | COMPLETED
<i>3-16-75</i> | |
| 9. TOTAL DEPTH OF HOLE <i>36.2 (EI 340.3)</i> | | | | 18. TOTAL CORE RECOVERY FOR BORING <i>N/A</i> % | | | |
| | | | | 19. SIGNATURE OF INSPECTOR
<i>Johnny Jones</i> | | | |
| ELEVATION
a | DEPTH
b | LEGEND
c | CLASSIFICATION OF MATERIALS
(Description)
d | % CORE RECOVERY
e | BOX OR SAMPLE NO.
f | REMARKS
(Drilling time, water loss, depth of weathering, etc., if significant)
g | |
| | 5 | | <i>(ML) Reddish Brown, Slightly Clayey, SILT.</i> | <i>HAND</i> | | <i>Fish Tailed To 2'. Drilled With 6 in. Denison Barrel With Inner Barrel Protruding 1 in. 100% Recovery Except As Noted. Hand Penitrometer Made On Bottom Of Each Sample. No Changes In Drill Mud To Indicate Free Water.</i> | |
| | 10 | | | <i>PENE</i> | <i>1</i> | | |
| | 15 | | | <i>TSF</i> | <i>2</i> | | |
| | 20 | | | | <i>3</i> | | |
| | 25 | | | | <i>4</i> | | |
| | 30 | | <i>Red, Slightly Sandy</i> | | <i>5</i> | <i>#6 Ran 2.0
Rec 1.6</i> | |
| | 35 | | | | <i>6</i> | | |
| | | | | | <i>7</i> | | |
| | | | | | <i>8</i> | | |
| | | | | | <i>9</i> | | |
| | | | <i>Bottom Of Hole</i> | | <i>10</i> | <i>#10 Ran 2.0
Rec 1.8</i> | |
| | | | | | <i>11</i> | | |
| | | | | | <i>12</i> | | |
| | | | | | <i>13</i> | | |
| | | | | | <i>14</i> | | |
| | | | | <i>15</i> | <i>#14 Ran 2.0
Rec 1.2</i> | | |
| | | | | <i>16</i> | | | |
| | | | | <i>17</i> | | | |
| <i>340.3</i> | <i>35</i> | | | | | <i>Refusal At 36.2'
No Recovery 36.0'-36.2'</i> | |

ENG FORM 1836 MAR 71 PREVIOUS EDITIONS ARE OBSOLETE.
(TRANSLUCENT)

PROJECT *Richard B. Russell Dam* HOLE NO. *U-1*

Figure D-4. Example of Form 1836 for overburden, undisturbed, and Denison data

| DRILLING LOG | | DIVISION | INSTALLATION | Hole No. <i>AU-3</i> | | |
|------------------------------------------------------------------------------------------------------------------------------|------------|-------------|--------------------------------------------------------------------------------------------------------------------|----------------------------------------------------------------------------------------|------------------------|-----------------------------------------------------------------------------------------------------------------------------------------------------------------------------------------------------------------------------------|
| 1. PROJECT
<i>Alum Creek Dam, Ohio</i> | | <i>ORD</i> | <i>Huntington</i> | SHEET <i>1</i>
OF <i>1</i> SHEETS | | |
| 2. LOCATION (Coordinates or Station)
<i>Sta. 2+50.0 5 d/s of E</i> | | | 10. SIZE AND TYPE OF BIT
<i>6 in. Auger & 5 in. Shelby</i> | 11. DATUM FOR ELEVATION SHOWN (TBM or MSL)
<i>NGVD</i> | | |
| 3. DRILLING AGENCY
<i>ORH</i> | | | 12. MANUFACTURER'S DESIGNATION OF DRILL
<i>Falling 1500</i> | 13. TOTAL NO. OF OVERBURDEN SAMPLES TAKEN
DISTURBED: <i>-</i> UNDISTURBED: <i>3</i> | | |
| 4. HOLE NO. (As shown on drawing title and file number)
<i>AU-3</i> | | | 14. TOTAL NUMBER CORE BOXES
<i>-</i> | 15. ELEVATION GROUND WATER
<i>Not Encountered</i> | | |
| 5. NAME OF DRILLER
<i>C. Black</i> | | | 16. DATE HOLE STARTED
<i>6 May 1981</i> | COMPLETED
<i>6 May 1981</i> | | |
| 6. DIRECTION OF HOLE
<input checked="" type="checkbox"/> VERTICAL <input type="checkbox"/> INCLINED _____ DEG. FROM VERT. | | | 17. ELEVATION TOP OF HOLE
<i>952.4</i> | 18. TOTAL CORE RECOVERY FOR BORING
<i>N/A</i> % | | |
| 7. THICKNESS OF OVERBURDEN
<i>-</i> | | | 19. SIGNATURE OF INSPECTOR
<i>William Boyd</i> | | | |
| 8. DEPTH DRILLED INTO ROCK
<i>-</i> | | | 9. TOTAL DEPTH OF HOLE
<i>22.0 (El. 930.4)</i> | | | |
| ELEVATION
a | DEPTH
b | LEGEND
c | CLASSIFICATION OF MATERIALS
(Description)
d | % CORE RECOVERY
e | BOX OR SAMPLE NO.
f | REMARKS
(Drilling time, water loss, depth of weathering, etc., if significant)
g |
| | 5 | | | | | <i>Augered w/ 6 in. Helical Auger To 6, 10, And 20 Feet. Where 5 in. Shelby Tubes Were Pushed 24 in. Hand Penetrometer Taken On Lower End Of Each Sample Push 1 Ran 24" Rec 24" Push 2 Ran 24" Rec 24" Push 3 Ran 24" Rec 24"</i> |
| | 10 | | | <i>1.0</i> | <i>U-1</i> | |
| | 15 | | | <i>1.6</i> | <i>U-2</i> | |
| | 20 | | | <i>2.0</i> | <i>U-3</i> | |
| <i>930.4</i> | | | <i>Bottom Of Boring</i> | | | |
| | | | <i>Note. Description Of Materials Should Be Entered Into Column d Only After Completion Of Laboratory Testing.</i> | | | |

NG FORM 1836
MAR 71

PREVIOUS EDITIONS ARE OBSOLETE.
(TRANSLUCENT)

PROJECT

Alum Creek Dam, Ohio

HOLE NO.

AU-3

Figure D-5. Example of Form 1836 for overburden, undisturbed, Shelby, and auger data

| DRILLING LOG | | DIVISION <i>South Pacific</i> | | INSTALLATION <i>Los Angeles</i> | | Hole No. <i>DC-4</i> | |
|------------------------------------------------------------------------------------------------------------------------------|------------|----------------------------------------------------------|-------------------------------------------------------------------------------------------------------------------------|------------------------------------------------------------------|------------------------|---------------------------------------------------------------------------------------------------------------------------------------------|--|
| 1. PROJECT <i>PRADO DAM, CA.</i> | | 10. SIZE AND TYPE OF BIT <i>Diamond NWM</i> | | SHEET <i>1</i> | | OF <i>42</i> SHEETS | |
| 2. LOCATION (Coordinates of Station)
<i>See Remarks</i> | | 11. DATUM FOR ELEVATION SHOWN (FSM or MSL)
<i>MSL</i> | | 12. MANUFACTURER'S DESIGNATION OF DRILL
<i>Sullivan - 180</i> | | | |
| 3. DRILLING AGENCY
<i>Mott Drilling Co.</i> | | 13. TOTAL NO. OF OVER-BURDEN SAMPLES TAKEN | | DISTURBED <i>4</i> | | UNDISTURBED | |
| 4. HOLE NO. (As shown on drawing title and file number)
<i>DC-4</i> | | 14. TOTAL NUMBER CORE BOXES
<i>14</i> | | 15. ELEVATION GROUND WATER
<i>See Remarks</i> | | | |
| 5. NAME OF DRILLER
<i>Horton</i> | | 16. DATE HOLE | | STARTED <i>2/18/79</i> | | COMPLETED <i>3/18/79</i> | |
| 6. DIRECTION OF HOLE
<input checked="" type="checkbox"/> VERTICAL <input type="checkbox"/> INCLINED _____ DEG. FROM VERT. | | 17. ELEVATION TOP OF HOLE
<i>575.0</i> | | 18. TOTAL CORE RECOVERY FOR BORING <i>99.4/99.5 %</i> | | | |
| 7. THICKNESS OF OVERBURDEN <i>5.0 (575.0)</i> | | 19. SIGNATURE OF INSPECTOR
<i>Jim Jones</i> | | | | | |
| 8. DEPTH DRILLED INTO ROCK
<i>100.0</i> | | | | | | | |
| 9. TOTAL DEPTH OF HOLE
<i>475.0</i> | | | | | | | |
| ELEVATION
a | DEPTH
b | LEGEND
c | CLASSIFICATION OF MATERIALS
(Description)
d | % CORE RECOVERY
e | BOX OR SAMPLE NO.
f | REMARKS
(Drilling time, water loss, depth of weathering, etc., if significant)
g | |
| 573.5 | 1 | | (CL) Brown, Sandy CLAY, Roots In Top 6", Moist. | | 1 | Brown's Store → Hwy 36
↓ 50' 15"
 Aprax 3500' C-4 | |
| | 2 | | (SC) Brown, Clayey, SAND, Fine To Medium, Moist | | 2 | Drl w/ 1.1' x 4 1/2" Roller Rock Bit w/ Water
Begin 1300 19
End 1350 | |
| | 3 | | | | 3 | Ran 5.0'
Set 5.3' of 4" Black Iron Pipe w/ Saw Tooth End To 5.0' 22 | |
| 570.5 | 4 | | Rock Frags | | 4 | Ref At 5.0' 50 | |
| 570.0 | 5 | | TR | | | | |
| | 6 | | SANDSTONE - Mss Bdd, Sl, Mic, Med Hd To Hd, F To Med Gra, It Gr To Lt Br, Occ Bk Sh Pths, Num Hem Pths Upper 3' Of Core | Rec 84% | Box 1 | Drl w/ 11.7 (10.3) NXM Bit # 1234 (V. Good)
Shell # 5678 (New)
Pull 1 | |
| | 7 | | So To Med Hd, V.F. 0.6 LC | | 10 | Drl Tools 21.7' WL 7.6' @ 1640
Began 1615
End 1635 | |
| | 8 | | So, St Red | RQD 79% | Boxes | Drl Time 20 Min
Ran 5.2
Rec 3.8
Loss 1.4
U.L. 0.6
Water Pressure 50 psi
Drl Action - Smooth
100% DWR - 100%
CD 9.4' | |
| | 9 | | Op, 1/4 Jt, 55° | | | Tape
RQD 3.5' = 0.79%
4.4' | |
| | 10 | | | | | | |

Figure D-6. Example of Form 1836 for bedrock, disturbed, SPT, and core data (Continued)

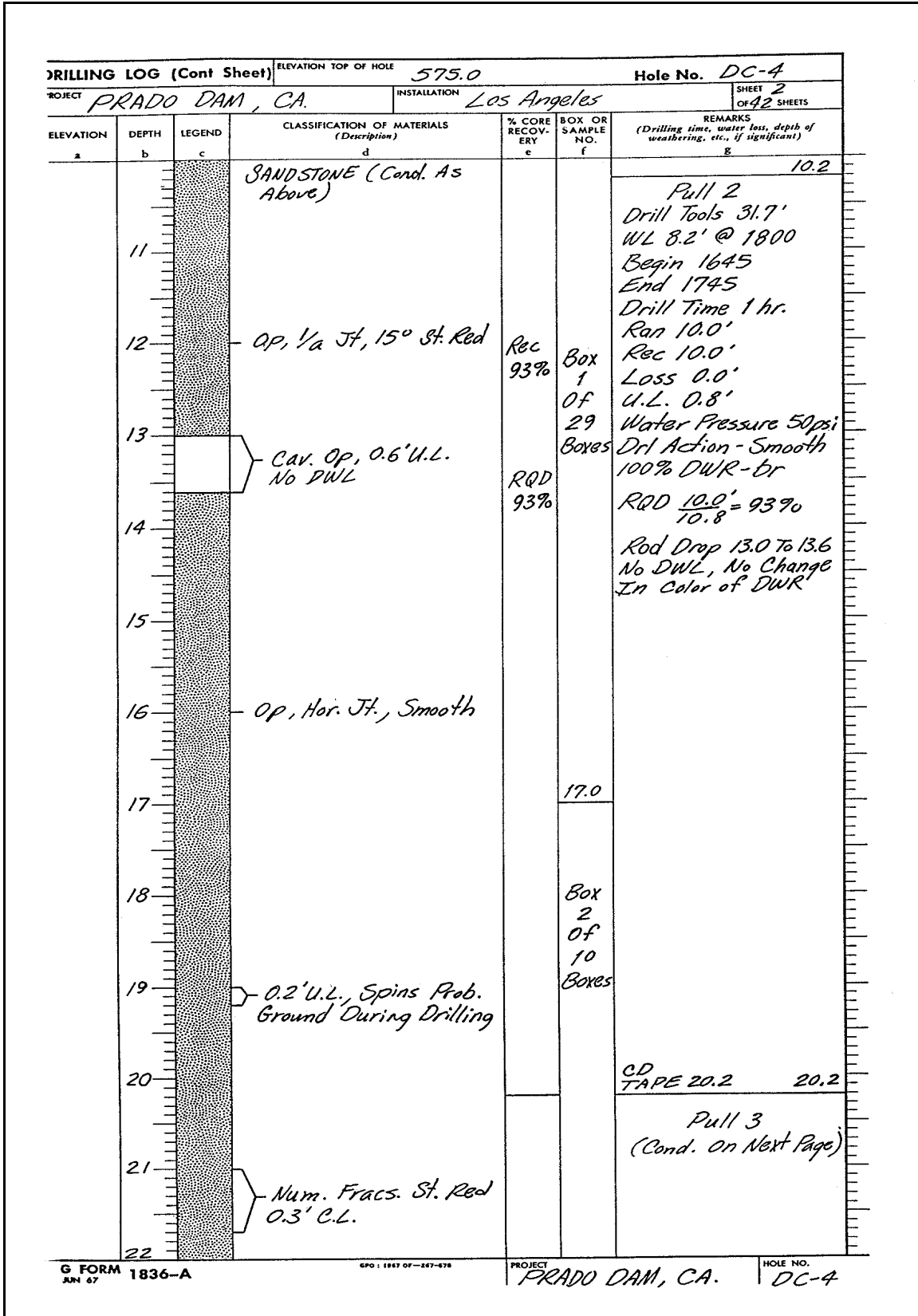

Figure D-6. (Concluded)

| DRILLING LOG | | DIVISION | INSTALLATION | Hole No. C-18 | | SHEET 1 OF 3 SHEETS |
|------------------------------------------------------------------------------------------------------------------------------|------------|-------------------|-----------------------------------------------------------------------------------------------------------------------------------------------------------------------------------|---------------------------------------------------------------|------------------------|----------------------------------------------------------------------------------------------------------------------------------------|
| 1. PROJECT
<i>Taylorville Dam</i> | | <i>Ohio River</i> | <i>Louisville</i> | 10. SIZE AND TYPE OF BIT
<i>Dia NWA</i> | | |
| 2. LOCATION (Coordinates or Station)
<i>X: 137,187 F Y: 26,867 F</i> | | | | 11. DATUM FOR ELEVATION SHOWN (TBM or MSL)
<i>MSL</i> | | |
| 3. DRILLING AGENCY
<i>Louisville District</i> | | | | 12. MANUFACTURER'S DESIGNATION OF DRILL
<i>Failing 314</i> | | |
| 4. HOLE NO. (As shown on drawing title and file number)
<i>C-18</i> | | | | 13. TOTAL NO. OF OVER-BURDEN SAMPLES TAKEN | | DISTURBED
—
UNDISTURBED
— |
| 5. NAME OF DRILLER
<i>A. Brown</i> | | | | 14. TOTAL NUMBER CORE BOXES
<i>4</i> | | |
| 6. DIRECTION OF HOLE
<input checked="" type="checkbox"/> VERTICAL <input type="checkbox"/> INCLINED _____ DEG. FROM VERT. | | | | 15. ELEVATION GROUND WATER
<i>606.5</i> | | |
| 7. THICKNESS OF OVERBURDEN
<i>0</i> | | | | 16. DATE HOLE | | STARTED
<i>11 Aug 76</i>
COMPLETED
<i>16 Aug 76</i> |
| 8. DEPTH DRILLED INTO ROCK
<i>33.5</i> | | | | 17. ELEVATION TOP OF HOLE
<i>625.5</i> | | |
| 9. TOTAL DEPTH OF HOLE
<i>33.5' (EL 592.0)</i> | | | | 18. TOTAL CORE RECOVERY FOR BORING
<i>93 %</i> | | |
| | | | | 19. SIGNATURE OF INSPECTOR
<i>John Smith</i> | | |
| ELEVATION
a | DEPTH
b | LEGEND
c | CLASSIFICATION OF MATERIALS
(Description)
d | % CORE RECOVERY
e | BOX OR SAMPLE NO.
f | REMARKS
(Drilling time, water loss, depth of weathering, etc., if significant)
g |
| | 1 | | LIMESTONE, Silty, Hard Slightly Weathered To Unweathered, Finely Crystalline, Massively Bedded, Moderately Jointed w/ Tight, Smooth Bedding Plane Joints Dipping 5°, Gray, Vuggy. | Rec 100% | Box 1 of 4 Boxes | Bit # 1234 - New
Shoe # 456 - Used, Good
5.0' Barrell
Pull 1 0-4.5'
Ran 4.5
Rec 4.5
Loss 0.0 |
| | 2 | | Moderately Weathered, Tan | RQD 100% | | Drl. Action Smooth
Water Return - 100%
Lt. Gray
Hyd Press. 100 psi
Drill Time 32 min.

RQD $\frac{4.5'}{4.5'} = 100$ |
| | 3 | | Tight High Angle Joints | | | |
| | 4 | | | | | C.D. 4.5 4.5 |
| | 5 | | | | | Pull 2
4.5-9.5 |
| | 6 | | Horizontal Joint, Rough Slightly Open | Rec 91% | | Ran 5.0
Rec 4.2
Loss 0.8
U.L. 0.4 |
| | 7 | | Dark Gray, Very Silty | RQD 85% | | Drl Action - Rough
7.0'-7.7'
Water Return 100%
Reddish Brown
7.0'-9.5' |
| | 8 | | Shattered, Stained Red-Brown, Trace Of Red Clay, 0.4' U.L. | | | Drl Time 48 min
Hyd Press. 150 psi

RQD $\frac{3'11''}{4'7''} = 85\%$ |
| | 9 | | 45° Joint, Tight, Smooth | | 9.1' | CD Tape 9.1 |
| | 10 | | | | | 9.5 |

Figure D-7. Example of Form 1836 for bedrock and core data (Sheet 1 of 3)

| DRILLING LOG (Cont Sheet) | | ELEVATION TOP OF HOLE 625.5 | | Hole No. C-18 | | |
|---------------------------|-------|-----------------------------|----------------------------------------------------------------------------------------|-----------------|---------------------|-------------------------------------------------------------------------------------------------------------------------------------------------------------|
| PROJECT Taylorsville Dam | | | INSTALLATION Louisville | | SHEET 2 OF 3 SHEETS | |
| ELEVATION | DEPTH | LEGEND | CLASSIFICATION OF MATERIALS (Description) | % CORE RECOVERY | BOX OR SAMPLE NO. | REMARKS (Drilling time, water loss, depth of weathering, etc., if significant) |
| a | b | c | d | e | f | g |
| | 10 | | LIMESTONE (Cont.) | | | Pull 3
9.5 - 14.0 |
| | 11 | | Numerous Vugs | Rec 100% | Box 2 Of 4 Boxes | Ran 4.5
Rec 4.9
Gain 0.4
Drl. Action Smooth
Water Ret. 100% Gray |
| | 12 | | Horizontal Open Joints | RQD 71% | | Drl. Time 62 min.
Hyd. Press. 150 psi
RQD $\frac{3'6''}{4'11''} = 71\%$ |
| | 13 | | Core Badly Broken Numerous Closely Spaced High Angle And Horizontal Joints | | | |
| | 14 | | Low Angle (10°) Irregular Joint, Tight
45° Joint, Tight
45° Joint, Slightly Open | | | CD 14.0 14.0 |
| | 15 | | | Rec 100% | | Pull 4
14.0 - 19.0
Ran 5.0
Rec 4.5
Loss 0.5
U.L. 0.0
Drl. Action Smooth
Water Ret. 100% Gray |
| | 16 | | | RQD 85% | | Drl. Time 75 min.
Hyd. Press. 150 psi
RQD $\frac{3'9''}{4'5''} = 85\%$ |
| | 17 | | | | | |
| | 18 | | Irregular, Horizontal Joint, Tight | | 18.0 | CD TAPE 18.5 |
| 306.4 | 19 | | 100% Drill Water Loss | | | 19.0 |
| | 20 | | Open Cavity, Tools Dropped Freely | Rec 61% | Box 3 Of 4 Boxes | Pull 5
19.0 - 25.5
Ran 6.5
Rec 4.0
Loss 2.5
U.L. 2.6
Drl. Action - Rough
100% W.L. At 19.1
Drl. Time 40 min.
Hyd. Press. 150 psi |
| 304.3 | 21 | | Stained Brown | RQD 53% | | |
| | 22 | | | | | |

Figure D-7. (Sheet 2 of 3)

| DRILLING LOG (Cont Sheet) | | ELEVATION TOP OF HOLE 625.5 | | Hole No. C-18 | | |
|---------------------------|-------|-----------------------------|-------------------------------------------|-----------------|--------------------|---------------------------------------------------------------------------------------------------------------------------------|
| PROJECT Taylorsville Dam | | | INSTALLATION Louisville | | | |
| ELEVATION | DEPTH | LEGEND | CLASSIFICATION OF MATERIALS (Description) | % CORE RECOVERY | BOX OR SAMPLE NO. | REMARKS (Drilling time, water loss, depth of weathering, etc., if significant) |
| a | b | c | d | e | f | R |
| | 22 | | LIMESTONE (Cont.) | | | Pull 5 (Cont.) |
| | 23 | | Horizontal Open Joints Stained Brown | Rec 61% | Box 3 | RQD $\frac{3'6''}{6'7''} = 53\%$ |
| | 24 | | | RQD 53% | of 4 Boxes (Cont.) | W.L. In Hole After Run 19.0' |
| | 25 | | Fresh, Irregular Break Near Horizontal | | | CD Tape 25.1 |
| | 26 | | | Rec 100% | | Pull 6 25.5-29.0 |
| | 27 | | Fresh Break Along Silty Parting | RQD 100% | 27.0 | Ran 3.5
Rec 3.9
Gain 0.4
Drl. Action Rough
No D.W. Return
Hyd. Press. 150 psi
Drl Time 40 min.
W.L. -19.0' |
| | 28 | | | | Box 4 of 4 | RQD $\frac{3'11''}{3'11''} = 100\%$ |
| | 29 | | 45° Joint, Tight, Smooth | | Boxes | CD 29.0 |
| | 30 | | | Rec 100% | | Pull 7 29.0-33.5 |
| | 31 | | | RQD 100% | | Ran 4.5
Rec 4.5
Loss 0.0
Drl. Action Rough
No D.W. Return
Hyd. Press. 150 psi
Drl. Time 70 min.
W.L. 19.0' |
| | 32 | | Horizontal Fracture Irregular, Fr. sh | | | RQD $\frac{4'6''}{4'6''} = 100\%$ |
| | 33 | | | | | Water Level 19.0' After 24 Hr. |
| 592.0 | | | Bottom of Hole | | | Tape CD 33.5 |

Figure D-7. (Sheet 3 of 3)

| DRILLING LOG | | DIVISION | | INSTALLATION | | SHEET 1
OF 2 SHEETS | |
|-------------------------------------------------------------------------------------------------------------------|------------|-------------|---------------------------------------------------|--------------------------------------------|------------------------|---------------------------------------------------------------------------------------|--|
| 1. PROJECT Waterways Experiment Station | | | | 10. SIZE AND TYPE OF BIT | | | |
| 2. LOCATION (Coordinates or Station) 650287.0000 337262.0000 | | | | 11. DATUM FOR ELEVATION SHOWN (BM or MSL) | | | |
| 3. DRILLING AGENCY | | | | 12. MANUFACTURER'S DESIGNATION OF DRILL | | | |
| 4. HOLE NO. (As shown on drawing title and file number) 3396-U-5 | | | | 13. TOTAL NO. OF OVER-BURDEN SAMPLES TAKEN | | DISTURBED UNDISTURBED | |
| 5. NAME OF DRILLER | | | | 14. TOTAL NUMBER CORE BOXES | | | |
| 6. DIRECTION OF HOLE
<input type="checkbox"/> VERTICAL <input type="checkbox"/> INCLINED _____ DEG. FROM VERT. | | | | 15. ELEVATION GROUND WATER | | | |
| 7. THICKNESS OF OVERBURDEN | | | | 16. DATE HOLE | | STARTED 8/25/1975 COMPLETED 8/25/1975 | |
| 8. DEPTH DRILLED INTO ROCK | | | | 17. ELEVATION TOP OF HOLE 193.40 | | | |
| 9. TOTAL DEPTH OF HOLE 146.10 | | | | 18. TOTAL CORE RECOVERY FOR BORING % | | | |
| | | | | 19. SIGNATURE OF INSPECTOR | | | |
| ELEVATION
a | DEPTH
b | LEGEND
c | CLASSIFICATION OF MATERIALS
(Description)
d | % CORE RECOVERY
e | BOX OR SAMPLE NO.
f | REMARKS
(Drilling time, water loss, depth of weathering, etc. if significant)
g | |
| | 5 | | Lean, sandy, silty clay, med plasticity CL | | | | |
| | 10 | | | | | | |
| | 15 | | Silt, very fine sand, clayey fine sand ML | | | | |
| | 20 | | | | | | |
| | 25 | | | | | | |
| | 30 | | No Data ND | | | | |
| | 35 | | Silt, very fine sand, clayey fine sand ML | | | | |
| | 40 | | | | | | |
| | 45 | | Lean, sandy, silty clay, med plasticity CL | | | | |

ENG FORM 1836 PREVIOUS EDITIONS ARE OBSOLETE. MAR 71

PROJECT _____ HOLE NO. _____

Figure D-8. Foundation boring in which geotechnical data were entered into the BLDM, exported to Intergraph Insight, and printed in the ENG FORM 1836 format (Continued)

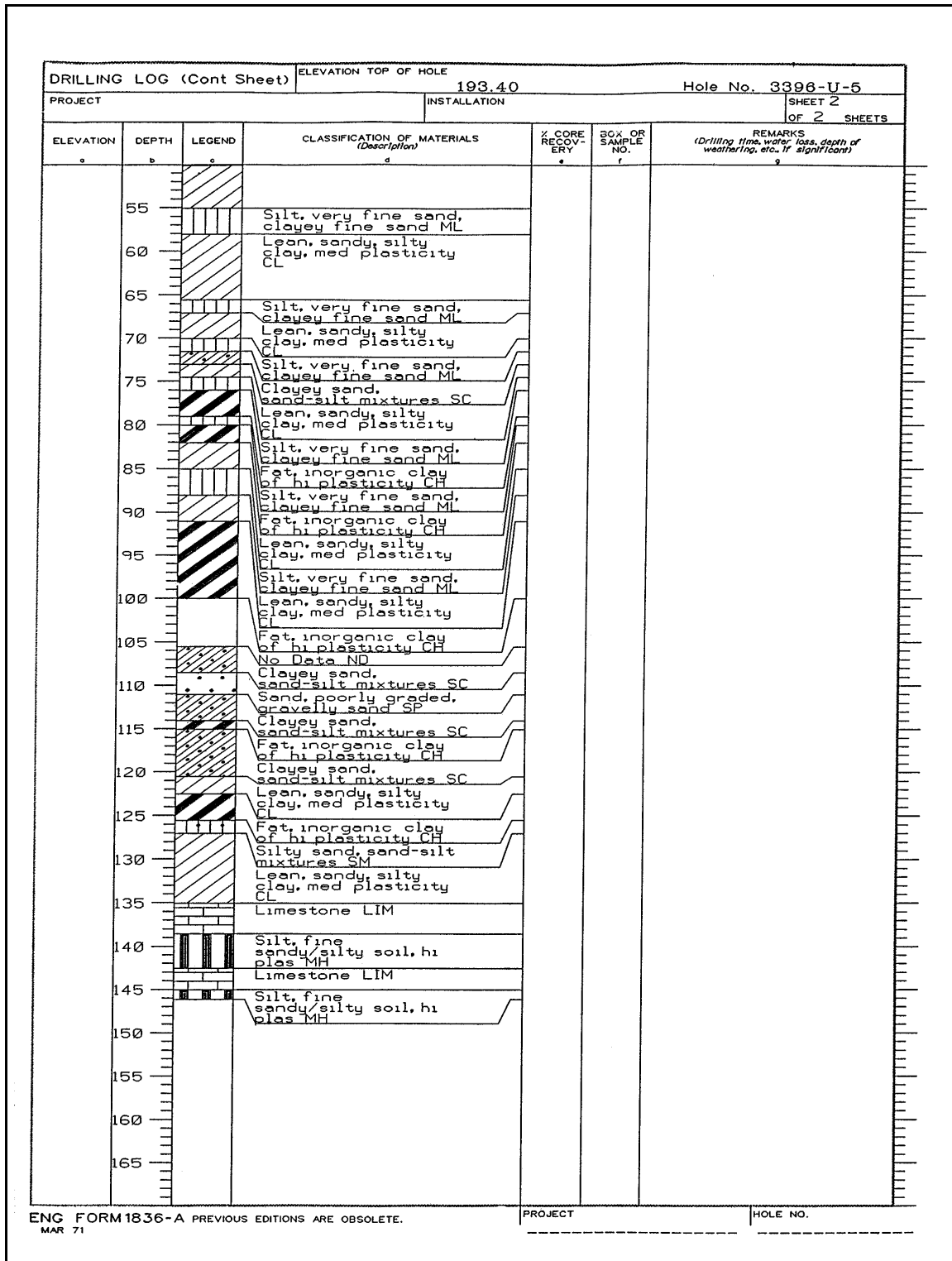

Figure D-8. (Concluded)

Appendix E List of Acronyms

| | |
|-------|-------------------------------------------------|
| AR | Army Regulation |
| ASTM | American Society for Testing Material |
| BLDM | Boring Log Data Manager |
| CADD | Computer aided design and drafting |
| CEWES | Corps of Engineers Waterways Experiment Station |
| COE | Corps of Engineers |
| CPT | Cone Penetrometer Test |
| D | Diameter |
| DOD | Department of Defense |
| DTM | Digital Terrain Model |
| EM | Engineer Manual |
| EP | Engineer Pamphlet |
| ER | Engineer Regulation |
| ETL | Engineer Technical Letter |
| ft | feet |
| GDM | General Design Memorandum |
| GIS | Geographic Information System |
| GPS | Global Positioning System |
| GPR | Ground Penetrating Radar |
| HTRW | Hazardous Toxic and Radioactive Waste |
| ID | Inside diameter |
| in | inch(es) |
| MACOM | Major Area Command |
| MCA | Military Construction Army |
| min | minute |
| MOU | Memorandum of understanding |

| | |
|-------|--------------------------------------------------------|
| NOAA | National Oceanic and Atmospheric Administration |
| OCR | Overconsolidation ratio |
| OD | Outside diameter |
| PC | Personal Computer |
| PDB | Project Development Brochures |
| PED | Preconstruction Engineering and Design |
| RQD | Rock Quality Designation |
| ROV | Remotely operated vehicle |
| RTH | Rock Testing Handbook |
| SAR | Satellite Synthetic Aperture Radar |
| SCAPS | Site Characterization and Analysis Penetrometer System |
| SLAR | Side Looking Airborne Radar |
| SPT | Standard Penetration Test |
| TM | Technical Manual |
| U.S. | United States |
| USCS | Unified Soil Classification System |
| USDA | United States Department of Agriculture |
| USGS | United States Geological Survey |
| WES | Waterways Experiment Station |

**APPENDIX F
SOIL SAMPLING**

Table of Contents

| Subject | Paragraph
(F) | Page
(F-) |
|-------------------------------------------------------------------------|------------------|--------------|
| Chapter F-1 | | |
| Introduction | | |
| Purpose | 1-1 | 1-1 |
| Applicability | 1-2 | 1-1 |
| References | 1-3 | 1-1 |
| Rescission | 1-4 | 1-1 |
| Background | 1-5 | 1-1 |
| Organization and Scope | 1-6 | 1-2 |
|
 | | |
| Chapter F-2 | | |
| Sampling Requirements | | |
| Introduction | 2-1 | 2-1 |
| Sample Quality | 2-2 | 2-2 |
| Parameters Which Affect Sample Disturbance | 2-3 | 2-2 |
| Selection of Sampling Apparatus to Obtain Undisturbed Samples | 2-4 | 2-5 |
| Borehole Layout, Depth and Interval of Sampling, and Sample Diameter .. | 2-5 | 2-9 |
|
 | | |
| Chapter F-3 | | |
| Drill Rigs and Appurtenant Equipment | | |
| Introduction | 3-1 | 3-1 |
| Drill Rigs | 3-2 | 3-1 |
| Types of Drills | 3-3 | 3-5 |
| Accessories and Appurtenant Equipment | 3-4 | 3-10 |
|
 | | |
| Chapter F-4 | | |
| Drilling Fluids | | |
| Purpose of Drilling Fluids | 4-1 | 4-1 |
| Types of Drilling Fluids | 4-2 | 4-1 |
| Properties of Water-Based Muds | 4-3 | 4-5 |
| Mixing and Handling | 4-4 | 4-8 |
| Drilling and Sampling Problems | 4-5 | 4-8 |
| Limitations and Precautions | 4-6 | 4-13 |
| Good Drilling Practices | 4-7 | 4-14 |
|
 | | |
| Chapter F-5 | | |
| Equipment for Undisturbed Soil Sampling In Borings | | |
| Sampler Types | 5-1 | 5-1 |
| Sample Tubes | 5-2 | 5-11 |

| Subject | Paragraph
(F) | Page
(F-) |
|----------------------------------------------------------|------------------|--------------|
| Chapter F-6 | | |
| Procedures for Undisturbed Soil | | |
| Sampling In Borings | | |
| Advancing the Borehole | 6-1 | 6-1 |
| Stabilizing the Borehole | 6-2 | 6-3 |
| Cleaning the Hole Before Sampling | 6-3 | 6-4 |
| Sampling Procedures | 6-4 | 6-5 |
| Preservation of Samples | 6-5 | 6-11 |
| Boring and Sampling Records | 6-6 | 6-13 |
| Shipment of Samples | 6-7 | 6-14 |
|
 | | |
| Chapter F-7 | | |
| Equipment for Disturbed Soil | | |
| Sampling In Borings | | |
| Sampler Type | 7-1 | 7-1 |
| Augers | 7-2 | 7-1 |
| Push or Drive Samplers | 7-3 | 7-2 |
| Displacement Samplers | 7-4 | 7-3 |
| Vibratory Samplers | 7-5 | 7-4 |
| Percussion Samplers | 7-6 | 7-4 |
|
 | | |
| Chapter F-8 | | |
| Procedures for Disturbed Soil | | |
| Sampling In Borings | | |
| Advancing the Borehole | 8-1 | 8-1 |
| Sampling Procedures | 8-2 | 8-3 |
| Boring and Sampling Records | 8-3 | 8-5 |
| Preservation and Shipment of Samples | 8-4 | 8-5 |
|
 | | |
| Chapter F-9 | | |
| Sampling Frozen Soils | | |
| Introduction | 9-1 | 9-1 |
| Drilling Equipment | 9-2 | 9-2 |
| Drilling and Sampling in Frozen Soil and Ice | 9-3 | 9-7 |
| Special Considerations | 9-4 | 9-9 |
|
 | | |
| Chapter F-10 | | |
| Underwater Sampling of Soils | | |
| Introduction | 10-1 | 10-1 |
| Underwater Sediment Types | 10-2 | 10-1 |
| Planning an Underwater Site Investigation | 10-3 | 10-2 |
| Work Platforms for Underwater Sampling | 10-4 | 10-3 |
| Underwater Samplers | 10-5 | 10-4 |
| Special Considerations for Underwater Sampling | 10-6 | 10-12 |

| Subject | Paragraph
(F) | Page
(F-) |
|---------------------------------------------------------------------------------------|------------------|--------------|
| Sample Handling and Storage | 10-7 | 10-14 |
| Summary | 10-8 | 10-15 |
|
 | | |
| Chapter F-11 | | |
| Sampling from Test Pits, Trenches,
Accessible Borings, or Tunnels | | |
| Introduction | 11-1 | 11-1 |
| Excavation | 11-2 | 11-2 |
| Sampling and Testing | 11-3 | 11-4 |
| Preservation of Samples and Test Records | 11-4 | 11-6 |
| General Safety Considerations | 11-5 | 11-7 |
|
 | | |
| Chapter F-12 | | |
| Sampling from Stockpiles and Bins,
Transportation Units, or Conveyor Belts | | |
| Introduction | 12-1 | 12-1 |
| Sampling Plan | 12-2 | 12-1 |
| Sampling Procedures | 12-3 | 12-3 |
| Required Volume of Samples | 12-4 | 12-5 |
| Preservation of Samples and Test Records | 12-5 | 12-5 |
| Precautions | 12-6 | 12-6 |
|
 | | |
| Chapter F-13 | | |
| Handling and Storage of
Samples and Sampling Records | | |
| Introduction | 13-1 | 13-1 |
| Handling and Storage | 13-2 | 13-1 |
| Written Record | 13-3 | 13-7 |
| Precautions | 13-4 | 13-9 |
|
 | | |
| Chapter F-14 | | |
| Backfilling Boreholes and
Excavations | | |
| General Safety Precautions | 14-1 | 14-1 |
| Grouting | 14-2 | 14-1 |
| Concrete | 14-3 | 14-1 |
|
 | | |
| Appendix F-1 | | |
| References and Bibliography | | |
|
 | | |
| Appendix F-2 | | |
| Artificial Ground Freezing for Undisturbed
Sampling of Cohesionless Soils | | |

EM 1110-2-1804
1 Jan 01

Appendix F-3
Visual Identification of
Soil Samples

Chapter F-1 Introduction

1-1. Purpose

This manual is a discussion of the principles, equipment, procedures, and limitations for obtaining, handling, and preserving soil samples for geotechnical investigations in support of civil and military projects. It is not a comprehensive textbook on soil sampling; the treatment of this subject cannot be substituted for actual experience. Rather, it is a summary of commonly accepted soil sampling practices and procedures which are intended to assist geotechnical personnel performing actual field operations or those personnel functioning as contracting officers' representatives. In most instances, equipment and procedures must be tailored to individual projects and site conditions.

1-2. Applicability

This manual is applicable to HQUSACE elements, major subordinate commands, districts, laboratories, and field operating activities.

1-3. References

The material presented herein has been drawn from many sources. Wherever possible, specific references are cited by the surname of the author(s) or performing agency and date of publication. Appendix A contains a list of required and related publications.

In general, the procedures and practices have been taken from the experience of the U.S. Army Engineer Divisions, Districts, and Laboratories, the U.S. Naval Civil Engineering Laboratory, the U.S. Bureau of Reclamation, standards obtained from the American Society for Testing and Materials (ASTM), and published literature, including textbooks, conference proceedings, periodicals, and professional journals.

1-4. Rescission

This manual supersedes EM 1110-2-1907, dated 31 March 1972.

1-5. Background

Soil sampling operations are routinely conducted in support of geotechnical investigations to determine those conditions that affect the safety, cost effectiveness, and design of a proposed engineering project. The design of the proposed project demands an accurate knowledge of the subsurface conditions and the physical and engineering properties of the foundation materials. The least disturbed "undisturbed" samples are required to determine these properties. Extreme care in the application of sampling methods is demanded to obtain the highest quality undisturbed samples.

Proper sampling of soils and soft or weathered rocks is a combination of science and art. No single sampling device or procedure will produce satisfactory samples in all materials. Different devices and techniques have been developed for drilling and sampling geotechnical materials ranging from soils to rocks. Although many procedures have been standardized, modifications of techniques are often dictated by specific investigation requirements. The highest quality samples are often obtained at the least cost by

using a variety of equipment and techniques applied with experience and sound judgment as dictated by the soil type and subsurface conditions.

1-6. Organization and Scope

This manual establishes guidance for conducting soil sampling operations and handling and storage of samples obtained in support of geotechnical investigations for civil and military projects. It is not meant to be an inflexible description of investigation requirements. Other techniques may be applied as appropriate. Only those soil sampling and handling and storage methods which District or Division staff offices can be reasonably expected to employ have been included. In general, in situ testing methods are not included herein.

Chapter 2 provides guidance for sampling requirements and suggests types of sampling devices which are best suited to obtain samples of various soil types encountered during geotechnical investigations in support of civil and military projects. Chapter 3 discusses drilling equipment that is commonly used during field subsurface investigations. Chapter 4 discusses drilling fluids and additives to enhance drilling and sampling operations. Chapters 5 and 6 present equipment and procedures for obtaining undisturbed soil samples from boreholes. Chapters 7 and 8 present equipment and procedures for obtaining disturbed soil samples from boreholes. Chapters 9 and 10 provide guidance for coring frozen soils and underwater sampling of soils, respectively. Chapter 11 provides guidance for obtaining samples from test pits, trenches, and accessible borings. Chapter 12 suggests procedures for obtaining representative samples from stockpiles and transportation units. Chapter 13 presents guidance for borehole logging and the handling and storage of samples. Chapter 14 offers guidance for backfilling boreholes and excavations. Appendix A lists the references cited in the manual; a bibliography of publications related to sampling operations and procedures is also contained in this appendix. Appendix B presents procedures for conducting the Standard Penetration Test and obtaining disturbed samples with the split-barrel sampling device. Appendix C discusses the use of the Becker hammer drill as an in situ test for assessing the geotechnical engineering properties of gravelly soils. Appendix D suggests a procedure for freezing ground artificially prior to soil sampling operations for geotechnical investigations. Appendix E provides a methodology for visual classification of soil.

This manual does not purport to address all of the safety problems associated with its use or the requirements for sampling, handling, transporting, and storing soils known or suspected to be contaminated with toxic or hazardous materials. It is the responsibility of the user of this manual to establish appropriate safety and health practices and to determine the applicability of regulatory limitations prior to its use.

Chapter F-2 Sampling Requirements

2-1. Introduction

The principal objective of a subsurface investigation is to define the geotechnical engineering characteristics, including permeability, compressibility, and shear strength, of each identifiable soil or rock stratum within a limited areal extent and depth, depending upon the size of the proposed structure. A secondary objective may be to identify and correlate the geology and stratigraphy of like materials. The investigation should be planned within this context to account for appropriate foundation and earthworks design, temporary works design, environmental effects, existing construction, remedial works, and safety checks. These criteria should also be considered for the evaluation of the feasibility and suitability of a particular site.

To fulfill the objectives of the site investigation, the study may be subdivided into five phases: preliminary studies, field subsurface investigation, laboratory testing, reporting, and proposals. The field subsurface investigation is the only phase which falls within the scope of this manual. Preliminary studies, which include the review of published literature, maps, and photographs, and field reconnaissance, are described in EM 1110-1-1804 and other references such as Bell (1987a); Clayton, Simons, and Matthews (1982); Dowding (1979); Mathewson (1981); and Winterkorn and Fang (1975). The laboratory testing phase is discussed in EM 1110-2-1906. A comprehensive list of references cited in this manual are presented in Appendix A. Final reports and proposals are addressed elsewhere.

The comprehensive field subsurface investigation can be executed by using data obtained by remote sensing techniques, such as geophysical methods described in EM 1110-1-1802; by indirect observations which include in situ tests; such as pressuremeter, cone penetration, and plate bearing tests; and by direct observations which include cores, test pits and trenches, and shafts and adits, as well as field reconnaissance. Although the most economical and thorough subsurface investigation can be conducted by integrating all of these technologies, only the direct observation techniques, i.e., drilling and sampling methods, are discussed herein.

Direct observation of subsurface conditions can be obtained by examination of formations through the use of accessible excavations, such as shafts, tunnels, test pits, or trenches, or by drilling and sampling to obtain cores or cuttings. Table 2-1 lists direct methods of subsurface investigations. Test pits and trenches probably offer the best method for observing in situ conditions and obtaining high quality undisturbed samples. A two- or three-dimensional profile of the subsurface strata can be obtained by examination of the walls and floor of the excavation. However, test pits and trenches are generally not economically feasible at depths, especially below the groundwater table.

Core drilling is a fairly economical method for obtaining representative samples at depth. Disturbed samples can be obtained by augering, percussion, and wash boring methods; undisturbed samples can be obtained by employing undisturbed sampling methods which include push tube samples and rotary core barrel samples. The potential for predicting in situ behavior based upon disturbed samples is limited because the effects of sampling disturbance are not totally clear. As compared to the profile obtained from test pits and trenches, only a one-dimensional profile can be obtained from cores and cuttings from boreholes.

Disturbed samples from stockpiles and storage bins can be obtained from hand-excavated trenches or by using power equipment. The sampling methods and procedures are similar to those methods and procedures which are used for obtaining samples from in situ formations. When samples are obtained from stockpiles and storage bins, special care is needed to ensure that the samples are representative, as segregation may occur as a result of the material handling procedures which are employed, i.e., coarser and finer particles tend to segregate as cohesionless soils are end dumped from a conveyor belt.

2-2. Sample Quality

Hvorslev (1949) defined the quality of samples as representative or nonrepresentative. He defined nonrepresentative samples as mixtures of soil and rock from different layers. He further suggested that nonrepresentative samples are normally not useful in site investigations and emphasized that serious errors of interpretation of the soil profile could result due to the mixing of soil cuttings. Nonrepresentative samples are produced by wash boring and bailing and by some types of augering. Hvorslev defined representative samples as those materials which may have been remolded or the moisture content may have changed, although the materials were not chemically altered or contaminated by particles from other layers. Representative samples may be obtained by a variety of techniques, depending upon the quality of sample desired. Disturbed samples can be obtained by augers, sampling spoons, and thick- and thin-walled sampling tubes. Disturbed samples are primarily used for moisture content, Atterberg limits, specific gravity, sieve analysis or grain-size distribution, and compaction characteristics. Strength and deformation tests may be conducted on reconstituted (remolded) specimens of the disturbed materials. Tests on remolded samples are used to predict the behavior of compacted embankments and backfills. Undisturbed samples have been subjected to relatively little disturbance and may be obtained from borings using push-type or rotary-core samplers. High-quality undisturbed samples may be obtained by hand trimming block samples from test pits and trenches. Undisturbed samples are useful for strength, compressibility, and permeability tests of the foundation materials.

2-3. Parameters Which Affect Sample Disturbance

Hvorslev (1949) defined several critical factors which could cause disturbance of the soil during sampling operations. These parameters include area or kerf ratio, friction between the sampling tube and the soil, the length-to-diameter ratio of the sample, sampler driving techniques, stress relief, and failure to recover a sample.

a. Area ratio. Hvorslev stated that the area ratio, C_a , may be the most significant single factor which could influence the quality of the undisturbed sample. He defined the area ratio as

$$C_a = \frac{D_w^2 - D_e^2}{D_e^2} \quad (2-1)$$

where

D_w = external diameter of the cutting shoe

D_e = internal diameter of the cutting shoe

The internal and external diameter of the cutting shoe are illustrated conceptually in Figure 2-1. Permissible area ratios depend upon the soil type, its strength and sensitivity, and the purpose of the sampling operations. Hvorslev suggested that area ratios should be kept to a minimum value, preferably less than 10 to 15 percent. However, small area ratios result in fragile sample tubes which may bend or

buckle during sampling operations. To permit the use of larger area ratio tubes, the International Society for Soil Mechanics and Foundations Engineering (1966) approved the use of larger area ratios provided that cutting edge taper angles were changed. The Committee suggested that as area ratios were increased from 5 to 20 percent, the edge taper angles should be decreased from 15 to 9 degrees (deg).

b. Inside clearance ratio. Friction between the soil sample and inside wall of the sample tube may be reduced by cutting the diameter of the sample slightly smaller than the inside diameter of the sample tube. The inside clearance ratio, or swage, C_i , is defined as

$$C_i = \frac{D_s - D_e}{D_e} \quad (2-2)$$

where D_s is the inside diameter of sampling tube. The inside diameter of sampling tube and the internal diameter of the cutting shoe are illustrated conceptually in Figure 2-1. Hvorslev suggested that ratios of 0 to 1 percent may be used for very short samples, values of 0.5 to 3 percent could be used for medium length samples, and larger ratios may be needed for longer samples. For most soils, an inside clearance ratio of 0.75 to 1.5 percent is suggested for samples with a length-to-diameter ratio of 6 to 8, i.e., medium length samples. However, the clearance ratio should be adjusted as required by the character of the soil.

c. Outside clearance ratio. The outside wall friction may also influence the quality of the soil sample. Severe wall friction may be transmitted to the soil lying beneath the bottom of the sampler, and a bearing capacity failure could result. If a bearing capacity failure occurred during the sampling operations, the material entering the tube could be rendered useless even for visual examination. The practical range for outside clearance ratios should be less than 2 to 3 percent for cohesive soils and zero for cohesionless soils, although these values may require adjustment for the character of the soil. The outside clearance ratio, C_o , is defined as

$$C_o = \frac{D_w - D_t}{D_t} \quad (2-3)$$

where D_t is the outside diameter of sampling tube. The outside diameter of sampling tube and the external diameter of the cutting shoe are illustrated conceptually in Figure 2-1.

d. Length-to-diameter ratio. The maximum length for an undisturbed sample which can be obtained in a single sampling operation is dependent upon the type of soil, the sampler, the rate and uniformity of penetration, the inside clearance ratio, and the depth below the ground surface. Suggested ratios of length to diameter of the sample should be limited to 5 to 10 for cohesionless soils and 10 to 20 for cohesive soils, although these ratios may vary as a result of the variables encountered and the type of sampler employed. The diameter of the sample should be selected based upon the type of soil, the laboratory requirements, and practical considerations, such as availability of equipment.

e. Advancing the sample tube. The method of advancing the sample tube affects the disturbance of the soil. Driving the sample tube by hammering causes the greatest amount of disturbance. Pushing the sampling tube with a fast, continuous, uniform motion is recommended as a suitable method of advancing the sample tube in most soils.

f. Stress relief. Stress relief can result in base heave, caving, and piping in the borehole. The borehole may be stabilized by using water, drilling mud, or casing. Water is the least effective method. It works by reducing the effective stresses along the sides and bottom of the borehole and decreasing the groundwater flow into the borehole. Although this method may not be successful for many soils, it may

work well in soft cohesive alluvial deposits. Drilling mud, which usually consists of bentonite mixed with water in a ratio by weight of approximately 1:15 to 1:20, has several advantages over water. The unit weight of drilling mud is slightly higher than the unit weight of water and thus reduces the effective stresses within the subsurface formations. The drilling mud forms a filter or wall cake which reduces seepage as well as the rate and amount of swelling for water sensitive deposits. Disadvantages include increased costs and the need for disposal of the drilling mud after the drilling operations have been completed. Steel casing can also be used to prevent wall collapse but may disturb the soil formation during its placement. The use of casing may be limited by economic considerations.

g. Sample recovery. Poor sample recovery may be the most serious result of sample disturbance and may be dependent on a number of factors which include:

(1) Increased pressure at the top of the sample due to improper venting of the sample tube during sampling operations. The pressure tends to force the soil from the tube as the sample is extracted from the boring.

(2) Suction below the sample tube results as the tube is pulled from the soil deposit. Several techniques, including the use of a piston sampler which opposes with a vacuum or suction as the sample tends to slide from the tube, enhance the length and degree of sample recovery.

(3) The tensile strength of the soil must be overcome to separate the soil sample from the soil deposit. This separation may be accomplished by rotating the sampling tube one or two revolutions to shear the sample at the base of the cutting shoe. Other techniques are: (a) allowing a short rest period after sampling to permit the soil to swell and increase adhesion with the wall of the sample tube, (b) slight overdriving which increases sample disturbance but simultaneously increases adhesion between the sample and sample tube wall, and (c) the use of core catchers. It should be noted that core catchers tend to increase the disturbance around the edge of the sample. The area ratio of the cutting shoe may also have to be increased to accommodate the core catcher.

(4) Remolding of soils adjacent to the sampler walls may reduce the chances of recovery, especially for sensitive soils. A small area ratio and cutting edge with increased swage taper may be essential to obtain quality samples of many soils.

Hvorslev (1949) attempted to conduct a qualitative assessment of sampling disturbance by the use of a ratio of the length of the recovered sample to the length of the sample drive or push. He called this quantity "recovery ratio." Although the recovery ratio is probably an index of sample quality, many variables affected the ratio. Unfortunately, Hvorslev was unable to isolate the criteria required to assess sample disturbance using the recovery ratio concept.

Disturbance which occurs after sampling may result from a change of water content, moisture migration within the sample, the penetration of voids by wax used to seal the sample, vibrations during the transport of samples, freezing of silt or clay samples, chemical reaction between the soil sample and the tube, or disturbance caused by extruding the sample from the tube.

It is important that practices are adopted to obtain the highest quality sample at the least cost. Undisturbed sampling should be conducted in a manner to minimize: (a) changes of void ratio and water content, (b) mechanical disturbance of the soil structure, and (c) changes of stress conditions. Efforts should also be undertaken to eliminate other causes of disturbance, such as chemical changes, caused by prolonged storage in metal containers. A summary of the principal causes of soil disturbance is presented in Table 2-2.

2-4. Selection of Sampling Apparatus to Obtain Undisturbed Samples

Although the least disturbed samples are probably obtained by the hand trimming method in test pits and trenches using the advanced trimming technique, the depth at which samples can be obtained economically usually limits the use of test pits for sampling operations. Consequently, other sampling techniques must be employed. Two basic types of sampling apparatus which have been developed are (i) push-tube samplers and (ii) core barrel samplers. Additional details describing equipment and procedures for undisturbed sampling operations are discussed in Chapters 5 and 6, respectively.

a. Push-tube samplers. Push-tube samplers are pushed into the soil without rotation. The volume of soil which is displaced by the sampling tube is compacted or compressed into the surrounding soils. Thin-walled push-tube samplers can be subdivided into two broad groups: open-tube samplers and piston samplers. Open-tube samplers consist of open tubes which admit soil as soon as they are brought in contact with it. Many open samplers have a ball check valve located in the sampler head which connects the sample tube to the drill string. The purpose of the check valve is to help retain the sample in the sampling tube during extraction. Piston samplers have a piston located within the sampler tube. The piston helps to keep drilling fluid and soil cuttings out of the sampling tube as the sampler is lowered into the borehole. It also helps to retain the sample in the sampling tube.

(1) *Open-tube samplers.* Open-tube samplers for undisturbed sampling are thin-walled tubes. The thin-walled open-tube push sampler consists of a Shelby tube affixed to the sampler head with Allen head screws as suggested by ASTM D 1587-74 (ASTM 1993). Most tubes are drawn to provide a suitable inside clearance. The cutting edge of the sampling tubes is normally sharpened. Thin-walled sample tubes may be easily damaged by buckling, blunting, or tearing of the cutting edge as they are advanced into stiff or stony soils. Open-tube samplers have advantages due to cheapness, ruggedness, and simplicity of operation. The disadvantages include the potential for obtaining nonrepresentative samples because of improper cleaning of the borehole or collapse of the sides of the borehole. An increase of pressure above the sample during sampling operations and a decrease of pressure caused by sample retention during the withdrawal of the sampling tube from the borehole may also influence the quality of the sample. Hence, open-tube samplers are generally not recommended for undisturbed sampling operations.

(2) *Piston samplers.* Pistons have been incorporated into sampler designs to prevent soil from entering the sampling tube before the sampling depth is attained and to reduce sample loss during withdrawal of the sampling tube and sample. The vacuum which is formed by the movement of the piston away from the end of the sampling tube during sampling operations tends to increase the length to diameter ratio. The advantages of the piston samplers include: debris is prevented from entering the sampling tube prior to sampling; excess soil is prevented from entering the sampling tube during sampling; and sample quality and recovery is increased. Hvorslev (1949) stated that the fixed-piston sampler "has more advantages and comes closer to fulfilling the requirements for an all-purpose sampler than any other type." The principal disadvantages of piston samplers include increased complexity and cost.

Three general types of piston samplers are free-piston samplers, fixed-piston samplers, and retractable-piston samplers.

(a) Free-piston samplers have an internal piston which may be clamped during insertion or withdrawal of the sampling tube. During actual sampling operations, the piston is free to move with respect to the ground level and sample tube. Free-piston samplers have overcome many of the shortcomings of open-tube samplers while remaining easy to use. Principal advantages include: the sample tube can be pushed through debris to the desired sampling depth and the piston creates a vacuum on the top of the sample which assists in obtaining increased sample recovery.

(b) To obtain a sample with a fixed-piston sampler, the sampling apparatus is lowered to the desired level of sampling with the piston fixed at the bottom of the sampling tube. The piston is then freed from the sampler head, although it remains fixed relative to the ground surface, i.e., it can be affixed to the drill rig. The sample is obtained, and the piston is again clamped relative to the sampler head prior to the removal of the sample and sampling tube from the borehole. The Osterberg sampler and the Hvorslev sampler are fixed-piston samplers commonly used by the Corps of Engineers.

(c) The retractable-piston sampler uses the piston to prevent unwanted debris from entering the sample tube while the sampler is lowered to the desired sampling depth. Prior to the sampling operation, the piston is retracted to the top of the tube. However, this operation may cause soil to flow upward into the tube; if this occurs, the quality of the sample is suspect. The retractable piston sampler is not recommended for undisturbed sampling operations.

(d) A modified form of the fixed-piston sampler is the foil or stockinette sampler. The principle of operation is similar to the fixed-piston sampler. As the sample is obtained, the piston retracts from the sampler head, and a sliding liner, which is attached to the piston, unrolls from its housing located within the sampler head. The foil or stockinette sampler was designed to obtain samples with an increased length-to-diameter ratio by reducing friction between the sample and the wall of the sampling tube. Long samples can provide a more comprehensive understanding of a complex soil mass, such as varved clay. This type of sampler has also been used to obtain samples of soft clay and peat. The principal disadvantages of the foil or stockinette sampler include large operating expenses and increased potential of sample disturbance due to the larger area ratio of the cutting shoe. Examples of the sampler included the Swedish foil sampler and the Delft stocking sampler.

b. Core barrel samplers. Rotary core-barrel samplers were originally designed for sampling rock, although a variety of rotary samplers have been developed to sample materials from hard soils to soft rock. The principle of operation consists of rotating a cutting bit and applying a downward force from the ground surface with a drill rig. As the cutting edge is advanced, the sample tube is pushed over the sample. Drilling fluid, such as air or drilling mud, is used to cool the drill bit and remove the cuttings from the face of the bit.

Rotary core-barrel samplers have evolved from a single-tube sampler to double- and triple-tube samplers. The rotation of the core barrel of the single-tube sampler during the coring process presented a high potential for shearing the sample along planes of weakness. The design of the single-tube core barrel also exposed the core to erosion or degradation by the drilling fluid which was passed along its entire length. The double- and triple-tube core barrels were designed to minimize these problems. The double-tube core barrel sampler consists of an inner stationary tube and an outer tube which attaches the cutting bit to the drill rods. Drilling fluid is pumped through the drill rods and between the inner and outer barrels before being discharged through ports inside the cutting face of the bit. A modification of this technique is to discharge the drilling fluid through ports located on the face of the bit, i.e., bottom discharge bit. A spring catcher is frequently used to prevent loss of the core during the extraction process. The triple-tube core barrel consists of a double-tube core barrel which has been modified to accept a sample liner. The liner reduces the potential damage to the core as the sample is extracted from the inner tube. The liner also serves as a container to ship the core.

Core barrel samplers have a larger area ratio and inside clearance ratio than are generally accepted for push-tube samplers. The larger area ratio may be considered advantageous as it decreases the stress at the cutting bit during the drilling operations. However, the larger inside clearance ratio may not provide adequate support to the sample. During the drilling operations, the sample may be damaged by vibrations of the rotating core barrel. Another disadvantage is that although the inner core barrel may protect the

core from erosion by the drilling fluid, water sensitive formations may be continuously in contact with the drilling fluid.

Two principal types of double- or triple-tube core barrel samplers include the Denison sampler and the Pitcher sampler.

(1) The Denison core barrel sampler consists of an inner liner, an inner barrel with an attached cutting edge, and an outer rotating barrel with attached cutting teeth. The protrusion of the inner barrel must be adjusted in advance of the drilling operations for the anticipated stiffness of the soil to be sampled. It can precede the cutting teeth for soft soils or can be flush with the cutting teeth for stiffer soils. The principal disadvantage of this type of sampler is that the protrusion of the inner tube must be selected in advance of the drilling operations. To overcome this problem, core barrel samplers with a spring-mounted inner barrel such as the Pitcher sampler, were developed.

(2) The Pitcher sampler consists of an inner barrel which is a thin-walled sample tube with a cutting edge. The tube is affixed to an inner sampler head. The outer rotating barrel has a cutting bit attached. After the sampler has been lowered into the borehole but before it has been seated on the soil, debris can be flushed from the sample tube by drilling fluid which is passed down the drill rods through the inner barrel. Once the inner tube is seated, drilling fluid is passed between the inner and outer tubes. A spring-loaded inner head assembly governs the lead of the inner tube cutting edge with respect to the cutting bit. For softer formations, the cutting edge of the sample tube precedes the cutting bit. For stiffer soils, the cutting edge of the tube may be flush with the cutting bit. Although it has been observed in practice that alternating soil and rock layers may frequently damage the rather light sampling tube, this sampler may be used in formations of variable hardness where the push-tube sampler cannot penetrate the formation and the rotary core-barrel sampler does not protect the sample from erosion by the drilling fluid.

c. Sand samplers. Obtaining high-quality undisturbed samples of sand has been rather elusive. Hvorslev (1949) suggested several methods including the use of thin-walled fixed-piston samplers in mudded holes, open-tube samplers using compressed air, in situ freezing, and impregnation.

(1) The U.S. Army Engineer Waterways Experiment Station (1952) and Marcuson and Franklin (1979) reported studies using the thin-walled fixed-piston sampler. Pre- and post-sampling densities were compared. Generally, loose samples were denser and dense samples were looser.

(2) Bishop (1948) developed a sampler for sand. A differential pressure was employed to enhance the capability of retaining the sample in the sampling tube.

(3) Torrey, Dunbar, and Peterson (1988) reported an investigation of point bar deposits along the Mississippi River. The Osterberg fixed-piston sampler was used to obtain samples of fine sand below the water table. Although data were not available regarding the degree of disturbance, it was judged that high-quality samples were obtained based upon the comparison of all test results, including in situ tests, nuclear density tests, the examination of x-ray records for all undisturbed samples, laboratory tests, and data from previous potamology studies.

(4) Seed et al. (1982) reported an investigation of the effects of sampling disturbance on the cyclic strength characteristics of sands. They determined that the Hvorslev fixed-piston sampler caused density changes, whereas the advanced trimming and block sampling techniques caused little change in density, although some disturbance due to stress relief was reported.

(5) Singh, Seed, and Chan (1982) reported a laboratory study of techniques for obtaining undisturbed samples of sands. Unidirectional freezing with no impedance of drainage was followed by rotary core barrel sampling. Experimental data demonstrated that the freezing method could be used to obtain laboratory samples which maintained the in situ characteristics, including applied stress conditions.

(6) Schneider, Chameau, and Leonards (1989) reported a study to assess impregnation as a method for stabilizing cohesionless soils prior to conducting undisturbed sampling operations. They suggested that the impregnating material should readily penetrate the soil and must be easily and effectively removed at a later date. They also reported that impregnation of soil was fairly expensive and rather difficult to execute. Because of these considerations and limitations, Schneider, Chameau, and Leonards stated that chemical impregnation of soil has been generally limited to the laboratory environment, although they concluded that the technology could be readily applied to the field environment.

Although the technology is somewhat limited, data are available which indicate that high-quality undisturbed samples of sand can be obtained. However, the sampling techniques must be tailored to the characteristics of the formation and the requirements of the investigation. Furthermore, the allowable degree of disturbance to the “undisturbed” samples must be considered.

The highest quality undisturbed samples of medium to fine sands can be obtained by hand trimming or in situ freezing and core drilling. For shallow depths above the groundwater table, high quality samples can be obtained by hand trimming methods using the cylinder with advanced trimming technique. Below the groundwater table, in situ freezing with core drilling is a method which can be used to obtain high-quality samples. Another method which yields good quality samples of sand below the water table is the use of the fixed-piston sampler in a mudded borehole. For dry formations, impregnation of the material to be sampled may be the most suitable method for obtaining undisturbed samples. For coarser sands and gravelly soils, methods which are similar to the methods for sampling medium to fine sands can be used. It is suggested that the minimum diameter of the sample must be at least six times larger than the size of the largest particle.

The geotechnical engineer or engineering geologist should be aware that hand trimming samples, in situ freezing and coring, or impregnation of the material to be sampled is expensive. The additional costs must be considered before the investigation is begun. If the hand trimming method is selected, cribbing and shoring of the walls of the excavation may be needed. If in situ freezing is selected, the formation must be free draining and the field freezing procedures must be designed to ensure that the freezing front advances one dimensionally. The costs and logistics of the additional field support equipment should also be considered. If impregnation is used, coordination with the laboratory is mandatory to ensure that the impregnation material can be removed prior to laboratory testing.

d. Selection of sampling device. The data which are presented in Table 2-3 may be used as a preliminary guide for selecting a sampling apparatus and/or method for obtaining undisturbed samples of various materials. However, other factors, such as soil conditions, equipment availability, costs, and operator experience, may dictate the selection of an alternative sampling apparatus.

2-5. Borehole Layout, Depth and Interval of Sampling, and Sample Diameter

The borehole layout, sampling interval, and depth of samples are controlled to a major extent by the complexity of the geological conditions, the availability of equipment, and the type of project and its size. There are no hard and fast rules stating the number and depth of samples for a particular geotechnical investigation. Although considerable knowledge of the geological conditions may be available from the preliminary studies, including the review of the literature, maps, photographs, and the site reconnaissance, the site investigation is frequently a “learn as you go” operation. A guide for planning the boring program is suggested in the following paragraphs. The user is reminded, however, that each boring and sampling program must be planned and executed within monetary constraints with appropriate consideration given to other variables which may affect the site investigation.

Most geotechnical investigations fall into one of the following categories, or combination of categories, depending upon the size of the project:

- a.* Small isolated structures, such as houses. One borehole may be sufficient, especially if a number of small structures are placed relatively close together and the geology does not vary significantly over the site.
- b.* Compact projects, such as buildings and landslides. The borings may be relatively deep and closely spaced.
- c.* Extended projects such as highways, airport runways, electrical powerlines and pipelines, and reservoirs. Except for reservoirs, the borings may be relatively shallow and widely spaced. The spacing or frequency of the borings must be judged depending upon the site variability. For reservoirs, the depths of borings may be considerable to define the limits of impermeable soil.

Hvorslev (1949) suggested the following general considerations for planning the subsurface investigation:

“The borings should be extended to strata of adequate bearing capacity and should penetrate all deposits which are unsuitable for foundation purposes - such as unconsolidated fill, peat, organic silt and very soft and compressible clay. The soft strata should be penetrated even when they are covered with a surface layer of high bearing capacity. When structures are to be founded on clay and other materials with adequate strength to support the structure but subject to consolidation by an increase in the load, the borings should penetrate the compressible strata or be extended to such a depth that the stress increase for still deeper strata is reduced to values so small that the corresponding consolidation of these strata will not materially influence the settlement of the proposed structure.

Except in the case of very heavy loads or when seepage or other considerations are governing, the borings may be stopped when rock is encountered or after a short penetration into strata of exceptional bearing capacity and stiffness, provided it is known from explorations in the vicinity or the general stratigraphy of the area that these strata have adequate thickness or are underlain by still stronger formations. When these conditions are not fulfilled, some of the borings must be extended until it has been established that the strong strata have adequate thickness irrespective of the character of the underlying material.

When the structure is to be founded on rock, it must be verified that bedrock and not boulders have been encountered, and it is advisable to extend one or more borings from 10 to 20 ft into solid rock in order to determine the extent and character of the weathered zone of the rock.

In regions where rock or strata of exceptional bearing capacity are found at relatively shallow depths - say from 100 to 150 ft - it is advisable to extend at least one of the borings to such strata, even when other considerations may indicate that a smaller depth would be sufficient. The additional information thereby obtained is valuable insurance against unexpected developments and against overlooking foundation methods and types which may be more economical than those first considered.

The depth requirements should be reconsidered, when results of the first borings are available, and it is often possible to reduce the depth of subsequent borings or to confine detailed and special explorations to particular strata.”

The primary exploratory borings should provide nearly continuous samples for classification and logging. However, sampling plans should be flexible to permit samples to be obtained for specific testing requirements or to answer questions regarding stratification changes, anomalies, etc. Although the boring plan and sampling interval is the responsibility of the geotechnical personnel, field conditions may demand that the inspector and the drill rig operator use judgment and modify the investigation to obtain complete and comprehensive information on the site conditions. Changes to the program, i.e., depth of borings, number of borings, and spacing of boreholes, may be required, depending upon the subsurface conditions which are encountered.

Table 2-4 is presented as a preliminary guide for geotechnical personnel for planning the boring and sampling program. This program is not intended to be a rigid requirement for Corps' geotechnical site investigations. It is suggested merely as guide for preliminary planning of the boring and sampling program. Although the data in this table suggests only undisturbed sampling operations, common sense directs that some general sample (disturbed) borings are needed to guide the planning for the more expensive undisturbed sampling locations, depths, and sampling intervals. The final boring program should be sufficiently flexible to permit geotechnical personnel to obtain a comprehensive understanding of the site, including anomalies or other features, while operating within budget and time constraints.

Table 2-5 provides the project engineer with guidance for selecting the appropriate diameter of sample or core which is compatible with the desired laboratory tests on undisturbed specimens or the required weight of material for tests on reconstituted soil specimens. A small specimen should be taken from the bottom of each undisturbed sample. This material may be used for classification and water content determinations. Although the small specimen may not represent the entire sample, a descriptive log of the boring and these specimens provide a basis for assigning laboratory tests.

Table 2-1
Direct Observation of Subsurface Conditions (after U.S. Department of the Interior, Bureau of Reclamation 1974)

| Method | Type of Excavation or Boring | Remarks |
|--------------------------------|-----------------------------------------|------------------------------------------------------------------------------------------------------------------------------------------------------------------------------------------------------------------------------------------------------------------------------|
| In Situ Examination | Test pits/trenches | Excavation can be dug by hand or machine. The depth is usually limited to the depth of the water table. Shoring and cribbing are required for depths greater than approximately 1.2 m (3.9 ft). |
| | Large bored shafts, tunnels, and drifts | The excavation is fairly expensive. There may be a smear zone due to augering. Limitations may include confined working space and difficulty of identifying discontinuities. |
| | Borehole cameras | Dry hole is necessary to permit the examination of joints. |
| Boring and Drilling Techniques | Hand augering | Light, portable method of sampling soft to stiff soils near the ground surface. |
| | Light percussion (Shell and auger) | In clays, steel tube is dropped; soil is wedged inside. In granular soils, water is placed in bottom of cased borehole. Shell is surged to loosen the soil which precipitates in a tube on top of the shell. |
| | Power auger drilling | Bucket or auger is connected to drill rods. Torque is transmitted to auger by the kelly. Flight augers (continuous- or short-flight) may be hollow- or solid-stem. Soils may be mixed and nonrepresentative. Heavy downward pressure disturbs soils in advance of the auger. |
| | Wash boring | Soil particles are eroded and moved to the surface by jetting water from a bit at the base of the drill string. The drill rod is continuously rotated and surged as the borehole is advanced. Soils may be mixed and nonrepresentative. |
| | Rotary core drilling | Combined action of downward force and rotary action. Most common equipment is a core barrel fitted with a cutting bit. Modifications to rotary core drilling method include open-drive samplers and piston samplers. |

Table 2-2
Causes of Soil Disturbance

| Before Sampling | During Sampling | After Sampling |
|-----------------|---------------------------|-------------------------------------------------------|
| Base heave | Failure to recover | Chemical changes |
| Piping | Mixing or segregation | Migration of moisture |
| Caving | Remolding | Changes of water content |
| Swelling | Stress relief | Stress relief |
| Stress relief | Displacement | Freezing |
| Displacement | Stones along cutting edge | Overheating |
| | | Vibration |
| | | Disturbance caused during extrusion |
| | | Disturbance caused during transportation and handling |
| | | Disturbance caused due to storage |
| | | Disturbance caused during sample preparation |

Table 2-3
Guide for Selecting Sampler for Obtaining High Quality Undisturbed Samples

| Soil Type | Suggested Sampler Type or Method |
|-----------------------------------------------------------------------------|-----------------------------------------------------------------------------------------------------------------------------|
| Very soft cohesive soils
Organic soils
Varved clays | Stockinette sampler, foil sampler, or fixed-piston sampler |
| Soft-to-medium cohesive soils | Fixed-piston sampler |
| Fine-to-medium sands above the water table | Hand trimming using the cylinder with advanced trimming technique
Fixed-piston sampler in a cased and/or mudded borehole |
| Fine-to-medium sands below the water table | In situ freezing and coring
Fixed-piston sampler in a mudded borehole |
| Alternating layers of soil and rock
Hard or dense cohesive soils
Rock | Rotary core-barrel sampler |

**Table 2-4
Suggested Boring Program for Various Engineering Structures (after Dunlap 1980) (Continued)**

| Structure | Number of Borings/Spacing | Depth of Borings | Remarks |
|---------------------------------------|-----------------------------------------------------------------------------------------------------------------------------------------------------------------------------------------------------------------------|--------------------------------------------------------------------------------------------------------------------------------------------------------------------------------------------------------------------|--------------------------------------------------------------------------------------------------------------------------------------------------------------------------------------------------------------------------------------------------------------------------------------------------------------------------------------------------------------------------------------------------------------------------------------------------------------------------------------------------------------------------------------------------------------------------------------------------------------------------------------------------------------------------------------------------------------------------------------------------------------|
| Rigid frame structure | 1 boring per 230 sq m ¹ of ground floor area | 1-1/2 times the minimum dimension of footing below the base of the footing
Pile footings - 1-1/2 times the minimum dimension of an imaginary footing located at 2/3 of the expected depth of piles
CPT tests | Cohesive soils - continuous undisturbed samples for the first 3 meters.
- intermittent samples at 1-1/2 to 3 m intervals thereafter
- sample at every change of soil type
Cohesionless soils - obtain undisturbed samples (if possible) or conduct in situ soundings such as SPT or |
| Continuous truss (girder)-type bridge | Minimum of 1 boring at every pier/footing

- pier size > 250 sq m - minimum of 5 continuous undisturbed samples at each pier | 1-1/2 times the minimum dimension of footing below the base of the footing
Pile footings - 1-1/2 times the minimum dimension of an imaginary footing located at 2/3 of the expected depth of piles | Cohesive soils - pier size < 50 sq m - continuous undisturbed samples at each pier
- pier size - 50 to 100 sq m - 2 continuous undisturbed samples at each pier
- pier size - 100 to 250 sq m - 4 continuous undisturbed samples at each pier

Cohesionless soils - obtain undisturbed samples or soundings as for cohesive soils
Competent rock - trace formation at each pier - if in doubt of rock quality, drill at least 6 m into formation |
| Levees | Levee height = 3 to 6 m; space borings at 300 m intervals

Levee height = 6 to 12 m; space borings at 230 m intervals
Levee height = 12 to 18 m; space borings at 150 m intervals | Depth of boring - 6 m

Depth at least equal to height of levee
Depth at least equal to height of levee | Cohesive soils - continuous undisturbed samples
Cohesionless soils - continuous undisturbed samples or soundings
Locate borings along centerline of proposed structure |
| Earth dams | See remarks column | Depth at least equal to height of dam or twice the maximum head, whichever is greater
Trace the top of the impervious zone | Preliminary investigation - maximum stress occurs approximately at midpoint of slope between the centerline and toe of proposed structure. Establish a square grid pattern of borings located upstream and downstream of dam centerline near midpoint of slope in a direction with respect to dam centerline

Primary investigation - trace the limits of various strata, e.g., sand
- treat power plants, spillways, and other control structures as rigid frame structures
- obtain adequate subsurface data to define the character of the abutments

Obtain in situ permeability and pore pressure measurements
Cohesive soils - continuous undisturbed samples
Cohesionless soils - continuous undisturbed samples or soundings |
| Borrow pits | Use a 60-m grid spacing | Maximum depth to water table or working depth of equipment | Disturbed samples are satisfactory; may use augers to obtain samples |
| Roads | For 2 lane highways:
1 boring per 150 m along centerline and at each major change of soil profile
For multilane highways:
1 boring per 75 m along centerline; borings may be staggered
See remarks column | For excavations and level terrain:
3 m below level finished grade
For compacted embankments: treat as for levees
For rock: extend 0.75 m into rock | Cohesive soils - continuous undisturbed samples
Cohesionless soils - continuous undisturbed samples or soundings |
| Airfields | See remarks column | See remarks column | Preliminary investigation - place borings at 300 m intervals in square grid patterns to a depth of 6 m. Samples may be disturbed. Site facilities based upon preliminary investigation.
Primary investigation - Runways - site two lines of borings in a square grid pattern at 30 m on either side of runway centerline to a depth of 6 m or 1.5 m into rock
- Taxiway - place borings at 60 to 76 m intervals along centerline to a depth of 6 m
- Apron - place borings in a 60 to 75 m square grid pattern to a depth of 6 m |
| Houses | 1 boring per 8000 sq m in new subdivision
1 boring per individual lot | To unweathered rock or to 4.5 m, whichever is lesser | Obtain samples at 1.5 m intervals using undisturbed sampling techniques for cohesive soils or undisturbed or sounding techniques for cohesionless soils |

¹ 1 m = 3.28 ft; 1 m² = 10.76 ft²

Table 2-5
Minimum Sample Diameter or Dry Weight for Selected Laboratory Tests

| Sample Type | Test | Minimum Sample Diameter ¹ | | Minimum Dry Weight ¹ | |
|---------------|---------------------------------------------|--------------------------------------|------------------|---------------------------------|------|
| | | cm | in. | kg | lb |
| Undisturbed | Unit weight | 7.6 | 3.0 | ---- | ---- |
| | Permeability | 7.6 | 3.0 | ---- | ---- |
| | Consolidation | 12.7 | 5.0 | ---- | ---- |
| | Triaxial compression | 12.7 | 5.0 ² | ---- | ---- |
| | Unconfined compression | 7.6 | 3.0 | ---- | ---- |
| | Direct shear | 12.7 | 5.0 | ---- | ---- |
| Disturbed | Water content | ---- | --- | 0.2 | 0.5 |
| | Atterberg limits | ---- | --- | 0.2 | 0.5 |
| | Shrinkage limits | ---- | --- | 0.2 | 0.5 |
| | Specific gravity | ---- | --- | 0.1 | 0.2 |
| | Grain-size analysis | ---- | --- | 0.2 | 0.5 |
| Reconstituted | Standard compaction | ---- | --- | 13.5 | 30.0 |
| | Permeability | ---- | --- | 0.9 | 2.0 |
| | 10.2-cm-diam consolidation | ---- | --- | 0.9 | 2.0 |
| | Direct shear | ---- | --- | 0.9 | 2.0 |
| | 3.6-cm-diam triaxial (4 points) | ---- | --- | 0.9 | 2.0 |
| | 7.2-cm-diam triaxial (4 points) | ---- | --- | 4.5 | 10.0 |
| | 15-, 30-, or 38-cm-diam triaxial (4 points) | ---- | --- | Coordinate with laboratory | |
| | Vibrated density | ---- | --- | Coordinate with laboratory | |

¹ All particles pass the U.S. Standard Sieve No 4 (3.8 mm)

² Triaxial test specimens are prepared by cutting a short section of a 12.7- cm- (5-in.-) diam sample axially into four quadrants and trimming each quadrant to the proper size. The material from three quadrants can be used for three tests representing the same depth. The material from the fourth quadrant is usually preserved for a check test.

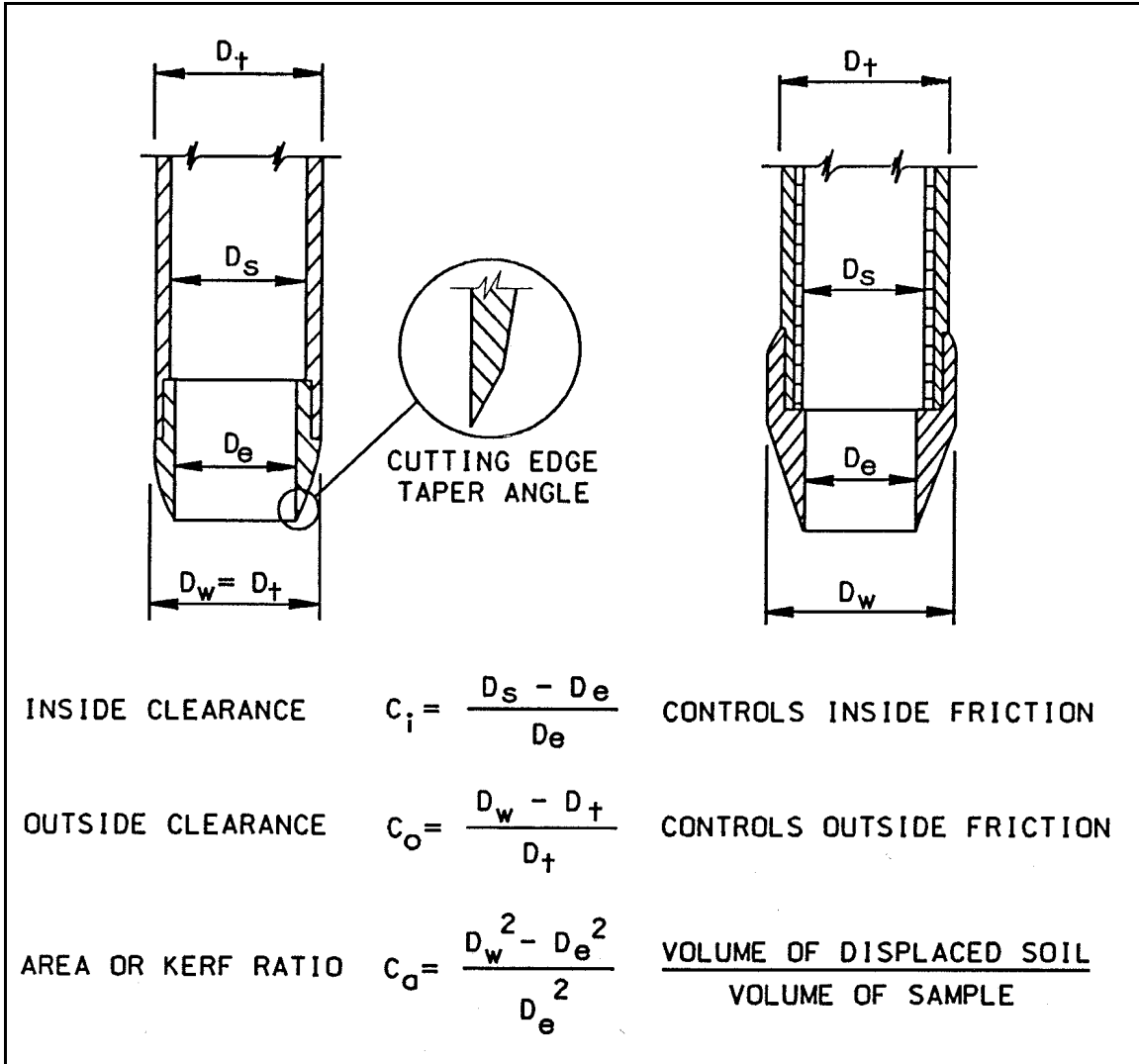

Figure 2-1. Parameters which affect sample disturbance: a schematic of a sampling tube and cutting shoe (after Hvorslev 1949)

Chapter F-3 Drill Rigs and Appurtenant Equipment

3-1. Introduction

A number of commercially available drill rigs and accessories are satisfactory for performing conventional drilling and sampling operations or for conducting in situ tests. Although some types of drill rigs are more readily adapted to specific work, the selection of the drill rig and appurtenant equipment is usually based upon the requirements of the geotechnical investigation. Factors which may affect the selection include site accessibility, the type or hardness of material to be sampled and the degree of disturbance which is acceptable, equipment availability, time and mobilization costs, the number of personnel required, plant rental costs, etc. A discussion of various types of drill rigs and accessories and appurtenant equipment, including those apparatus to advance and stabilize the borehole, is presented in this chapter. The discussion of sampling devices is presented in Chapters 5 through 8.

3-2. Drill Rigs

Drill rigs vary from small electric motors to large oil field rigs. The basic elements of an aboveground drill rig are the power source or motor, a pump or air compressor for circulating drilling fluid to the bit and cleaning the borehole, a drill head, hoisting drums and cables, a derrick, a mounting platform or deck, and assorted equipment which includes one or more hammers for driving and removing casing, a portable mud pit, racks for stacking the drill rods and samples, and small tools for coupling or uncoupling and hoisting the drill string, etc. A discussion of the basic components of commonly used drill rigs is presented in the following paragraphs.

a. Power source. A power source or motor is required to operate a drive weight mechanism for percussion or churn drilling or to provide rotary motion to turn augers and coring equipment for rotary drilling operations. Other requirements include operating a winch for raising and lowering the drilling and sampling equipment, providing downward pressure for pushing boring and sampling equipment, or lifting and dropping a hammer to drive casing or sampling equipment. For most drilling and sampling operations, the power source is the power takeoff from the truck motor on which the drilling machine is mounted or from a separate engine which is assigned or attached as an integral component of the drilling rig. It is estimated that 90 percent of the motors are gasoline or diesel engines and 10 percent are compressed air or electric motors. A drive train which consists of gears or hydraulic pumps is used to convert the power supply to speed and torque for hoisting and rotating the drilling equipment. Most units have a transmission which allows 4 to 8 speeds for hoisting and drilling. In general, the hoisting capacity of the drill rig governs the depth of the borehole. A rule of thumb for selecting the power source is the horsepower which is required to hoist the drill rods should be about three times the horsepower which is required to turn the drill string. For high elevations, the power loss is about 3 percent for each 300 meters (m) or 1,000 feet (ft) above sea level.

b. Fluid pump and accessories. Drilling fluid, such as compressed air or drilling mud, is required for removing the cuttings from the drill bit and the borehole and cooling the bit. Compressed air has been used to a limited extent, especially for water sensitive formations. Clear-water and bentonite-based drilling muds are the work horses for geotechnical investigations. Drilling fluids are discussed in Chapter 4.

To circulate drilling mud, a pump and hoses, a water swivel, and a settling system are required. The two most common types of pumps that are available are the progressive cavity type and the triplex piston type. Both types of pumps can be used for drilling mud or clear water. Pressures ranging from 0 to 4.5 megapascals (MPa) or 0 to 650 pounds per square inch (psi) at flowrates of 0 to 130 cubic decimeters per minute (dm^3/min) or 0 to 35 gallons per minute (gpm) are needed for most geotechnical drilling operations. The progressive cavity (or Moyno) pump is used for most geotechnical operations. It can pump drilling mud in great capacities at low pressures. The efficiency of the pump is about 80 percent. For deep borings or when a high-efficiency pump is needed, the piston pump can be used. The pumping system is usually mounted as a part of the drill rig using the same power source although a separate pump system can be used, depending on the requirements of the investigation and the capabilities of the drill rig. The accessories which are needed depend upon whether compressed air or drilling mud is used. If drilling mud is used, a settling pit is needed to permit the cuttings to settle before the drilling fluid is recirculated. The design of the settling pit may be very crude or sophisticated. However, portable mud pits which are illustrated in Figures 4-5 and 4-6 have been used with success for geotechnical investigations. If compressed air is used, the upward flow is ejected through a vent at the top of the borehole into a hose to a cyclone or collector buckets. Other accessories which are necessary include low-pressure and/or high-pressure swivels, hoses, and pop-off valves. If the swivel which is mounted on the chucked rod is used for hoisting, it should be heavy duty to ensure that it will not break as the drill string is lowered into or removed from the borehole.

(1) *Circulation of drilling fluid.* Normal circulation of drilling fluid consists of pumping the drilling fluid into the borehole through the kelly and drill string, around the bit, and upward through the annular space between the drill rods and the walls of the borehole. The velocity is high past the drill bit which helps to clean the cuttings from the bit. This method works well for smaller diameter borings. However, for larger diameter borings, the return velocity of the drilling fluid is too small to carry the cuttings to the surface. To enhance the carrying capacity of the drilling fluid, two options are available. Bentonite clay can be added to the drilling fluid to increase its viscosity. Unfortunately, this procedure is unacceptable for certain operations, such as drilling water wells, because the mud cake cannot be easily washed from the walls of the borehole. An alternative procedure is using reverse circulation.

(2) *Reverse circulation of drilling fluid.* The reverse circulation drilling procedure, as the name implies, consists of feeding the drilling fluid into the borehole by gravity and pumping it out through the drill rods. A jet eductor and hoses to connect the eductor to the circulation system are the only additional pieces of equipment which are needed as compared to normal circulation of the drilling fluid. To use reverse circulation, water is pumped from one end of the sump, through the eductor, and returned to the opposite end of the sump. As the water is pumped through the eductor, a vacuum is developed. This vacuum is used to remove the drilling fluid from the borehole by reducing the head of water in the drill rods as compared to the head in the annulus of the borehole. The velocity of the drilling fluid is low in the annulus between the drill rods and the walls of the borehole but is very high inside the pipe. When the reverse circulation method is used, the inside diameter of the drill pipe should be larger than that used for the normal circulation method to permit the cuttings to be carried to the surface.

The reverse circulation procedure is useful for drilling water wells, for drilling cohesionless soils, or for drilling holes 30 centimeters (cm) or 12 inches (in.) diameter (diam) or larger. The lower velocity in the borehole and at the bit tends to cause less damage to the formation. The higher velocity in the drill pipe causes more effective removal of the cuttings from the borehole. However, there are several limiting conditions. The reverse circulation procedure cannot be used if the groundwater table is too high. As a rule of thumb, there must be at least a 2-1/2 m (8 ft) differential between the top of the borehole and the groundwater table to support walls of the borehole. The reverse circulation method does not work well if

cobbles larger than the inside diameter of the drill pipe are encountered. If too many cobbles are encountered and cannot be removed from the boring, the bit should be withdrawn and a bucket auger can be used to clean the bottom of the hole. When clay is drilled, the cuttings may tend to build on the blades of the bit because of ineffective cleaning due to the low velocity of the drilling fluid past the bit. If this problem occurs, the bit cannot be advanced. It must be pulled and cleaned before additional drilling can be done.

c. Drill head. Perhaps the single most important component of the drilling rig is the drive head or drill head. Its primary functions include rotating and hoisting or pull down of the drilling tools. Some drill heads have the capability of being rotated from vertical to horizontal for drilling vertical or inclined holes. Drill rigs may also be equipped with a special “gate opening” drive head which can be swung aside to permit removal of drill rods. The principal disadvantage of this type of drive head is the looseness or wobble which may develop as a result of wear of the system. The gate opening drill head is being replaced with a solid drill head sliding table which can be moved forward or back to permit removal of the drill rods.

Drilling tools are connected to the drill head by a fluted or square thick-walled pipe or “kelly” rod which runs through the drive head. The kelly is designed to move up and down through the drill head as it is rotated. Torque is applied to the kelly through bevel gears in the drive head. The speed of rotation varies over a wide range. The top of the kelly is fitted with a swivel which permits the drilling fluid to be pumped through the kelly and drill rods to the drilling and sampling tools. Some types of swivels have been designed for use in conjunction with the pulldown mechanisms on drill rigs.

Two basic choices for controlling the rate of advance or feed of the drilling or sampling apparatus are available. The screw feed advances the spindle through gears and a feed nut. This technique forces the spindle downward at a set ratio of advance to rotation of the drill string; typically, three or four ratios are available. The hydraulic drive and the chain or cable pulldown techniques are more flexible and reliable and are gradually replacing the screw feed method. In general, with other factors being equal, the hydraulic drive mechanism is capable of developing greater thrusts than chain- or cable-pulldown mechanisms.

(1) *Hydraulic drive.* Oil-operated hydraulic drive systems on drill rigs are the most satisfactory drive mechanisms for conducting undisturbed sampling operations. Most hydraulic drive systems consist of two cylinders which are attached to the drive head. A manual or automatic chuck, which is located in the drive head, consists of three or four jaws which grip the kelly to transfer thrust from the hydraulic cylinders to the drill rods. During drilling operations using a manual chucking system, the hydraulic cylinders are activated to raise the drive head, the kelly is chucked, and a drive is made. When the drive head has been moved a distance equal to the stroke of the hydraulic cylinders, which is usually 0.6 to 0.9 m (2 to 3 ft) of travel, the kelly is unchucked, the cylinders are raised, and the kelly is rechucked for another drive. If an automatic chuck is used, the chuck will only grip the kelly during the downward movement of the drivehead. Figure 3-1 shows a typical truck-mounted rotary drill rig with an hydraulic drive system. Figure 3-2 identifies a number of specific elements, such as cathead, jaw chuck, and rotary table, on a typical truck-mounted rotary drill rig.

(2) *Chain pulldown.* Drill rigs equipped with chain pulldown drive mechanisms are satisfactory for undisturbed sampling of some soils. The chain pulldown system consists of chains located on each side of the kelly which are connected to sprocket wheels located on the deck of the rig. The sprocket wheels are driven through a hydraulic transmission. The chain pulldown mechanism applies thrust through a yoke which is attached to the water swivel at the top of the kelly. Therefore, a special adaptor is required

to allow the piston rod extensions to pass through the swivel and be clamped in the drill rig mast when a fixed piston sampler is used. As compared to hydraulic pulldown systems, chain pulldown systems have a much longer stroke, i.e., 6 m (20 ft) or more. Figure 3-3 shows a truck-mounted rotary drill rig with a chain feed drive system.

(3) *Cable pulldown.* Undisturbed samples are seldom obtained with a cable pulldown arrangement on a drill rig, although cable pulldown mechanisms have sometimes been used to achieve long sample drives. Generally, cable pulldown arrangements are used in remote, inaccessible areas in conjunction with a block and tackle or a hand-operated winch to apply the driving power.

d. *Hoists.* Hoisting drums and cables are needed to raise or lower drilling tools and casing. Hoists on most drill rigs traditionally consist of a single wireline drum with cables and sheaves. These systems are frequently supplemented on a part-time basis by the cathead and rope system or a special wireline hoist for recovering the inner core barrel for wireline drilling.

The typical drum hoist is controlled by a brake and a clutch. The cable on the drum hoist must reach from the hoist to the sheave on the derrick and back to the drill deck. Its advantages include a high gear reduction which allows for powerful, low-speed hoisting capabilities. This feature permits feather smooth lifting characteristics for lowering or raising the drill string without jarring or jerking. However, the drum hoist system is not acceptable for lifting and dropping the hammer for the Standard Penetration Test (SPT) that is discussed in Appendix B (Appendix G of the Geotechnical Investigations manual).

The cathead and rope system is handy for driving casing, lifting and dropping the hammer for the SPT, picking up heavy accessories, and for conducting wash borings. It consists of a cathead, a sheave on a derrick, and a manila rope. This system can be used to lift moderately heavy objects at medium lifting rates.

The wireline hoist system which is used for wireline drilling is a high-speed, low-capacity system. The wireline hoist system must be equipped with sufficient cable to reach from the hoist to the sheave on the derrick to the bottom of borehole.

e. *Derrick.* A derrick is a two- to four-legged frame or mast which is equipped with a sheave for hoisting and handling tools in and out of the borehole. It can also supplement as a frame for stacking drill rods during trips. The design and height of the derrick is usually selected based upon the length of a drill rod and the type of drilling which is normally conducted. For shallow borings, the drill pipe is frequently 3 m (10 ft) sections. For deeper borings, longer drill pipe, i.e., 6 to 9 m (20 to 30 ft), is normally used. For angled holes, a derrick with an adjustable frame or legs may be desirable. Prior to transport, the derrick is folded down on the drill rig; for most rigs, this operation is performed by the use of hydraulic cylinders.

f. *Mounting platform.* With the exception of lightweight portable units which are used in remote areas, drilling rigs are usually affixed to a mounting platform or deck to permit leveling of the drill head before drilling and to prevent movement out of alignment during drilling operations. The platform should be rugged enough to permit the use of the full capacity of the drill.

Several types of drill mounting platforms can be used, depending on the terrain, logistics, and depth of hole. On land, the drill may be mounted on a platform of reinforced timber cribbing or affixed to a truck or trailer. For rugged terrain, a smaller version of the truck-mounted rig may be mounted on skids and dragged. Lightweight units, such as the hand-held vibratory sampling devices or hand-held augers, can

be mounted on casing or a framework of drill pipe which has been driven into the overburden. Land-type drill rigs mounted on barges, floating platforms supported by pontoons of oil drums, or the fixed platforms supported by piles or spuds are used for most nearshore marine work. Although a barge or floating platform is more common than a fixed platform, the disadvantage of the barge or float is that it moves with tide and wave action, whereas the disadvantage of the fixed drilling platform is its expense.

g. Ancillary equipment. A number of small tools and miscellaneous equipment are needed for the drill rig. Driving weights, such as the 63.5 kilogram (kg) or 140 pound (lb) hammer for the SPT test and perhaps a larger hammer, i.e., 113 to 181 kg (250 to 400 lb) range, for driving and removing casing are integral components of the drill rig. Fishing tools for recovering drilling equipment which has been lost in the borehole, bypass and pop-off valves for the fluid circulation system, assorted safety hooks and hoisting tools, tools for coupling and uncoupling drill strings or augers, and spiders and forks for holding sections of drill rods or augers in the borehole should always be carried on the drill rig. A short piece of casing which can be driven into the ground prior to commencing the drilling operations should also be carried on the drill rig; the casing can be used as a collar to prevent erosion or sloughing at the top of the borehole caused by the action of the drilling fluid. Other equipment may include racks for stacking drill rods and samples. A number of small tools such as hand-held hammers, punches, adjustable wrenches, pipe wrenches, pliers, vise grips, screwdrivers, allen wrenches, and hacksaws and hacksaw blades, as well as hard hats, first aid kits, and this manual, should always be carried on the drill rig.

3-3. Types of Drills

Drill rigs are designed to perform a certain type of operation. Rotary, churn, and percussion drill rigs are the most common, although a number of other types of rigs have been designed and developed to perform site-specific tasks, such as drilling shot holes in quarries. Of these rigs, the rotary drill rig is widely used for geotechnical engineering investigations, whereas churn and percussion rigs are used more extensively for drilling water wells and for construction operations, such as drilling holes for cast-in-place piles.

a. Drills for wash borings. The wash boring refers to a process by which the borehole is advanced by a combination of chopping and jetting to break the formation and washing to remove the cuttings. The principal use of the wash boring method is to advance the hole between samples. The cuttings are not acceptable for sampling because of the breakdown of the particles due to the chopping action, the loss of fines during transport of the cuttings to the surface, and segregation of the cuttings in the sump tank. However, an experienced operator may be able to distinguish changes of stratigraphy by the action of the chopping bit as well as by changes of the characteristics of the cuttings.

The equipment to advance holes by the wash boring method consists of a motor which is used to drive a cathead for raising and lowering the tools in the borehole, a derrick with a sheave through which a rope from the cathead is passed to the drilling tools, and a water pump for jetting and washing the cuttings from the borehole. During drilling operations, the drill string is lowered into the borehole. Drilling fluid is pumped under pressure through the drill rods and bit to the bottom of the hole as the chopping bit is raised and dropped. Each time the rods are dropped, they are rotated either manually by a wrench or lever or mechanically by the rotary drill-rig drive. The rotation of the drill rods helps to break the material at the bottom of the borehole. The resulting cuttings are carried to the surface by the drilling fluid which flows in the annulus between the drill pipe and the walls of the hole. Cuttings which are not removed from the borehole when the circulation of the drilling fluid is stopped tend to settle and become the upper part of the next sample. The hole can usually be cleaned satisfactorily by raising the drill string slightly and circulating the drilling fluid until it is free of cuttings. Casing may be used, if necessary, to stabilize the walls of the borehole.

b. Churn drills. The churn drill was one of the first types of drilling machines to be manufactured. Churn drills are used extensively in the water well industry. They are economical to operate and are useful for advancing a boring through boulder or rubble zones and can be used for obtaining disturbed drive samples in soil and soft shale. However, they can not be adapted to undisturbed sampling operations.

The churn drill has no rotary features. Churn drilling which is often called cable-tool drilling is accomplished by the up and down hammering or churning action of a chisel-shaped or a cross-shaped drill bit for spudding or chopping. The drill bit is attached to a heavy steel weight on the drill string which frequently exceeds 450 kg (1,000 lb). The drill string is suspended by a cable and tends to act like a plumb bob when it is raised and dropped. The churning action is accomplished by a walking beam on the drill rig. Churn drills may be truck or trailer mounted and are generally powered by gasoline or diesel engines.

The procedures which are used to advance the borehole depend on the location of the water table and the type of soil which is encountered. Above the water table, a small amount of water should be poured into the borehole to form a slurry with the cuttings. When the carrying capacity of the slurry is reached, it can be removed by bailing. After the cuttings have been removed, more water is added to the borehole and the procedure is repeated. When drilling below the water table, it is not necessary to add water for the slurry. For clays, a small amount of sand may be placed in the borehole to enhance the cutting action of the bit. For sands, clay may be placed in the borehole to enhance the carrying capacity of the slurry. For unstable soils, casing may be added as the borehole is advanced; in soft or cohesionless soils, the borehole can frequently be advanced by bailing inside of the casing. The diameter of the borehole typically ranges from 10 to 30 cm (4 to 12 in.).

To obtain a sample, the drill bit and the short-stroke drilling jar are replaced with a hollow steel barrel and long-stroke fishing jar for drive sampling. The long-stroke jars provide a slip joint link in the drill string that allows the top half of the jar and the drill string to be lifted and dropped while the bottom half of the jar and the sampler remain stationary. Holes which are drilled and sampled tend to be vertical because of the plumb bob action of the drill string.

c. Rotary drills. Rotary drill rigs are the workhorses of most geotechnical engineering drilling and sampling operations. In general, boreholes are advanced by rotary action coupled with downward pressure applied to the drill bit plus the cleaning action of the drilling fluid. Samples may be obtained by rotary coring or by pushing a thin-walled tube into the foundation material at the desired depth. The rated capacity of rotary drill rigs, unless otherwise noted, is usually based on the performance in a 75-mm or a 3-in.-diam (NX) hole. Most drill rigs are mounted on a truck, trailer, tractor, or all-terrain vehicle or on skids, although post-mounted drill rigs or portable units are sometimes used in remote or inaccessible areas.

Most truck-mounted rotary drill rigs can be used for drilling, sampling, and in situ testing. Generally, rotary drill rigs are driven by the power takeoff from the truck engine, although some drill rigs are equipped with independent engines. Two general types of pulldown mechanisms are normally used. Truck-mounted rotary drill rigs equipped with a chain pulldown drive mechanism are capable of drilling to depths of 60 to 300 m (200 to 1,000 ft). Hydraulic feed drive rotary drill rigs are capable of drilling to depths of 150 to 750 m (500 to 2,500 ft). A total thrust capacity of approximately 45 kilonewtons (kN) or 10,000 lb is required for undisturbed sampling in very stiff materials. Although the total thrust on chain pulldown rigs may not be sufficient for undisturbed sampling in resistant soils, these rigs can be used for disturbed sampling and vane shear testing.

In addition to rotary drilling and sampling, rotary drill rigs can be used for bucket-auger drilling and reverse-circulation drilling. For bucket-auger drilling, the rig must be provided with a derrick for lowering and lifting the bucket and an arm to convey the bucket away from the borehole to the dumping area. Telescoping kelly bars and a rotary table opening large enough to pass the bucket permit drilling to depths of 12 m (40 ft) or more without adding extra drill stem. Rigs equipped for reverse circulation must have a large rotary table opening that will allow the passage of 10- to 15-cm- (4- to 6-in.-) diam flange-connected drill pipe.

A number of other types of rotary drill rigs are available, depending on the requirements of the drilling operations. One of the most popular is the skid-mounted rotary drill rig, which is merely a smaller version of the truck-mounted rig. Skid-rigs are powered by air, electricity, diesel, or gasoline. A skid-rig can be moved by its own wireline winch, although the skids are usually arranged for easy mounting on the frame of a truck. Skid-rigs normally employ a hydraulic pulldown drive mechanism and may be equipped with a derrick. Derricks for skid-rigs are lightweight and sometimes can be moved independently of the rig. The drill head can be rotated 360 deg for drilling horizontal or inclined holes. Skid-rigs are used primarily for rock coring, although they may be used for soil sampling in areas inaccessible to trucks. Large rotary drill rigs are usually trailer-mounted and equipped with independent power units. The trailer-mounted rigs are generally less mobile and less convenient for soil sampling than truck-mounted rigs. Tractor-mounted rotary drill rigs may be used in rough terrain, whereas rigs mounted on heavy duty all-terrain vehicles can be used for drilling in marshy and swampy areas. In areas of extremely difficult accessibility, such as nearshore sites and marshy and swampy areas, lightweight post-mounted rotary drill rigs, powered by electricity or gasoline, have been used. For drilling in mines or tunnel shafts and drifts, rigs mounted on double-end bearing posts may be used.

d. Hammer drills. Hammer drilling consists of driving or rotating plus driving a drill to advance the borehole. Hammer drilling is analogous to an air-operated jackhammer with an attached bit. It works well in medium to hard rock that is somewhat friable and brittle. Borings advanced by hammer drilling are satisfactory for taking disturbed samples provided that the material in the bottom of the borehole can be considered as representative. However, undisturbed samples should not be obtained from boreholes advanced by hammer drilling. Hammer drill rigs may be truck-, trailer-, or wagon-mounted. Bits usually have carbide blade inserts or carbide button inserts attached to the cutting edge. The diameter of the boreholes ranges from 10 to 40 cm (4 to 16 in.).

(1) *Becker hammer drill.* A special type of hammer drill, called a Becker hammer drill, was devised specifically for use in sand, gravel, and boulders by Becker Drilling, LTD., of Canada. The Becker hammer drill utilizes a diesel-powered pile hammer to drive a special double wall casing into the ground without rotation. As the casing is driven by the pile hammer, drilling fluid is pumped to the bottom of the hole through the annular space between the two pipes. Either air or water can be used as the drilling fluid. A toothed bit which is affixed to the bottom of the casing is used to break material with blows of the hammer. Broken fragments or cuttings are returned to the surface through the center of the casing. At the surface, the return flow is ejected through a vent in the casing to a hose which leads to a cyclone or to collector buckets. The cuttings which are collected can be observed to give an idea of the materials which have been drilled. If necessary, drilling can be stopped and sampling can be done through the inner barrel using a split-barrel sampler or coring techniques. The outside diameter (OD) of the casing ranges from 14 to 61 cm (5-1/2 to 24 in.).

Figure 3-4 is a photograph of the Becker hammer drill. Figure 3-5 is a schematic of Becker hammer drilling and/or sampling operations using reverse air circulation. A schematic diagram of the double-wall casing with reverse air circulation for removal of cuttings is illustrated in Figure 3-6. Figure 3-7 is a

photograph of several open bits. Typically, the OD of Becker bits ranges from 14 to 23 cm (5.5 to 9.0 in.), although the 17-cm (6.6-in.) diameter is commonly used for the Becker penetration test (BPT). Figure 3-8 is a photograph of a plugged bit which is being connected to the double-wall casing. Plugged bits are used to obtain Becker penetration resistance which is discussed in Appendix C (Appendix H of Geotechnical Investigations manual). Soil, which is collected by a cyclone during drilling operations, is shown in Figure 3-9.

The elements of the Becker hammer drill include an air compressor, mud pump, either a double- or single-acting diesel pile hammer, rotary drive unit, hydraulic hoist, casing puller, mast, and cyclone. The double-wall threaded casing is specially fabricated from two heavy pipes which act as one unit. It has flush joints and tapered threads for making and breaking the casing string. The standard casing is 14.0- to 16.8-cm (5-1/2- to 6-5/8-in.) OD by 8.3- to 8.7-cm (3-1/4- to 3-7/16-in.) inside diameter (ID). The chisel-type bits are made of a tempered steel and nickel alloy. The principal advantage of the Becker hammer drill includes a rapid and inexpensive method for drilling bouldery materials. The principal disadvantage of this method of drilling is that when compressed air is used, the pressure at the bottom of the casing is reduced far below the hydrostatic pressure from the groundwater table. Hence, the flow of groundwater into the borehole can disturb the material at the bottom of the boring. If a boulder is encountered, sand surrounding the boulder may be sucked into casing. As a result, the sample is nonrepresentative, and the recovery ratio could exceed 100 percent.

(2) *Becker CRS drill.* A modification of the Becker hammer drill is the Becker CRS drill. This drill uses twin-tube drill rods with a modified tri-cone roller bit at the bottom of the rods. To advance the borehole, the drill string is hammered and simultaneously rotated. Air is normally used as the drilling fluid, although water or an air-water mixture can be used. The drill bits have an open center to obtain samples. The Becker CRS drill is a fast, economical method for drilling holes or casing through overburden to obtain rock. The Becker processes are patented. Work can be performed under contract with Becker Drilling, LTD.

(3) *Eccentric reamer system.* Another patented hammer drilling system is the eccentric reamer, or ODEX, system. Drilling action consists of rotation plus percussion. The principal drilling equipment consists of a pilot bit with a bearing surface on which the reamer rides and an eccentric reamer which is used to drill the borehole larger than the OD of the casing. Both the reamer and the pilot bit are fitted with carbide cutting inserts for drilling purposes. An eccentrically placed hole in the reamer permits the reamer to be twisted in or out (with respect to the pilot bit shaft), depending on the direction of rotation of the shaft. Stop lugs are used to hold the reamer once it has been positioned. Foam drilling fluid is sometimes used to lubricate the sidewalls of the borehole so that the casing, which follows the bit and reamer, will slide more easily into the borehole. Foam may also enhance the removal of cuttings from the borehole.

Two types of air hammers are available. A downhole hammer is attached directly to the pilot bit. For this system, a special casing shoe is required to transfer the energy from the hammer to the casing to “pull” it down. Center rods which are the same length as the casing sections are used to rotate the pilot bit and reamer during drilling operations. Rotation of the casing is prevented, although the hammer, casing, and drill bits move downward in unison. If a top hammer drive is used, the hammer is attached at the top of the casing string and is connected to the pilot bit and reamer by drill rods. During drilling operations, all components are moved downward in unison. However, only the pilot bit and reamer are rotated; rotation of the casing is prevented.

To operate, the bit is rotated clockwise to swing the reamer to the correct position; a sharp counterclockwise rotation of the drill bit through the drill string swings the reamer back over the pilot bit for removal from the borehole. No samples are obtained by this method of drilling, although a rough idea of the material can be obtained by observing the cuttings. This method of drilling is useful for penetrating loose overburden material to access more competent underlying formations.

e. Auger drills. Auger rigs employ a basic rotary drilling technique in conjunction with various types of augers to advance the borehole. The parts of an auger rig are virtually the same as rotary drilling rigs except a kelly is not needed. The auger is attached directly to the rotary drive or spindle. When an auger rig is needed for rotary work, a chuck is installed above or below the spindle and a kelly rod is inserted through the hollow rotary spindle. Most auger rigs use an hydraulic pulldown drive mechanism. These rigs are usually equipped with long or telescoping hydraulic cylinders which permit a drive or stoke of 1.8 m (5 ft) or more.

Large auger rigs are usually mounted on a crane or truck. Augers and belling buckets are used for drilling large-diameter holes. If a crane is used, no downward force can be applied to the auger. The borehole is advanced by relying on the weight of the bucket plus the digging of the teeth. Drilling operations are controlled from the cab of crane. If a truck-mounted rig is used, drilling operations are controlled from a position on or at the end of the rig. Downward force is applied by a chain or hydraulic pulldown mechanism. During drilling operations, the auger is pulled to the surface after it has been filled. To empty, the drill is pivoted on a turntable on the truck bed. When it has been moved away from the borehole, the auger is spun rapidly to discharge the cuttings.

Small motorized auger drills are used in inaccessible areas. They are useful for obtaining a limited number of holes in a hurry. These drills are handheld or can be mounted on a mobile stand. Most portable drills are capable of reverse augering.

The bucket auger rig, which is a form of the rotary drill rig, uses a ring gear drive to supply rotary torque to the bucket. The ID of the ring must be sufficient to allow the bucket to pass through. The drive bar in which the kelly slides fits into two slots at 180 deg apart on the drive ring. Torque from the kelly is transmitted through the drive bar to the drive ring. For this type of drilling rig, the kelly is usually square with two or three telescoping sections which can be extended to 25 m (82 ft) or more. To fill, the bucket is rotated. When it is full, the bucket is raised and pulled through the drive ring by a cable. A dump arm is used to pull bucket away from the rig. A photograph of a bucket auger drill in operation is presented in Figure 3-10. A variety of types of bucket augers are available for specific tasks. A discussion of the types of buckets is presented in paragraph 7-2d.

f. Other drills. A large number of other drills, including electric arc and electric beam drills, explosive and jet drills, implosion drills, and laser drills are in experimental stages of development and therefore are not discussed herein. Details of these drills are reported by Maurer (1980) and other references. Only those drills which are currently used for civil engineering purposes are discussed.

(1) *Remote control drill.* Drilling by remote control methods has received much interest, especially for investigations of sites such as munitions dumps or areas which are suspected of being contaminated by hazardous or toxic wastes. For remote control drilling operations, air cylinders or electric motors are attached to the operating levers of the rig and to the remote console. The function of the remote control system is to advance or withdraw drilling tools or samplers from the borehole. Other drilling functions such as making or breaking the drill string must be performed by the crew at the rig.

(2) *Electric motor drill.* Electric motor rotary drills are available for use with thin-wall diamond core bits for obtaining samples of concrete and rock from difficult locations. These portable drills can be mounted on a pipe or casing or attached to a rack and base. They can also be bolted to a wall or ceiling, such as in a tunnel or drift. Although these drills are generally not adaptable for soil sampling operations, they can be used to drive small augers. This type of drill is also available in air or gas driven models.

(3) *Air track drill.* Air track drills are used for drilling shot holes in quarries. These maneuverable drills are operated by air motors and move about on steel tracks. They are air-operated and use percussion plus rotary drilling techniques. These drills employ a chain pulldown feed mechanism for advancing the borehole. Air track drills can be used to drill blast holes at any angle.

3-4. Accessories and Appurtenant Equipment

Various types of accessories and appurtenant equipment are required for soil sampling and drilling. This equipment includes, but is not limited to, drill rods, drill bits, casing, portable sumps or mud pits, augers, bailers and sand pumps, and miscellaneous pieces of small equipment. The following paragraphs describe the equipment normally required, excluding hand tools.

It should be noted that a great deal of time and consequently, money can be saved during the actual drilling operations if a little forethought is given to the physical layout of the site and the placement of the equipment in a convenient manner to permit easy access during the drilling operations. Besides the work area required for the drill rig and circulation system, consideration should also be given to the storage and/or stacking of drill rods, casing, and other miscellaneous equipment as well as work areas for inspection, logging, and temporary storage of samples. No standard configurations are offered, however, as the layout of each site is dependent on the equipment involved and the terrain. It is suggested that the driller and engineer or geologist should inspect and plan the layout of the site before drilling begins.

a. Standard nomenclature. Two standards are used for the designation of drilling tools, including drill rods, casing, drill bits, and core barrels. Metric standards predominate in Europe. The Diamond Core Drill Manufacturers Association (DCDMA) standards were developed in United States, Canada, England, South Africa, and Australia. It is estimated that DCDMA standards account for about 80 percent of the equipment which is sold throughout the world (Acker 1974). Therefore, only the DCDMA standards are discussed herein.

A two- or three-letter designation is used to describe drilling equipment according to DCDMA standards (Diamond Core Drill Manufacturers Association, Inc. 1991). The first letter in the DCDMA standard designation, such as E, A, or N, indicates the approximate borehole diameter for standard steel drill pipe. The second letter, i.e., X or W, is the group standardization of key diameters and the design standardization of dimensions affecting interchangeability. For example, "W" is used to designate flush joint casing, whereas "X" is used to designate flush coupled casing. The "X" casing is relatively lightweight tubing with fine threads and is not flush along its ID. The "W" casing is heavier walled than the "X" casing and is machined with coarse threads. It has a box thread at one end and a pin thread at the opposite end. Box and pin threads on tubular members refer to the placement of threads on the inside surface and threads on the outside surface, respectively. The casing is flush along its ID and OD and does not require a coupling. The "W" standard casing is relatively new.

When the three-letter designation is used, the second letter, i.e., X or W, indicates the group of tools with which the equipment can be used. This feature allows for nesting of casing and tools to reach a greater

depth with minimum reduction of the core diameter. In other words, NX core-barrel bits will pass through flush coupled NX casing and will drill a hole large enough to admit flush coupled BX casing, etc. The third letter, i.e., “G,” “M,” or “T,” is the design letter which specifies a standard design, such as thread characteristics. This feature allows for interchangeability of equipment from different manufacturers. Table 3-1 presents a letter size designation with an approximate borehole dimension for drill rods to be used together with casing, core barrels, diamond bits, and reaming shells. Table 3-2 presents nominal dimensions for drill rods, core barrels, bits, casings, and accessories.

b. Drill rods. The principal functions of the drill rods are to transmit the downward thrust and torque from the drill rig to the drill bit and to act as an hydraulic tube for the drilling fluid. Unfortunately, there is very little guidance on the design of drill rods in the DCDMA standards. All that is specified is that the rods must be designed to provide a sufficiently strong torque tube between the drill rig and the drill bit. The drill rod which must also function as a tube to convey the drilling fluid between the drill rig and the drill bit must have a sufficient wall thickness to accept the threads of adjacent rods or equipment and minimize the cross-sectional area to eliminate weight and reduce cost.

To satisfy these requirements, drill rods are frequently designed as upset tubing rather than as parallel wall tubing. Figure 3-11 illustrates upset and parallel wall tubing. The use of upset rods provides sufficient material to accept full threads and thus eliminates unnecessary wall thickness and weight for the drill rods. Most manufacturers also supply cotton rod wicking for the joints of drill rods. The wicking improves the hydraulic seal at the joints and tends to increase the ease of “breaking” or uncoupling the drill string. Another common design feature is left-hand threaded drill rods. Left-hand threaded drill rods are useful with fishing tools for “backing off” drill pipe on equipment lost in the borehole.

N- and NW-size (60-mm (2-3/8-in.) and 67-mm (2-5/8-in.) OD, respectively) drill rods are satisfactory for common soil drilling and sampling operations. Smaller diameter rods are more flexible and cannot withstand large torques, whereas larger diameter drill rods are stiffer and capable of withstanding higher torques but are much heavier. For example, the weight of the N- and NW-size drill rods are 76 and 80 Newtons per meter (N/m) (5.2 and 5.5 lb/ft), respectively, whereas the weight of the HW-size drill rod is 112 N/m (7.7 lb/ft).

c. Drill bits. A variety of bits are available for drilling and sampling operations. The selection of the bit is usually dependent on the formation which is to be drilled and the purpose of the borehole, i.e., a borehole for construction purposes, water well, or obtaining samples as a part of a geotechnical site investigation. The types of bits include those for chopping and percussion drilling in soils and soft rocks and those for rotary drilling in soils and rocks. Drill bits may be made of hardened metal, carbide alloy, or diamond. The material used to construct the bit is related to the intended use for the bit. For example, diamond bits are used for drilling hard, intact formations, whereas carbide-tipped sawtooth bits may be used for drilling softer, fractured formations. A discussion of the use of drill bits in various types of geologic formations for different purposes is presented in the paragraphs which follow.

(1) *Bits for chopping.* A chopping bit is a steel bit which is equipped with a hardened cutting edge. The shape of the bit which is available in common sizes depends on the material to be penetrated. A chisel-shaped bit can be used in sands, silts, clays, and soft rocks for advancing the borehole or for cleaning casing. The star- or cross-shaped chopping bit can be used for drilling and fragmenting coarse gravel, boulders, and rock. They are equipped with upward or downward pointing ports for discharge of the drilling fluid. When used in conjunction with sampling operations, the upward pointing jet is desirable because it causes less disturbance to the underlying material. When used in conjunction with wash

borings, the downward pointing jet is more desirable because the water jet is helpful in eroding the underlying material and suspending the cuttings in a slurry. Heavy percussion drill bits are shaped with a beveled edge for breaking the formation. Several chopping bits are shown in Figure 3-12.

(2) *Bits for rotary drilling.* Both noncoring bits and coring bits may be used in conjunction with rotary drilling operations. Noncoring bits advance the borehole by scraping and shearing chips of material from the intact formation. These rotary drill bits include drag bits, roller bits, and diamond plug bits. Coring bits, in most cases, are merely a modification of a noncoring bit. The principal difference between the noncoring and coring bits is that an annular hole is cut around an intact core by the coring bit. A photograph of several rotary bits is presented as Figure 3-13.

(a) *Non-coring bits.*

(i) *Drag bits.* Drag bits, such as fishtail bits, bladed bits, replaceable blade bits, and carbide insert bits, can be used for drilling soils and soft rock. A photograph of several drag bits is presented as Figure 3-14. The term “fishtail” was originated by Hvorslev (1949). The fishtail bit resembles a straight chopping bit with a split cutting edge. Each half of the chisel-shaped cutting edge is turned slightly in the direction of rotation of the blade. A variation of the fishtail bit is the bladed bit. This type of bit may have two, three, or four blades or wings which have been turned slightly in the direction of rotation. The tips of fishtail and bladed bits are usually made of a tungsten carbide alloy for wear resistance. Replaceable blade bits have insert blades which are individually replaceable. The blades are usually made of a tungsten carbide alloy or hardened metal. Jets are directed at each of the blades for cleaning. An example of a replaceable blade bit is the Hawthorne bit. Carbide insert bits are similar to bladed bits except the edges are not turned. For these bits, an insert is used to form the cutting edge. Carbide insert bits are available with three or four wings. All bits have large passageways for the drilling fluid.

Drag bits can be used for general drilling operations in most soils and softer rocks. Fishtail and bladed bits can be used for cleaning casing, starting holes, or drilling in sands and clays. The fishtail bit may be equipped with baffles to divert the drilling fluid upward or downward. With upward diverted drilling fluid, the fishtail bit is quite suitable for drilling to the top of the soil to be sampled. Finger-type drag bits can be used for general drilling purposes and are satisfactory for advancing boreholes in soils in which a slight disturbance below the bit caused by the jetting action of the drilling fluid is permissible. The configuration of this type of bit makes it impractical to divert the drilling fluid away from the bottom of the hole. Finger-type drag bits are frequently used as the cutting bit for helical augers. However, drilling fluid is not used when auger drilling is conducted. Three- or four-bladed bits are used for drilling in firmer soils, such as hardpan and soft rock.

(ii) *Cone and roller bits.* Cone bits and roller bits are used for drilling materials containing rock lenses, large gravel, and rock formations. Cone-type bits are designed with two or three cones. Roller-type bits consist of two rollers on a horizontal axes and two rollers on an inclined axis; the horizontal rollers are mounted perpendicular to the inclined rollers. These bits have teeth milled on the surfaces of the cones and rollers which rotate as the bit is turned. The spacing and height of teeth is varied for the type of material to be drilled. For softer materials, larger and fewer teeth are used, whereas shorter and more closely spaced teeth are used for drilling harder materials. The teeth are interfaced so they become self-cleaning. Air, mud, or water can be used as the drilling fluid and is discharged at the bottom of the bit. Photographs of typical tri-cone bits are presented in Figure 3-15.

To be used efficiently and effectively, a large downward pressure must be applied to the drill bit. Unfortunately, large downward pressures cannot be supplied by conventional drilling rigs. Nevertheless,

roller bits are used for many geotechnical investigations, especially when harder materials are encountered. In general, the two-cone bit is used for medium soft formations, fractured rock, and cleaning out casing. The three-cone or tricone bits are used for harder rock. Tricone bits provide smoother operation and are more efficient than the two-cone bit. Of these bits, the tricone bit is most frequently used. The costs of tricone bits are greater than the costs of drag bits, although the costs can be offset by a more rapid rate of advancement of the borehole. The principal disadvantage of tricone bits is that these bits cannot be used with great success in materials which contain a large percent of gravel.

(iii) *Diamond plug bits.* Diamond plug bits are noncoring bits which are used in rock formations. The shape of the diamond plug bit is concave, pilot, or taper. The concave bit is least expensive and ideal for drilling in soft rock. The pilot bit has a lead section of smaller diameter and is ideal for drilling hard rock and vertical holes in rock of varying hardness. The point tends to minimize vibrations and hole deviations which allow straight, deep holes to be drilled. The taper-type bit is used for drilling very hard rock and for reaming undersized holes. The shape of the taper bit also tends to minimize vibrations and hole deviations.

(b) *Coring bits.* Coring bits are used for cutting an annular hole around a pedestal of soil or rock to be sampled. Coring bits include diamond bits, carbide insert bits, and sawtooth bits. The selection of a bit is usually based upon the formation or material to be drilled, the cost or availability of various drill bits, and the rate of advancement of the borehole using a particular bit. For example, the cost of a diamond bit for drilling a very hard formation may be offset by a more rapid rate of advancing the borehole. A carbide may be selected for drilling a severely fractured formation; the cost of a damaged carbide bit would be substantially less than the cost of a damaged diamond bit. Diamond bits include the "hand-set" or "surface-set" diamond type and the "diamond-impregnated" type. Hand-set diamond bits are used for drilling very hard, intact materials, whereas diamond impregnate bits are used for drilling more abrasive or fractured materials which would tend to dislodge the diamonds on a hand-set bit. Carbide insert bits can be substituted for diamond bits for most soft to medium-hard drilling operations. Sawtooth bits can be used for soft, fractured, or friable materials.

(i) *Diamond bits.* The selection of a diamond bit should be based upon the experience of the driller and/or the guidance of the manufacturer. When a diamond bit is selected, variables such as the quality and size of the diamonds and the design of the bit, including the face or crown shape, the characteristics of the bit matrix, the number of waterways, the diamond pattern, etc., should be considered. The description of the bit should specify the core barrel size, the core barrel group, design of the core barrel, the grade and size of the diamonds, the type of matrix, and the number of waterways. The description should also indicate whether the diamonds in the drill bit are impregnated or hand set. Additional details of diamond bits can be obtained from the U. S. Army Corps of Engineers (1959), Southwestern Division Laboratory, in a publication entitled "Program for Central Procurement of Diamond Drilling Tools" as directed by Guide Specification CE-1205 and ER 715-1-13. A photograph of a typical diamond coring bit is presented in Figure 3-16.

(ii) *Carbide bits.* Carbide bits can be used in much the same manner and for the same purposes as diamond bits. Two types of carbide bits are available. Standard carbide bits use carbide inserts which are mounted on the cutting edge of the drill bit. Because of the coarseness of the inserts, very large stresses may be exerted on the formation which would tend to disturb or fracture the formation ahead of the bit. Pyramid carbide bits are less likely to chip when subjected to a sharp blow. These bits are suggested for drilling fractured formations. A photograph of a standard carbide insert bit and a pyramid carbide bit is presented in Figure 3-17. In general, carbide bits are less expensive than diamond bits. They have no salvage value and therefore are used to destruction. Since carbide bits are not as hard as

diamonds, they are limited to drilling softer formations or must be used with a slower rate of advance. Frequently, the slower rate of drilling may offset the higher cost of the diamond bit.

(iii) *Sawtooth bits.* A photograph of a sawtooth coring bit is presented in Figure 3-18. This bit is equipped with coarse, hard steel teeth which provide tough cutting surfaces that can withstand a great deal of shock. The sawtooth bit has a high clearance and can be used for drilling hard soil or soft rock provided that a good supply of water is available to remove the cuttings. Abrasion of the steel teeth limits the use of this bit to relatively soft formations. The sawtooth bit is fairly inexpensive.

(c) *Casing bits and casing shoe bits.* The principal differences between casing bits and casing shoe bits are the design. Casing bits have cutting edges on the inner and outer surfaces of the bit. The reduced inside diameter of the casing bit caused by the addition of a cutting surface will not allow the passage of a standard coring bit of the same size or letter. As this characteristic or feature implies, the casing and casing bit must be removed and the casing reset before drilling and sampling through the casing can be conducted. Casing shoe bits are used when drilling through the casing is planned. A cutting surface is not provided on the inside of the bit.

d. *Casing.* Drill casing can be used to stabilize and prevent caving of material into the borehole. Whenever temporary casing is required, a tube with flush inside and outside joints is advantageous and is usually quite simple and economical to make. A metal tube, such as a thick-walled steel pipe, can be cut with a taper on the diameter of about 3 cm/m (3/8 in./ft) and machined with coarse square threads; this design provides a strong flush joint that makes and breaks easily.

Two DCDMA standard series of casing are available. The "X" casing is flush coupled tubing with fine threads. The casing is equipped with box threads at each end; the coupling is equipped with pin threads at each end. The "W" casing is designed with a flush joint and uses coarse threads. It is machined with a pin thread on one end and a box thread on the other end. The principal advantage of the "X" casing is that it is lighter weight than the "W" casing. However, the "W" casing is thicker walled and is more robust than the "X" casing.

Casing can be advanced by driving or "drilling" it to the desired depth. If the casing is driven, the driving hammer, a driving shoe, a driving guide, and an assembly to pull the casing are needed. Drilling the casing into the ground requires the use of a casing shoe or a carbide, sawtooth, or diamond casing bit, depending on the geologic conditions. In addition to the casing and shoe or bit, a water circulation system is also needed to remove material from the casing. It is preferable that the drill is equipped with a hydraulic pulldown drive and has a drill head and spindle which is large enough to pass the casing through the drill head. If the casing will not fit through the drill head, a drill rod and sub can be attached to the casing; this method is tedious because short lengths of casing must be used. Additional information on the placement of casing is presented in paragraphs 6-2b and 8-1b.

e. *Portable sumps.* For rotary drilling operations in which drilling mud or clear water is used, mud pits are needed for capturing the drilling fluid as it is returned from the borehole. The mud pit must also function as a settling pit for the cuttings which are suspended in the drilling fluid. Either portable sumps or dug pits can be used for these purposes. See paragraph 4-4 for a discussion of the requirements of the mud pit. Generally, portable sumps are more convenient and economical than dug pits.

f. *Surface casing.* The function of the surface casing is to minimize the erosion caused by the drilling fluid and to prevent the borehole from "cratering" at the surface. A suitable collar is a short

section of casing, i.e., 0.6 or 1.5 m (2 or 5 ft), which can be driven or spun into the ground before the drilling has commenced.

g. Augers. Augers are used primarily for general exploration, advancing and cleaning the borehole, and drilling accessible borings. Augers are also used for various construction operations, such as drilling drainage wells and excavating for piers and caissons. Disturbed or undisturbed samples can be obtained from boreholes advanced by augering methods. However, disturbed samples may not be representative of the in situ deposit because materials may have segregated during the augering process or may have been contaminated with soils from different depths. The quality of undisturbed samples may also be questionable as a result of stress relief, especially if drilling mud is not used to stabilize the borehole. Augers cannot be used for soils in which the gravel particles or rock fragments are greater than approximately one-tenth of the diameter of the hole.

(1) *Hand-held augers.* Hand-held augers include the Iwan auger, which is commonly referred to as a posthole digger, and small helical augers, such as the ship auger and open spiral or closed spiral augers. The Iwan auger ranges in diameter from 8 to 20 cm (3 to 8 in.) and can be used in stable cohesive or cohesionless soils above the water table. The ship auger is most effective in cohesive materials. It ranges in diameter from 5 to 9 cm (2 to 3-1/2 in.). Open- and closed-spiral augers were developed for soils in which poor recovery was obtained using the ship auger. These augers generally work well in dry clays and gravelly soils. Open- and closed-spiral augers are available with an outside diameter of 5 cm (2 in.). A photograph of Iwan-type posthole augers is presented in Figure 7-1.

The hand-held auger consists of an auger blade attached to one end of a pipe and a crossarm attached to the other end of the pipe. A 2-cm- (3/4-in.-) diam pipe is commonly used although a larger diameter pipe can be used for deep holes. Extensions can be added to the pipe as needed. The maximum depth which can be probed with the handheld auger is about 9 to 10 m (30 to 33 ft). To sample, the auger is rotated as downward pressure is applied. When the blades are full, the auger is withdrawn from the borehole and dumped. For most soils, the sample is satisfactory for identification and classification tests.

(2) *Power augers.* The principal differences between power-driven augers and hand-held augers are the rigidity and robustness of the power equipment and the size and depth of samples which can be obtained. For example, barrel and bucket augers are a modification of the Iwan-type auger. Disk augers and solid- and hollow-stem flight augers are helical augers. Spoon augers are similar to closed-spiral augers. The diameter of power augers ranges from approximately 5 to 244 cm (2 to 96 in.). The depth of samples obtained with power equipment can exceed 30 m (100 ft) or more, depending upon the groundwater conditions and the type of equipment which is used. Barrel, bucket, and flight augers are discussed in Chapters 5 through 8 of this manual.

In general, power augers can be used wherever the borehole is stable and will remain open. The principal disadvantage of sampling by auger methods is that samples are highly disturbed and soils from different strata can be mixed. Because of the potential for mixing of soils from different strata, stratigraphic logging using cuttings from auger borings is extremely difficult. An exception exists, however. When a hollow-stem auger is used, the center plug can be removed at any time and either disturbed or undisturbed samples can be obtained with conventional sampling equipment. Large bucket augers can also be used for drilling large-diameter boreholes which will permit a man to enter and obtain hand-carved samples. The limiting depth for power augering is usually controlled by the power which is required to rotate the auger or the depth to the groundwater table. For continuous flight augers and bucket augers, the limiting depth is about 30 m (100 ft). For short-flight augers, the depth is limited to the length of the kelly on the drill rig, which is about 3 to 6 m (10 to 20 ft), depending on the particular device.

(a) *Bucket augers.* The bucket auger is an open top metal cylinder with one or more slots in its bottom which permit soil to enter as the bucket is rotated and downward pressure is applied. The slots are reinforced and are usually equipped with teeth or a cutting edge. To operate, the bucket auger is attached to the Kelly rod. It is driven by a rotary table. Rotation and downward pressure are used to fill the bucket. When the bucket is full, the rotation is stopped and the bucket is lifted from the borehole. When the bucket is clear of the borehole, it can be emptied by tipping. Some buckets, such as the Vicksburg hinged auger which is shown in Figure 7-2, are equipped with hinges and a trip release which allow the bucket to be opened for dumping. The principal advantage of the bucket auger is the rapid excavation of small- or large-diameter holes to relatively great depths. The principal disadvantage is that most bucket augers cannot be used for drilling cohesionless materials below the water table or to sample gravelly soils.

(b) *Flight augers.* The flight auger is the most commonly used power auger. It consists of one or more flights of helical or spiral fluting attached to a torque bar. Hence, the respective auger is called "single-flight" or "continuous-flight." Likewise, the torque bar may be solid or hollow, which explains the terms "solid-stem" or "hollow-stem." One end of the torque bar is connected to the drill, and the other end can be fitted with a pilot bit and cutting teeth or some other type of bit for ripping the material to be drilled. The spiral fluting acts as a platform for removal of cuttings to the surface.

The diameters of solid-stem flight augers range from 57 mm (2-1/4 in.) to 1.2 m (48 in.), or larger, although flight augers with diameters to 30 cm (12 in.) are the most common. A table of common sizes of flight augers is presented in Chapter 5. The principal advantage of solid-stem flight augers is that a minimum number of tools is required to advance the borehole. These augers can be used for drilling in stable soils, including gravel and soft rock. They do not work well for drilling in hard cemented materials. Solid-stem flight augers cannot be used for drilling cohesionless materials below the water table because the material tends to wash off the auger flights and the holes generally will not remain open.

The hollow-stem auger consists of a section of seamless tube which is wrapped with spiral flight. It is fitted with an adapter cap at its top and a center plug and cutter head at its lower end. The cutter head is connected to the drill rig by drill rods which attach to the adapter at the top of the auger. The cutter head may be equipped with finger-type bits for general drilling, fishtail bits for drilling cohesive materials, or carbide teeth for drilling in hard or stiff deposits. The adapter cap is designed to hold the center plug in place as the auger is advanced. It ensures that the center stem and bit rotate with the auger. When drilling and sampling with the hollow-stem auger, the hole is usually advanced with the center plug and stem in place, although the center plug may be omitted for certain soils. The hollow-stem flights and center stem can be added as necessary. At the desired sampling depth, the center stem and plug can be removed and sampling may be conducted through the hollow stem of the auger. The hollow stem serves as casing.

Two types of connectors are used to connect stems of continuous-flight augers. Screwed joints are easy to connect and form a watertight, rigid, stiff connection. The disadvantages are that the auger cannot be operated in reverse and the stems may be difficult to disconnect, especially if soil particles become wedged in the threads or the threads become worn or damaged. Splined joints transfer torque between auger stems by an octagonal socket and shank jaw coupling or a straight keyed coupling. Tension is transferred by a removable threaded set screw or pin. Splined joints are fairly easy to connect and disconnect, although they may be somewhat difficult to align during assembly. They can also transfer a reverse torque between the auger stems. The principal disadvantages are that the joints are not watertight and must be cleaned regularly before assembly. If O-ring seals are used to effect a watertight seal, the

O-rings must be replaced frequently because of wear. The hollow-stem auger can be used in loose cohesionless deposits below the groundwater table. The ID of hollow-stem augers ranges from about 7 to 30 cm (2-3/4 to 12 in.). The principal advantage of hollow-stem, continuous-flight augers is that the auger serves as a casing for sampling soft or unstable soils. Furthermore, it is likely that less disturbance to the formation is caused by augering than by driving casing. The principal disadvantage of the hollow-stem auger is the cost and size of the equipment which is required to operate the auger. Small tools which are needed for handling auger stems include the auger holding fork shown in Figure 3-19.

h. Bailers and sand pumps. Bailers and sand pumps are used for removing material from boreholes, especially in conjunction with churn and percussion drilling operations. Bailers are fairly easy to operate and are satisfactory for bailing water and soft materials from below the water table in cased boreholes if agitation in the bottom of the borehole is permissible. Where agitation must be minimized, a sand pump should be used. Unfortunately, the cost of a sand pump is greater than the cost of a bailer. The diameter of the borehole made by either of these devices is approximately 2.5 to 5.0 cm (1 to 2 in.) greater than the diameter of the apparatus.

(1) *Sand pump.* A sand pump consists of a tube equipped with a plunger or piston located inside the tube. The bottom of the tube is equipped with a flap or valve for retaining material in the pump. The bottom of the tube may also be equipped with a sawtooth bit, especially if the material must be broken prior to its removal from the borehole. To operate, the plunger is moved up and down to create a suction. The suction causes the slurry and cuttings at the bottom of the borehole to flow into the tube through openings in the sidewall and the bottom. To empty the cuttings from the tube, the plunger is removed and the pump is inverted or the valve must be removed.

(2) *Bailer.* A bailer consists of a pipe with a valve at its lower end and a bail at its upper end. The bail is used to provide a connection for the cable line on the rig which is used to operate the bailer. A valve is needed to retain the material in bailer as it is lifted to surface. Two types of bailers are available.

(a) *Flat valve bailer.* The flat valve bailer is equipped with a flat valve which opens to receive material as the bailer is lowered and closes as the bailer is lifted. To operate, the device is lowered to the bottom of the borehole and then is moved up and down a few inches to create a pumping action. When the bailer is full, it is removed from the borehole and must be turned upside down to empty.

(b) *Dart valve bailer.* The dart valve bailer is equipped with a valve which is shaped like a dart. One end of the valve is a flat plate and the other end is shaped like a cone. To operate, the bailer is dropped to the bottom of the borehole. When the dart strikes the bottom of the boring, the flat plate lifts the cone-shaped valve from its seat and allows slurry to enter the bailer. When the bailer is lifted, the cone-shaped valve drops into its seat to retain the material. To empty the bailer, the dart is touched on the ground which opens the valve. If valve becomes stuck, the bailer can be turned upside down to empty the material.

i. Fishing tools. Whenever a string of drill rods or a drill bit is lost in a borehole, such as when the drill string is dropped or the bit is sheared from the drill rod, tools are used to recover this equipment from the borehole, if possible. A special device, called a fishing tool, is attached to the bottom of a section of drill rod and is lowered to the elevation of the top of the lost equipment. The drill rod is then raised and lowered and hopefully can be used to make contact with the lost equipment.

Two types of fishing tools are available: a spear or tap and a die or overshot. The spear is a long, slender pointed tool with tap threads on its periphery. When the spear has been seated in the drill rod, it

is rotated until the threads grip the rod. The die or overshot is analogous to a funnel with die-type threads on its inside. This tool is slipped over the drill rod and rotated until the threads grip the rod.

j. Miscellaneous hand tools. Miscellaneous hand tools, such as hoisting plugs or swivels, foot clamps and holding irons, and assorted wrenches are needed for assembling or disassembling and lifting or lowering the drill string or casing. A hoisting plug, which is shown in Figure 3-19, is a ball-bearing type swivel which is used for lifting or lowering the rods or casing. Foot clamps and holding forks may be used to suspend the tools and drill string in borehole. Foot clamps are more widely used than holding irons, although they are used less extensively in conjunction with wireline drilling. Holding irons take less time to set up than foot clamps, although it is more likely that the drill string may be dropped into the borehole when holding irons are used. Assorted wrenches are needed to assemble and disassemble the drill rod and drilling tools. Pipe wrenches can be used for drill rods or casing, chain wrenches or tongs are frequently used for larger diameter pipe and casing, and strap wrenches are used for polished tubing and bits. Parmalee wrenches should be used for double tube core barrels.

Table 3-1
First Letter Hole Size Relationships for Compatibility of Drilling Equipment (After Diamond Core Drill
Manufacturers Association, Inc. 1991)

| Letter | Hole Diameter | |
|--------|---------------|--------|
| | Millimeters | Inches |
| R | 25 | 1 |
| E | 40 | 1-1/2 |
| A | 50 | 2 |
| B | 65 | 2-1/2 |
| N | 75 | 3 |
| K | 90 | 3-1/2 |
| H | 100 | 4 |
| P | 125 | 5 |
| S | 150 | 6 |
| U | 175 | 7 |
| Z | 200 | 8 |

**Table 3-2
Nominal Dimensions for Casing and Accessories (after Diamond Core Drill Manufacturers Association, Inc. 1991) (Continued)**

| Size
Designation | Drill Rod | | Rod
Coupling | Flush Coupled | | | Flush Joint
Casing | | Casing Bit | | Casing Core
Shoe Bit | | Core
Bit | Core
Barrel | Diameter |
|----------------------------|------------|------------|-----------------|---------------|------------|------------------------|-----------------------|------------|------------|------------|-------------------------|------------|-------------|----------------|------------|
| | O.D.
mm | I.D.
mm | I.D.
mm | O.D.
mm | I.D.
mm | Coupling
I.D.
mm | O.D.
mm | I.D.
mm | O.D.
mm | I.D.
mm | O.D.
mm | I.D.
mm | O.D.
mm | O.D.
mm | O.D.
mm |
| E ^{2,3} | 33.3 | 22.2 | 11.1 | ---- | ---- | ---- | ---- | ---- | ---- | ---- | ---- | ---- | ---- | ---- | ---- |
| A ^{2,3} | 41.3 | 28.6 | 14.3 | ---- | ---- | ---- | ---- | ---- | ---- | ---- | ---- | ---- | ---- | ---- | ---- |
| B ^{2,3} | 47.6 | 31.7 | 15.9 | ---- | ---- | ---- | ---- | ---- | ---- | ---- | ---- | ---- | ---- | ---- | ---- |
| N ^{2,4} | 60.3 | 50.8 | 25.4 | ---- | ---- | ---- | ---- | ---- | ---- | ---- | ---- | ---- | ---- | ---- | ---- |
| RX | ---- | ---- | ---- | 36.5 | 30.2 | 30.5 | ---- | ---- | 37.7 | 25.4 | 37.7 | 30.1 | ---- | ---- | ---- |
| EX | ---- | ---- | ---- | 46.0 | 41.3 | 38.1 | ---- | ---- | 47.6 | 35.7 | 47.6 | 38.0 | ---- | ---- | ---- |
| AX | ---- | ---- | ---- | 57.2 | 50.8 | 48.4 | ---- | ---- | 59.6 | 45.2 | 59.6 | 48.3 | ---- | ---- | ---- |
| BX | ---- | ---- | ---- | 73.0 | 65.1 | 60.3 | ---- | ---- | 75.3 | 56.3 | 75.3 | 60.2 | ---- | ---- | ---- |
| NX | ---- | ---- | ---- | 88.9 | 81.0 | 76.2 | ---- | ---- | 91.8 | 72.1 | 91.8 | 76.0 | ---- | ---- | ---- |
| HX | ---- | ---- | ---- | 114.3 | 104.8 | 100.0 | ---- | ---- | 117.4 | 95.9 | 117.5 | 99.7 | ---- | ---- | ---- |
| RW ³ | 27.8 | 18.3 | 10.3 | ---- | ---- | ---- | 36.5 | 30.5 | 37.7 | 25.4 | 37.7 | 30.1 | ---- | ---- | ---- |
| EW ³ | 34.9 | 25.4 | 11.1 | ---- | ---- | ---- | 46.0 | 38.1 | 47.6 | 35.7 | 47.6 | 38.0 | ---- | ---- | ---- |
| AW ³ | 44.5 | 34.9 | 15.9 | ---- | ---- | ---- | 57.2 | 48.4 | 59.6 | 45.2 | 59.6 | 48.3 | ---- | ---- | ---- |
| BW ⁴ | 54.0 | 44.5 | 19.1 | ---- | ---- | ---- | 73.0 | 60.3 | 75.3 | 56.3 | 75.3 | 60.2 | ---- | ---- | ---- |
| NW ⁴ | 66.7 | 57.2 | 34.9 | ---- | ---- | ---- | 88.9 | 76.2 | 91.8 | 72.1 | 91.8 | 76.0 | ---- | ---- | ---- |
| HW ⁴ | 88.9 | 77.8 | 60.3 | ---- | ---- | ---- | 114.3 | 100.0 | 117.5 | 96.0 | 117.5 | 101.0 | ---- | ---- | ---- |
| PW | ---- | ---- | ---- | ---- | ---- | ---- | 139.7 | 127.0 | 143.5 | 117.7 | 143.5 | 123.2 | ---- | ---- | ---- |
| SW | ---- | ---- | ---- | ---- | ---- | ---- | 168.3 | 152.4 | 172.5 | 143.1 | 172.5 | 150.8 | ---- | ---- | ---- |
| UW | ---- | ---- | ---- | ---- | ---- | ---- | 193.7 | 177.8 | 198.1 | 171.6 | 198.1 | 175.4 | ---- | ---- | ---- |
| ZW | ---- | ---- | ---- | ---- | ---- | ---- | 219.1 | 203.2 | 223.9 | 197.0 | 223.9 | 202.6 | ---- | ---- | ---- |
| EWG | ---- | ---- | ---- | ---- | ---- | ---- | ---- | ---- | ---- | ---- | ---- | ---- | 37.3 | 36.5 | 21.4 |
| AWG | ---- | ---- | ---- | ---- | ---- | ---- | ---- | ---- | ---- | ---- | ---- | ---- | 47.6 | 46.0 | 30.0 |
| BWG | ---- | ---- | ---- | ---- | ---- | ---- | ---- | ---- | ---- | ---- | ---- | ---- | 59.5 | 57.9 | 42.0 |
| NWG | ---- | ---- | ---- | ---- | ---- | ---- | ---- | ---- | ---- | ---- | ---- | ---- | 75.3 | 73.8 | 54.7 |
| HWG | ---- | ---- | ---- | ---- | ---- | ---- | ---- | ---- | ---- | ---- | ---- | ---- | 98.8 | 95.2 | 76.2 |
| EWM | ---- | ---- | ---- | ---- | ---- | ---- | ---- | ---- | ---- | ---- | ---- | ---- | 37.3 | 36.5 | 21.4 |
| AWM | ---- | ---- | ---- | ---- | ---- | ---- | ---- | ---- | ---- | ---- | ---- | ---- | 47.6 | 46.0 | 30.0 |
| BWM | ---- | ---- | ---- | ---- | ---- | ---- | ---- | ---- | ---- | ---- | ---- | ---- | 59.5 | 57.9 | 42.0 |
| NWM | ---- | ---- | ---- | ---- | ---- | ---- | ---- | ---- | ---- | ---- | ---- | ---- | 75.3 | 73.8 | 54.7 |
| RWT | ---- | ---- | ---- | ---- | ---- | ---- | ---- | ---- | ---- | ---- | ---- | ---- | 29.4 | 28.5 | 18.6 |
| EWT | ---- | ---- | ---- | ---- | ---- | ---- | ---- | ---- | ---- | ---- | ---- | ---- | 37.3 | 36.5 | 22.9 |
| AWT | ---- | ---- | ---- | ---- | ---- | ---- | ---- | ---- | ---- | ---- | ---- | ---- | 47.6 | 46.8 | 32.5 |
| BWT | ---- | ---- | ---- | ---- | ---- | ---- | ---- | ---- | ---- | ---- | ---- | ---- | 59.5 | 58.7 | 44.4 |
| NWT | ---- | ---- | ---- | ---- | ---- | ---- | ---- | ---- | ---- | ---- | ---- | ---- | 75.3 | 73.8 | 58.7 |
| HWT | ---- | ---- | ---- | ---- | ---- | ---- | ---- | ---- | ---- | ---- | ---- | ---- | 98.8 | 96.8 | 80.9 |
| 2-3/4 X 3-7/8 ⁵ | ---- | ---- | ---- | ---- | ---- | ---- | ---- | ---- | ---- | ---- | ---- | ---- | 97.5 | 92.0 | 68.3 |
| 4 x 5-1/2 ⁵ | ---- | ---- | ---- | ---- | ---- | ---- | ---- | ---- | ---- | ---- | ---- | ---- | 138.0 | 133.3 | 100.8 |
| 6 x 7-3/4 ⁵ | ---- | ---- | ---- | ---- | ---- | ---- | ---- | ---- | ---- | ---- | ---- | ---- | 194.4 | 184.1 | 151.6 |
| AQ ⁶ | 44.5 | 34.9 | ---- | ---- | ---- | ---- | ---- | ---- | ---- | ---- | ---- | ---- | ---- | 48.0 | 27.0 |
| BQ ⁶ | 55.6 | 46.0 | ---- | ---- | ---- | ---- | ---- | ---- | ---- | ---- | ---- | ---- | ---- | 60.0 | 36.5 |
| NQ ⁶ | 69.9 | 60.3 | ---- | ---- | ---- | ---- | ---- | ---- | ---- | ---- | ---- | ---- | ---- | 75.7 | 47.6 |
| HQ ⁶ | 88.9 | 77.8 | ---- | ---- | ---- | ---- | ---- | ---- | ---- | ---- | ---- | ---- | ---- | 96.0 | 63.5 |

¹ For casing, the minimum physical strength characteristics are 450 MPa (65,000 psi) yield stress and 550 MPa (80,000 psi) tensile stress.

² Old standard, but still in use on some projects.

³ Parallel wall rod. The minimum physical strength characteristics are 450 MPa (65,000 psi) yield stress and 550 MPa (80,000 psi) tensile stress.

⁴ Upset end drill rod. The minimum physical strength characteristics are 275 MPa (40,000 psi) yield stress and 415 MPa (60,000 psi) tensile stress.

⁵ Large design core barrels; 69.9 mm by 98.4 mm, 101.6 mm by 139.7 mm, 152.4 mm by 196.9 mm, respectively.

⁶ Wire line size designation (after Longyear 1981). Drill rod serves as casing and drill rod. Core bits and core diameters vary slightly according to the manufacturer.



Figure 3-1. Truck-mounted rotary drill rig with a hydraulic drive system

- A HYDRAULIC DRIVE CYLINDERS
- B HYDRAULIC PISTON ROD
- C JAW CHUCK
- D ROTARY TABLE
- E CATHEAD
- F FIXED PISTON SAMPLER
- G PISTON ROD EXTENSION
- H DRILL ROD
- I SOIL ANCHORS

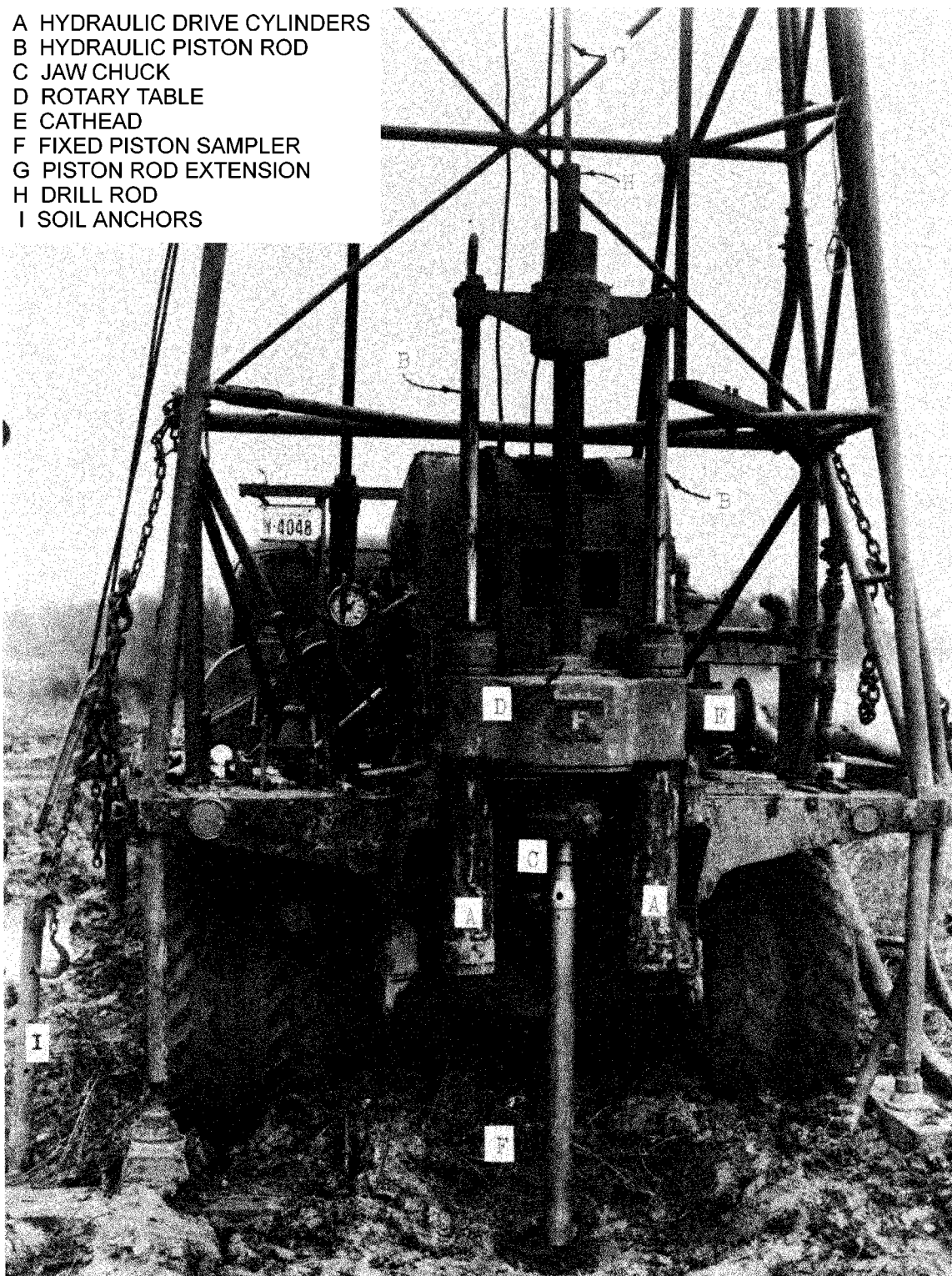

Figure 3-2. Photograph of a truck-mounted rotary drill rig with specific features of the drill rig identified

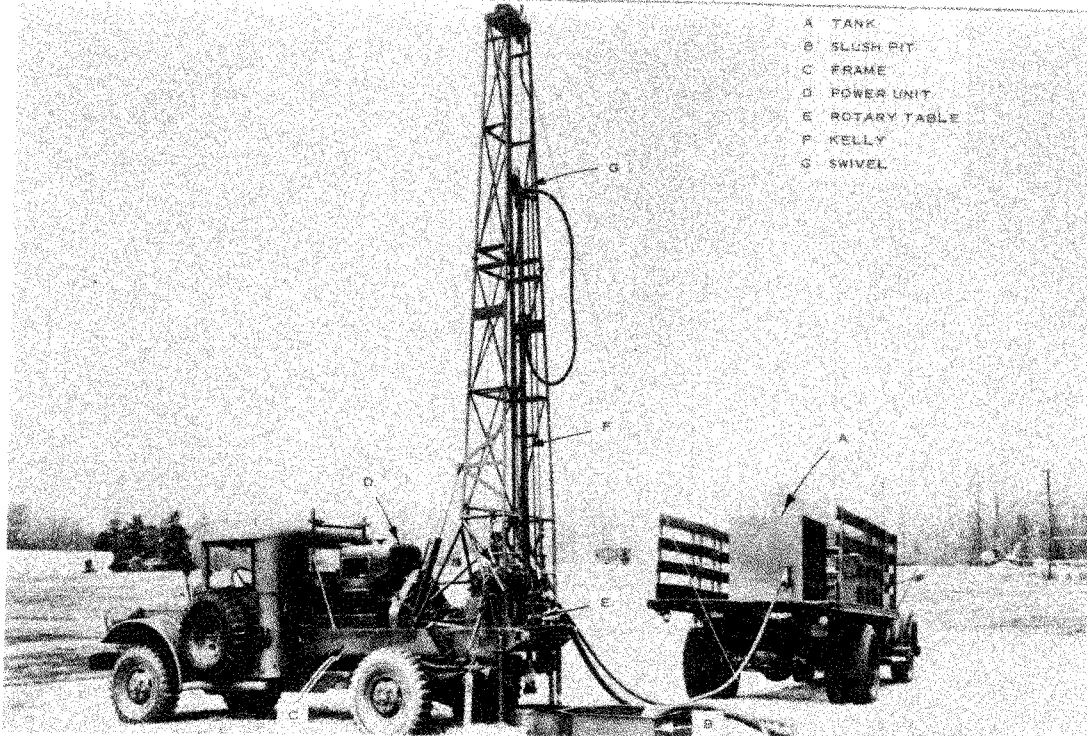

Figure 3-3. Truck-mounted rotary drill rig with a chain feed drive system

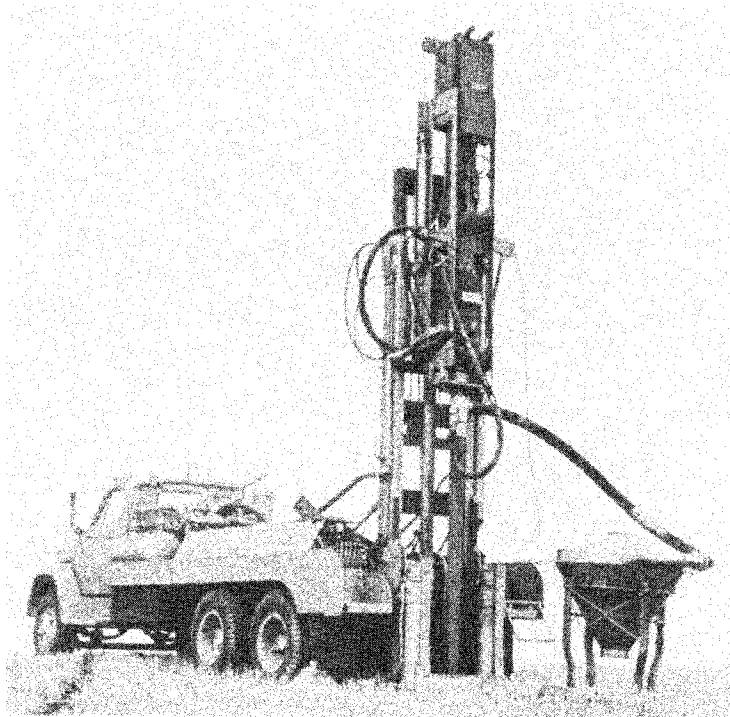

Figure 3-4. Photograph of a Becker hammer drill

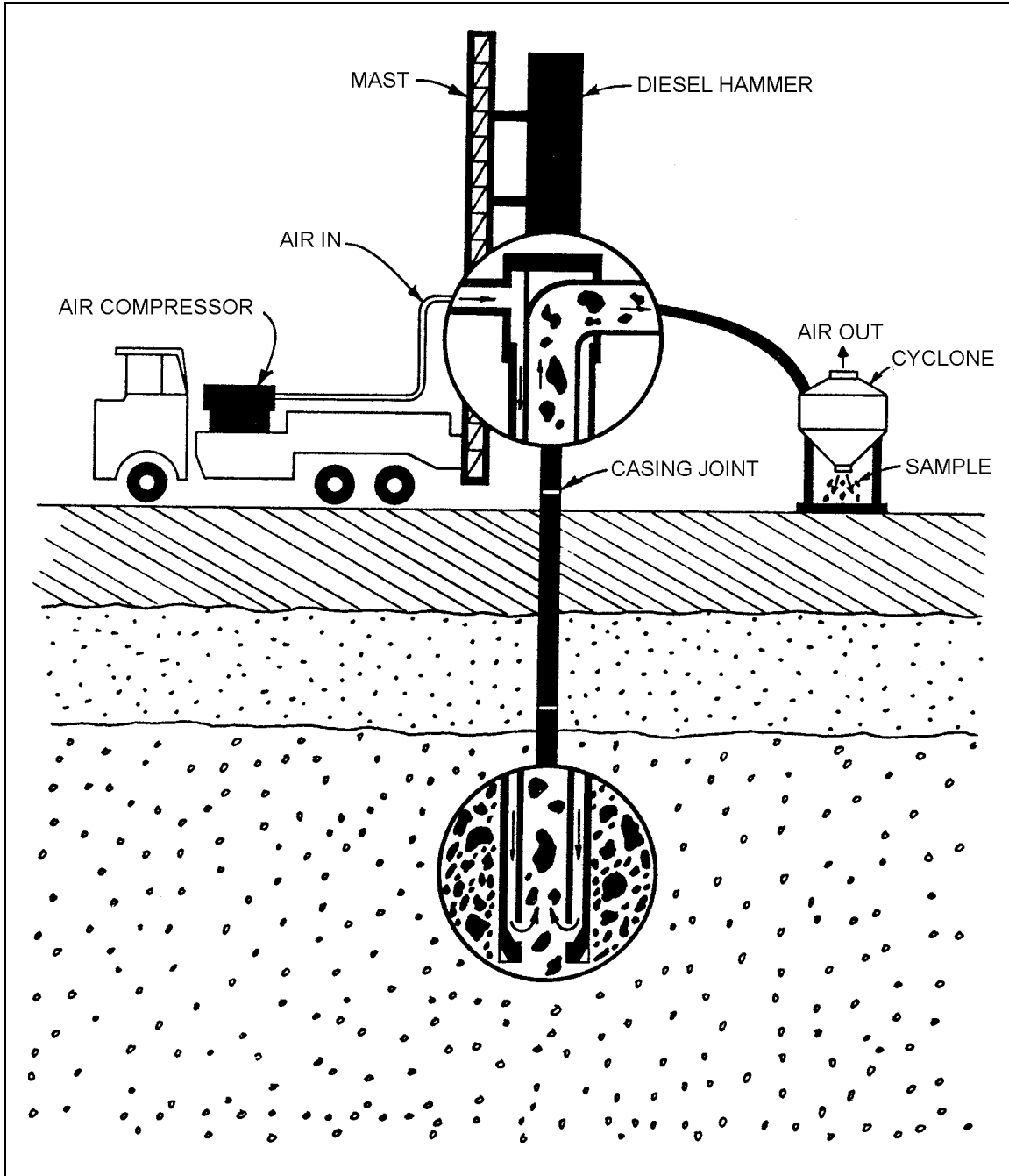

Figure 3-5. Schematic of Becker hammer drilling and/or sampling operations using reverse air circulation (Harder 1993)

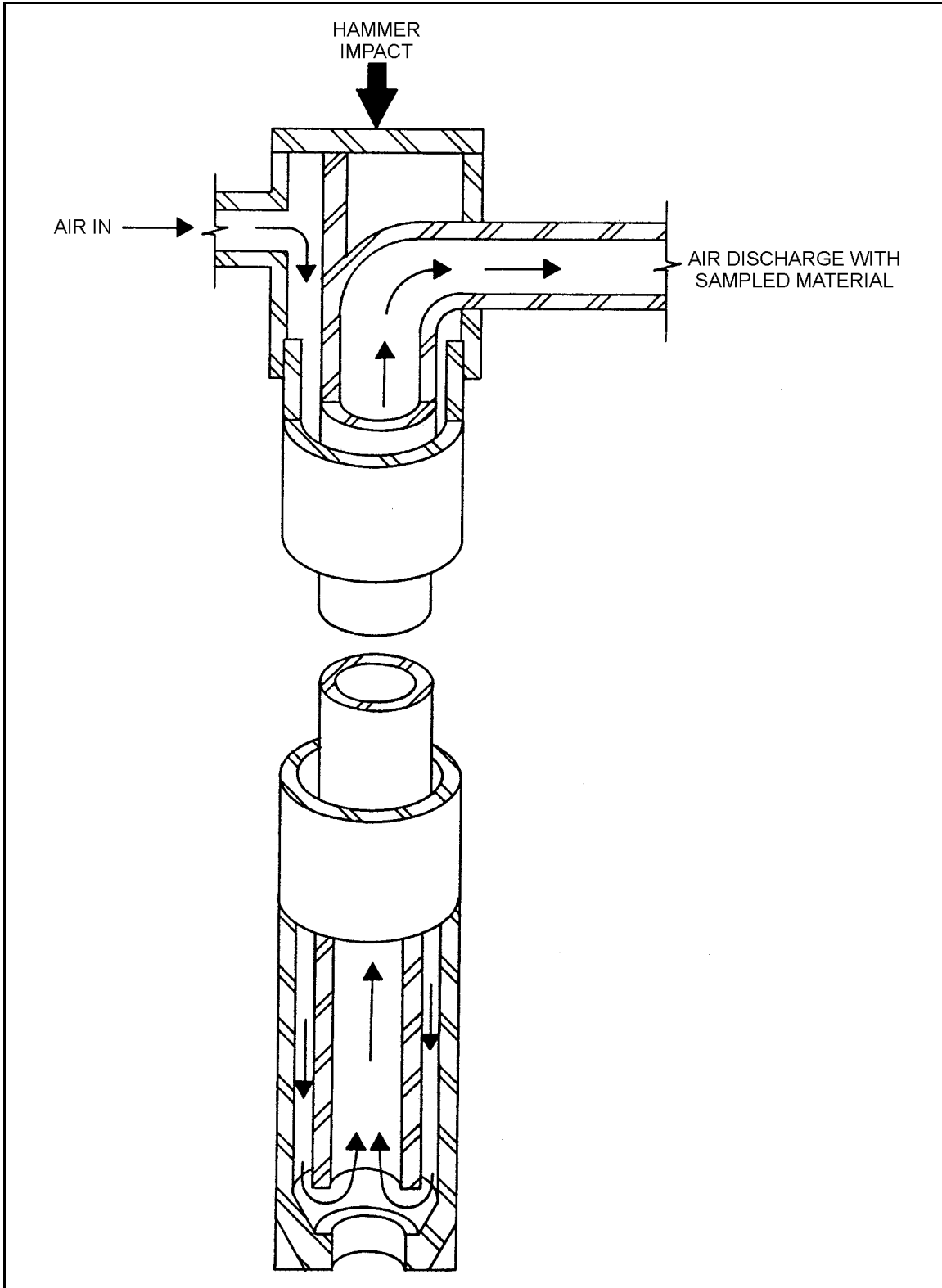

Figure 3-6. Isometric diagram of the double-wall casing with reverse air circulation for removal of cuttings (Harder 1993)

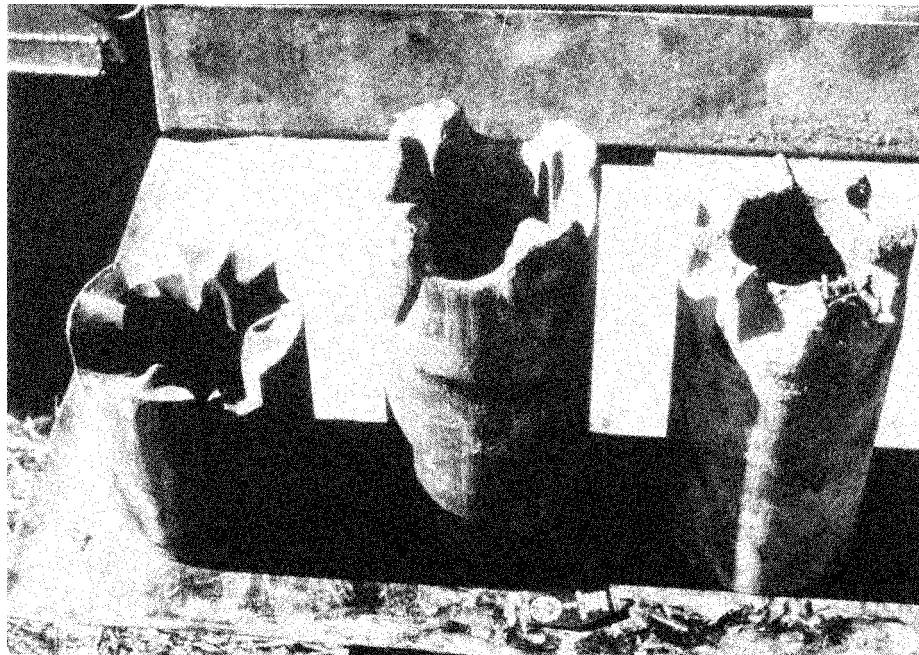

Figure 3-7. Photograph of several open-type Becker bits (Harder 1993)

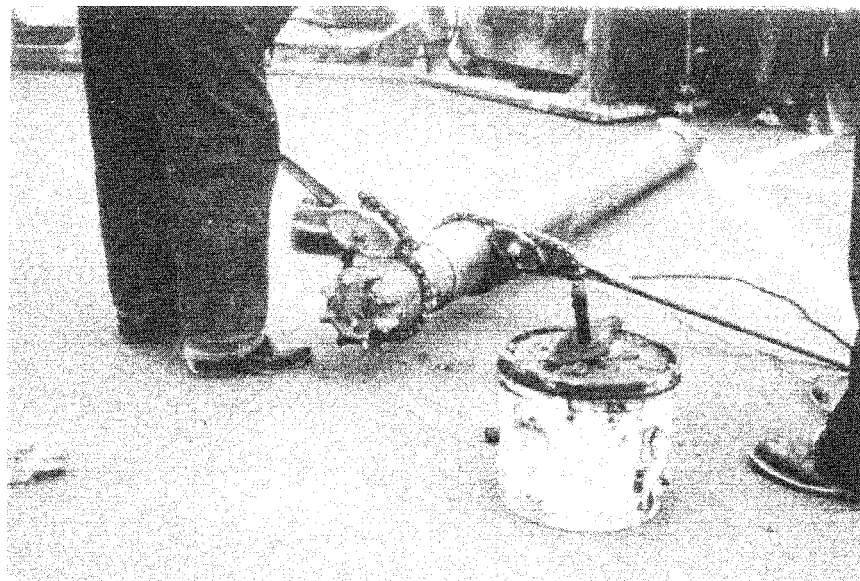

Figure 3-8. Photograph of a plugged bit which is used to obtain Becker penetration resistance (Harder 1993)

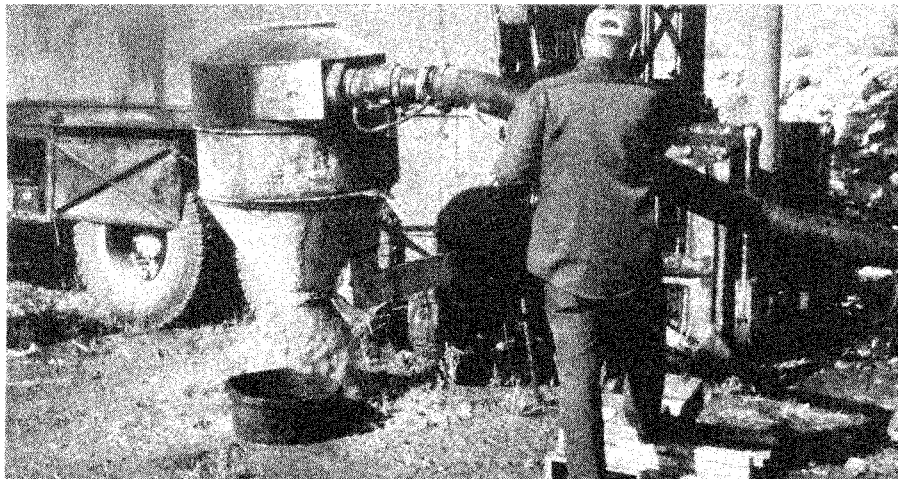

Figure 3-9. Soil is collected by a cyclone during Becker hammer drilling operations (Harder 1993). Note: Safety is a very important consideration for Corps of Engineers projects. Safety items, including hardhats, gloves, safety shoes, protective clothing, and dust or vapor masks, should be worn, as appropriate, for the particular drilling and sampling operations

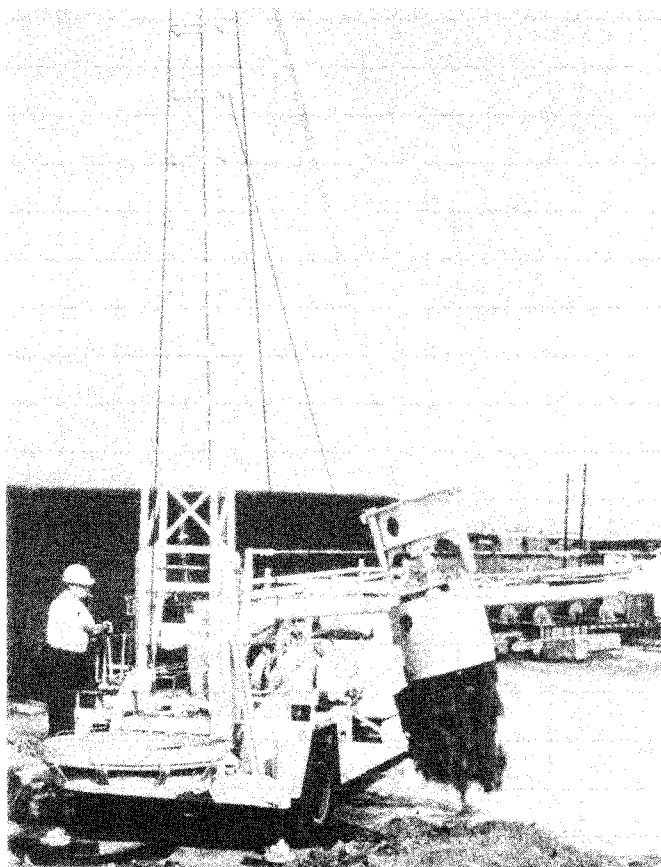

Figure 3-10. Photograph of a bucket auger drill in operation

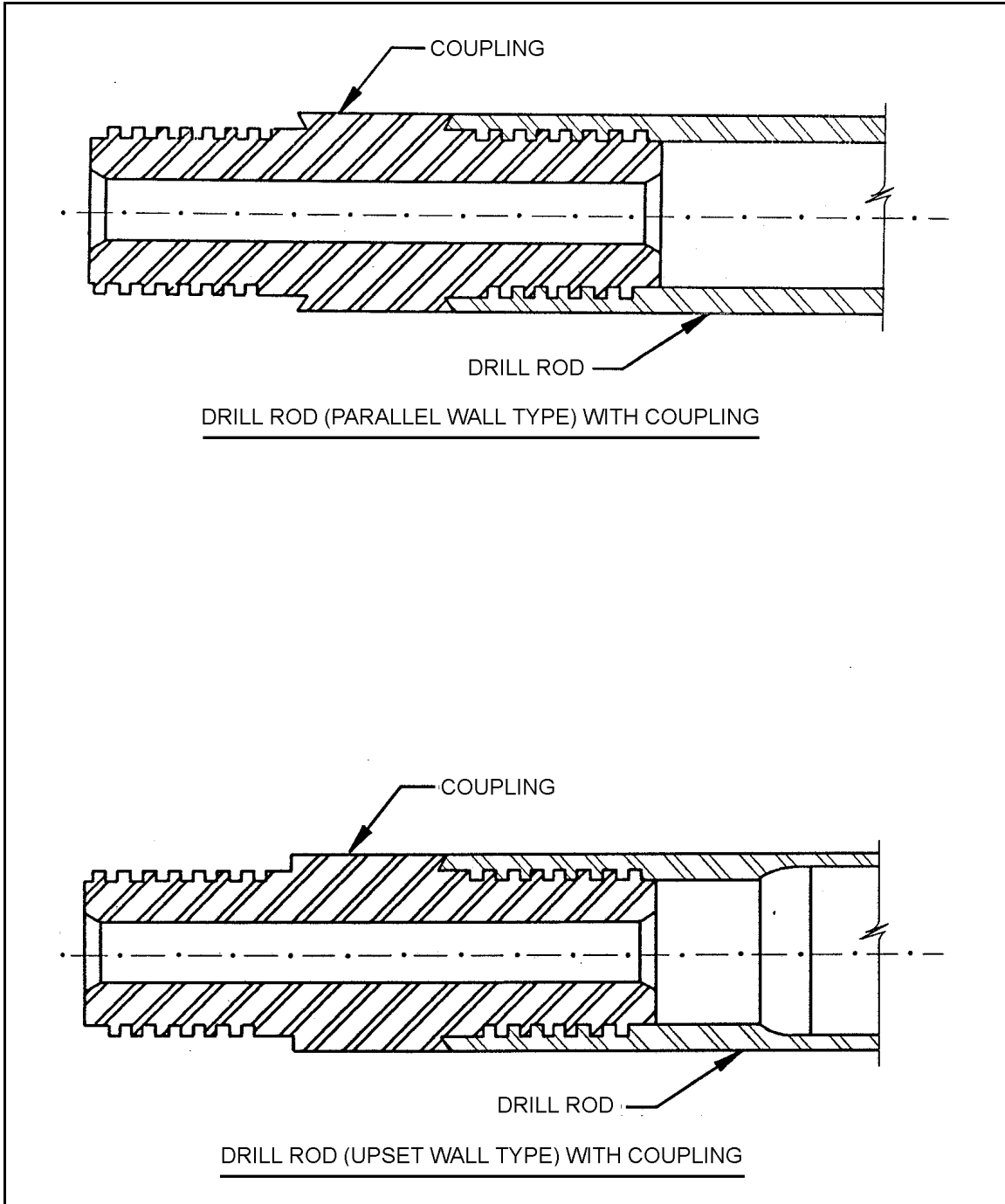

Figure 3-11. Cross sections of drill rods which illustrate upset and parallel wall tubing (after Hvorslev 1949)

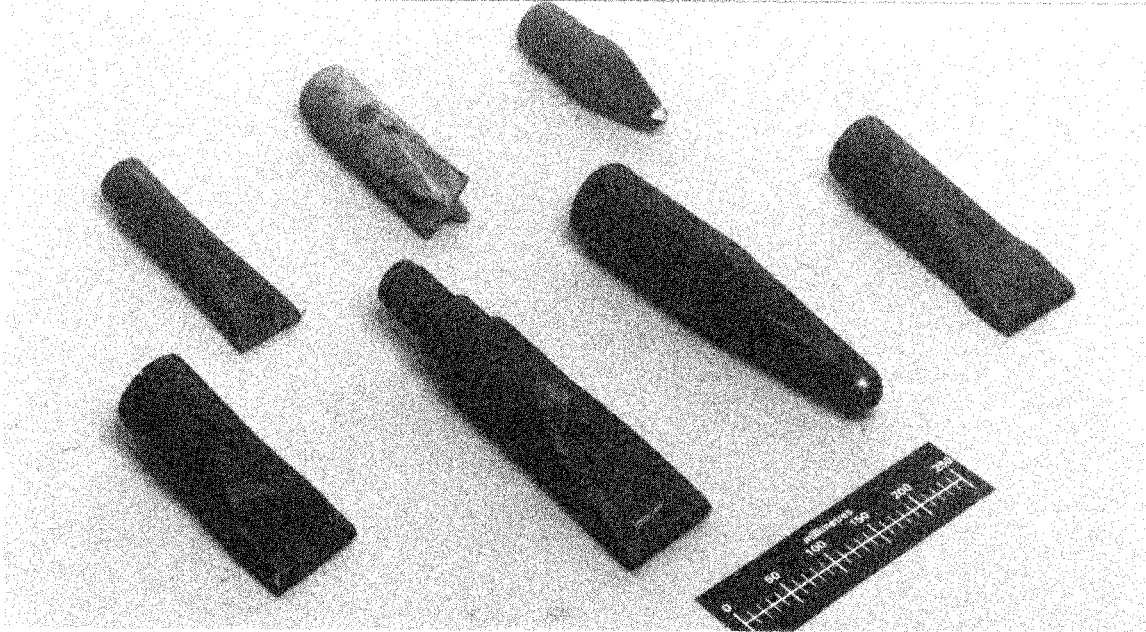

Figure 3-12. Photograph of several chopping bits

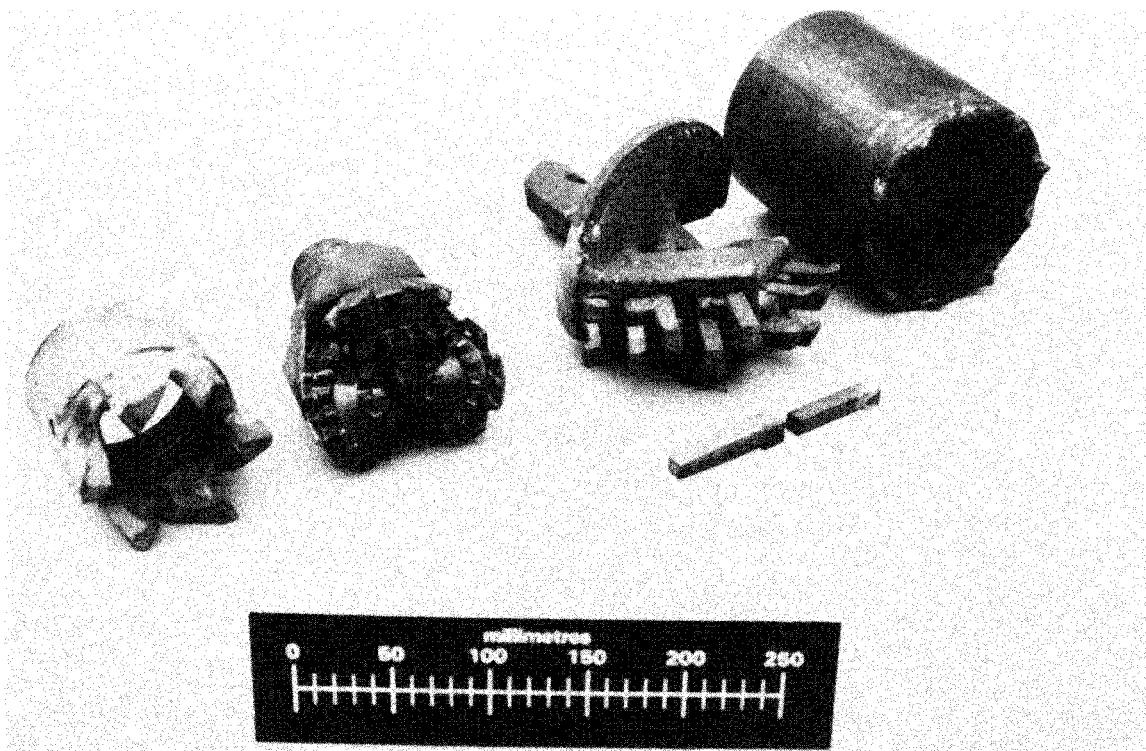

Figure 3-13. Photograph of several rotary bits

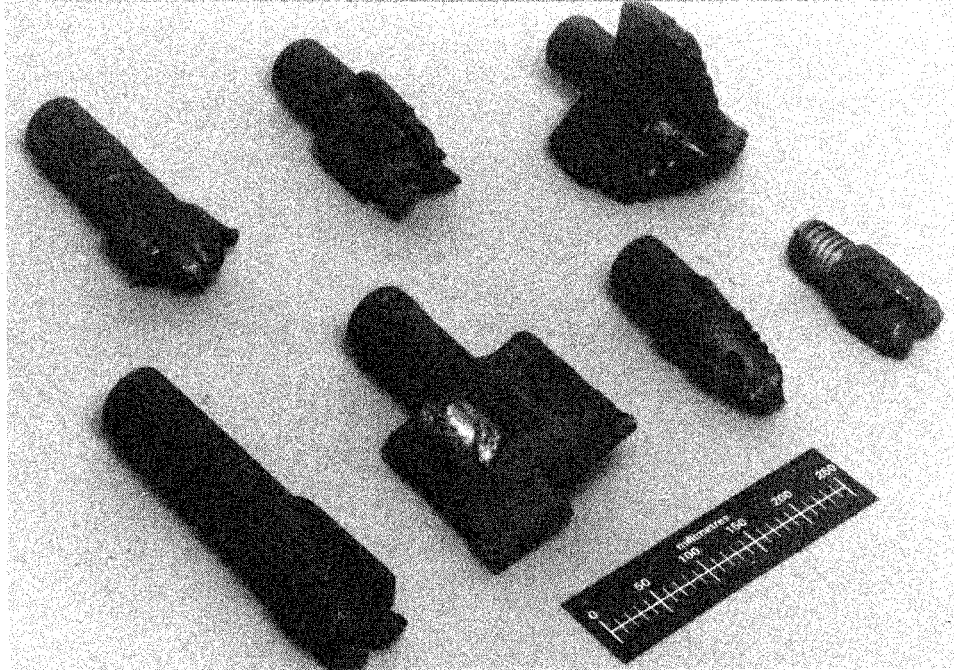

Figure 3-14. Photograph of several drag bits

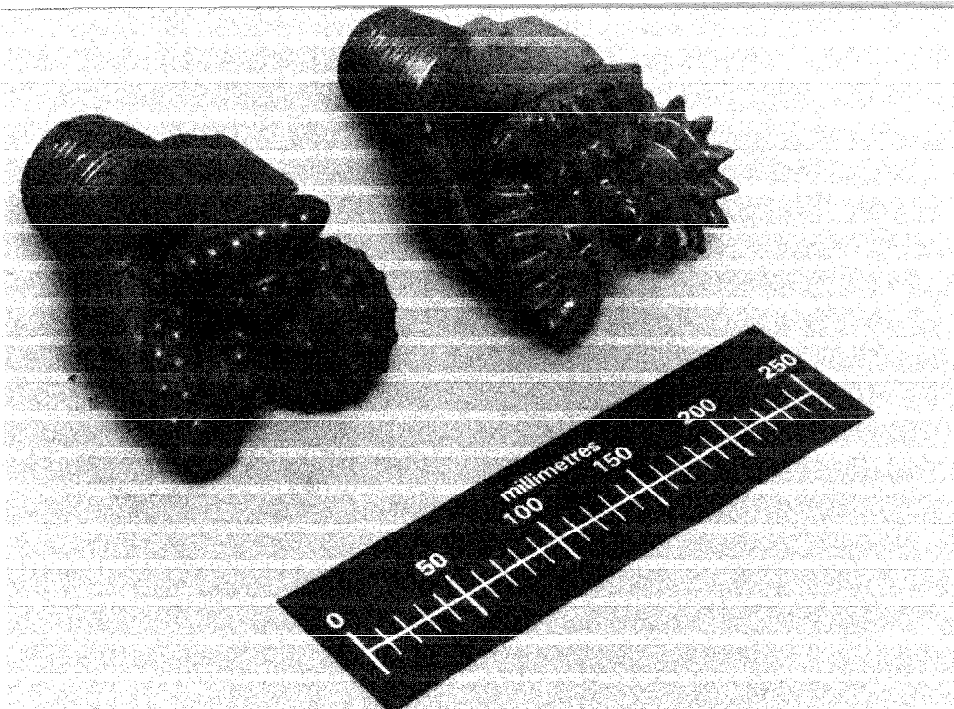

Figure 3-15. Photograph of typical tri-cone bits



Figure 3-16. Photograph of a typical diamond coring bit



Figure 3-17. Photograph of a standard carbide insert bit and a pyramid carbide bit

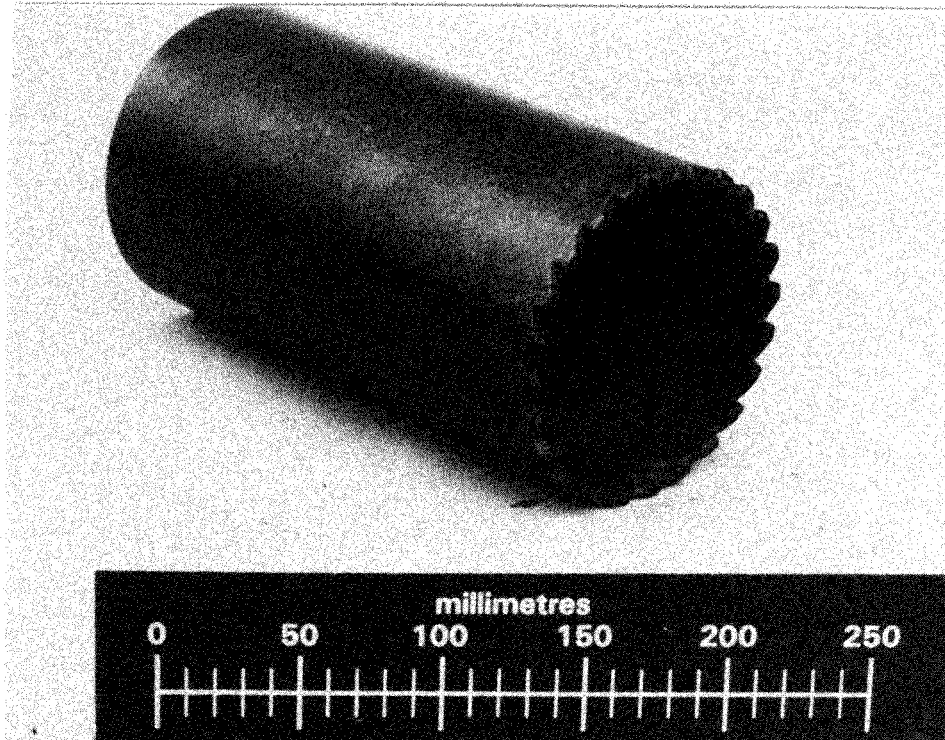

Figure 3-18. Photograph of a sawtooth coring bit

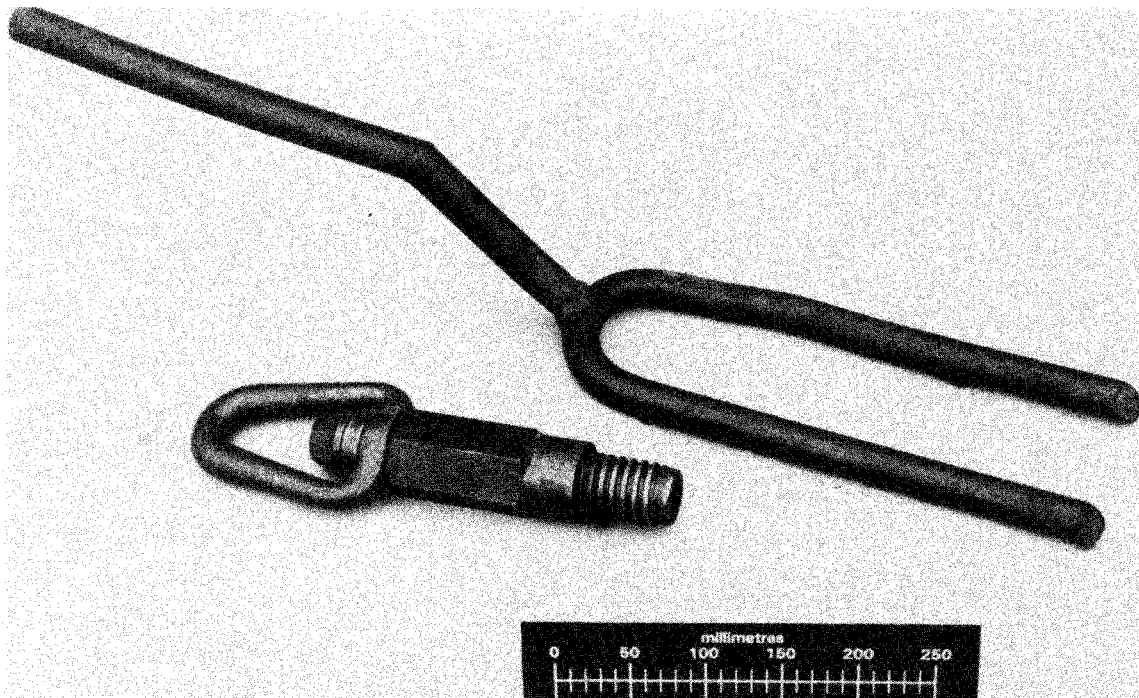

Figure 3-19. Photograph of a holding fork and a hoisting plug

Chapter F-4 Drilling Fluids

4-1. Purpose of Drilling Fluids

Most rotary drilling methods, with the exception of augering methods, require the use of drilling fluids. Drilling fluids perform several functions. The primary functions include cleaning the cuttings from the face of the drill bit, transporting the cuttings to the ground surface, cooling the drill bit, lubricating the drill bit and drill rods, and increasing the stability of the borehole. In addition, there are a number of secondary functions. Some of the more significant secondary functions are suspending the cuttings in the hole and dropping them in surface disposal areas, improving sample recovery, controlling formation pressures, minimizing drilling fluid losses into the formation, protecting the soil strata of interest, facilitating the freedom of movement of the drill string and casing, and reducing wear and corrosion of the drilling equipment.

4-2. Types of Drilling Fluids

Nearly all of the Corps of Engineers drilling and sampling is accomplished using one or more of four general types of drilling fluid: compressed air, foam, clear water, and water-based mud. Air and water generally satisfy the primary functions of a drilling fluid. However, additives must often be added to these fluids to overcome specific downhole problems. Air with additives is referred to as “foam.” A freshwater- or saltwater-based drilling fluid with additives is commonly called “drilling mud.” A fifth type of drilling fluid is the oil-in-water emulsion or oil-based mud. However, this category of drilling fluids is not commonly used for geotechnical engineering investigations and therefore is not discussed herein.

a. Compressed air. Compressed air is a very effective drilling fluid for drilling in dry formations in arid climates, in competent consolidated rock, or in frozen ground. Only minor modifications to a conventional drilling rig and drill bits are required to drill with compressed air as compared to drilling with mud. An air compressor with its complement of pressure gauges, safety valves, storage tank, etc., is required. A delivery hose is needed to connect the air supply to the kelly of the drill rig. A deflector should be placed over the borehole to deflect the cuttings which are brought to the surface by the compressed air. When drilling frozen formations, refrigeration equipment may be required to chill the compressed air before it is pumped into the borehole, especially if the ambient temperature is warmer than about -5 deg C (23 deg F). If the relative humidity is high, provisions should also be made for defrosting the chiller.

Conventional drill bits may be used for drilling most formations with air. Drag bits have been used to drill soft to medium formations, frozen fine-grained soils, and ice. Roller bits generally have performed satisfactorily in medium to hard formations. However, it has been found that larger discharge nozzles may be required to drill with air as compared to drilling with water or mud.

Both air pressure and volume of air are important for the successful use of air as the drilling fluid. The effective use of air as a drilling fluid requires a high volume of air to efficiently remove cuttings from the hole. High pressure alone will not assure a sufficient volume of air and could damage the formation. In general, a low-pressure, i.e., 350 kilopascals (kPa) or 50 psi, high-volume capacity compressor is more economical and desirable than a high-pressure, low-volume system.

The minimum annular uphole velocities must be varied for each drilling condition encountered. Annular velocities on the order of 20 to 25 m/sec (4,000 to 5,000 ft/min) with upper limits of 45 m/sec (9,000 ft/min) have been found to be satisfactory for many materials. The higher upward velocities should be used cautiously as they may tend to erode the walls of the borehole. Equation 4-1 can be used to estimate the size of the air compressor which will produce the appropriate volume of air:

$$Q = \frac{V (D_h^2 - d_o^2)}{12.732} \quad (4-1)$$

where

Q = compressor capacity, dm³/sec

V = air return velocity, m/sec

D_h = borehole diameter, cm

d_o = drill pipe outside diameter, cm

Once the flow rate or compressor capacity has been selected, the pressure requirements should be checked to ensure that the compressor will meet the minimum requirements and that the pressure ratings of the pipes and fittings will not be exceeded. The pressure range for the compressor can be estimated from Equation 4-2 (O'Neil 1934):

$$p_g = \frac{Q (T_1)^{0.5}}{3.5366 d_i^2 C} - 101 \quad (4-2)$$

where

p_g = gauge pressure, kPa

Q = compressor capacity, dm³/sec

T_1 = upstream temperature (absolute, deg F)
= 459.7 + [1.8 × (upstream temperature, deg C) + 32]

d_i = inside diameter of drill pipe or coupling, cm

C = coefficient of flow; use 0.65 for sharp-edged orifices

An example of the use of Equations 4-1 and 4-2 follows. The upward velocity of air required to carry the cuttings to the surface was estimated to be 25 m/sec (5,000 ft/min). The diameter of the borehole was assumed to be 19.7 cm (7.75 in.); this value corresponds to the OD of the 15.2- by 19.7-cm (6- by 7-3/4-in.) core barrel. It was also assumed that flush coupled NW drill rods would be used. The OD of NW drill rods is 6.668 cm (2.625 in.), the ID is 5.715 cm (2.250 in.), and the ID of the couplings is 3.493 cm (1.375 in.). The upstream air temperature was estimated as 20 deg C (68 deg F). Using the

values of $V = 25$ m/sec (5,000 ft/min), $D_h = 19.7$ cm (7.75 in.), and $d_o = 6.668$ cm (2.625 in.), the minimum compressor capacity was determined to be 675 dm³/sec (1,430 ft³/min) according to Equation 4-1. Using values of $T_1 = 20$ deg C (68 deg F or 527.7 deg absolute) and $d_i = 3.493$ cm (1.375 in.), the gauge pressure was determined by Equation 4-2 as 452 kPa (65 psi).

If the compressor capacity calculated according to Equation 4-1 or the pressure calculated according to Equation 4-2 is approximately equal to the capacity of the compressor or the piping, a more rigorous determination of these parameters should be conducted before the acquisition and mobilization of the equipment is initiated. It should be noted that leaks, head losses, frictional warming of the air, etc., were not considered for the example. It was also assumed that the smallest orifice was the ID of the coupling. However, it is probable that smaller orifices, such as fluid ports on the drill bit, would constrict the flow of compressed air. Therefore, consideration of all aspects of drilling with air should be addressed before the design of the system is finalized. A number of references on compressed air technology are available in the literature.

Compressed air has several advantages over other types of drilling fluids. Generally, air more efficiently cleans the drill bit which extends its life, probably as a result of less grinding of the cuttings. Although rotary bit speeds are practically identical to drilling with water and muds, air drilling is usually faster than mud drilling due in part to the increased weight (approximately 20 percent) on the drill bit. However, in softer formations the penetration rate must be reduced to prevent squeezing around the bit and blocking fluid ports. Accurate logging of material changes can be easily noted as the cuttings, which generally vary from a fine powder to the size of a thumb nail, are uncontaminated. For example, during an investigation of a landslide, subtle changes of moisture content can be more easily detected using compressed air than when using water or drilling mud. When formations containing expansive clays and shales or gypsum are drilled using air, water is not used and therefore cannot be imbibed by the soil. When the drilling is in cavernous material, the expense of lost circulation of drilling muds is eliminated. In cold climates, the potential of freezing the drilling mud is eliminated when compressed air is used as the drilling fluid.

The use of compressed air for the drilling fluid also has disadvantages. Core drilling with air may present specific problems because of constrictions in the flow path, i.e., the head of the core barrel, past the bit, and past the small annular area between the core barrel and the wall of the hole, especially if coring systems designed for use with water are used. When drilling is in caving formations, too large an annulus may result; the return velocity of the air will decrease and may become inadequate to lift the soil cuttings. Air works best as a drilling fluid when free water is not present in the material being drilled; however, dust suppression may be required to prevent the adverse health effects of breathing the expelled dust, especially when drilling is in siliceous materials and in confined areas such as drainage and grouting galleries. The presence of water in the hole or from cuttings of wet but not saturated clay or shale formations reduces the capacity of the air to carry cuttings from the hole and often causes the cuttings to ball and cling to the drill bit, drill rod, and walls of the borehole. When this condition occurs, the chance of the drilling tools getting stuck in the hole is increased. Moreover, the pressure at the bottom of the borehole may be increased sufficiently to fracture the formation. Consequently, the use of air for drilling most clays and shales is not recommended.

b. Foam. Foam or mist may be added to compressed air to enhance its performance, especially when too much water is encountered when air drilling formations such as clays and shales. Foam will help keep the cuttings separated, reduce the effects of balling and sticking, assist in removing water from the drill hole, and allow larger cuttings to be removed from the hole with the same volume of air. Because the removal of larger cuttings from the bottom of the hole is enhanced and thus helps to assure better cleaning of the hole, faster bit penetration due to less grinding of cuttings and longer bit life result.

Foam is also used as a dust suppressant and will reduce air loss, which allows drilling through lost circulation zones.

Foaming agents are generally biodegradable mixtures of surfactants. During drilling operations, a mixture of the foaming agent and water is injected into the compressed air stream between the compressor discharge and the top of the hole at a rate of 1,000 to 2,000 dm³/hr (265 to 530 gal/hr), although this rate may be adjusted for the conditions encountered. The foam ranges from a mist of as little as 0.25 dm³ (1/2 pint) foaming agent per 380 dm³ (100 gal) of injection water to a stiff foam consisting of a mixture of bentonite slurry and/or organic polymer, water, and foaming agent. The foam mist is generally adequate to suppress dust, combat small water inflow, and remove sticky clay, wet sand, and fine gravel in holes with few hole problems. Stiffer foam is required as the hole diameter and depth increase, gravel or cuttings become larger, water inflows become significant, or unstable hole conditions are encountered. Injection of mist or foam may require an increased return velocity of 30 percent or more as compared to strictly air drilling. Because foam drilling is not commonly used in Corps of Engineers activities, it is recommended that anyone planning to use foam drilling should investigate available products and manufacturer's recommendations.

c. Clear water. Water is generally a cost-effective and efficient drilling fluid which has been used for numerous drilling operations. The drilling fluid is formed naturally by mixing clear water with cuttings of soil from the formation which is being drilled. In some instances, such as the drilling of formations in which temperatures are naturally at or slightly above 0 deg C (32 deg F), ice water or a brine of ice water and salt may be used as the drilling fluid.

Drilling with clear water has several attributes. Cuttings drop easily from suspension. Clear water is preferred when bedrock core drilling for dam site investigations or hydraulic pressure testing is required. Water losses or gains during drilling are excellent qualitative indicators of zones of potential seepage and zones which require grouting. If pressure tests are to be conducted, water in joints, fractures, or bedding planes is less likely to influence the apparent permeability of the formation as compared to the effects of drilling mud. If geotechnical strength tests are to be made on cores, water may be less likely to alter the apparent strength along preexisting discontinuities than drilling muds which may have constituents with lubricating qualities. Clear water may be used where formation water pressures are normal or subnormal, although it does not work well in highly permeable or water-sensitive formations.

Water alone is a poor hole stabilizer, may cause clays and shales to swell, does not suspend cuttings well when the pump is shut off, and offers minimal lubrication and no control of fluid loss. Therefore, it is often imperative that certain inorganic or organic constituents be added to water to control the properties of the drilling mud, such as weight or density, viscosity, and filtration characteristics, which better satisfy drilling needs.

d. Water-based muds. These fluids are the workhorses of most geotechnical drilling and sampling operations. The most common additive to form a water-based mud is bentonite, although polymers have been developed and perform well for most drilling operations. These drilling fluids plus appropriate additives fulfill all primary and secondary purposes listed in paragraph 4-1. The primary disadvantages of using drilling mud are: a large volume of drilling fluid (water) is required, and a high potential for hole erosion exists. As a rule of thumb, the volume of mud required to drill a hole is approximately three times the volume of the hole. The flush or return velocity of the drilling fluid coupled with its viscosity is potentially hazardous to erodible materials in boreholes.

Uphole mud velocities which are required to carry cuttings from the boring vary as a function of the size and density of the cuttings and the viscosity and weight or density of the drilling mud. Typical uphole

velocities range from 0.2 to 0.7 m/sec (40 to 140 ft/min). Equation 4-1 may be used to size the mud pump capacity.

(1) *Bentonite mud.* Bentonite is the most commonly used drilling fluid additive and consists of finely ground sodium bentonite clay. When mixed with water, the resulting slurry has a viscosity greater than water, possesses the ability to suspend relatively coarse and heavy particles, and tends to form a thin, very low permeability cake on the walls of the borehole. Because of these attributes, bentonite drilling mud is superior to water as a drilling fluid for many applications. Bentonite for drilling is generally available in a standard grade which complies with the American Petroleum Institute (API) Specification 13A (American Petroleum Institute 1983). A high yield grade, which contains organic polymers, generally produces approximately the same viscosity as the standard grade with one-half the amount of bentonite. It should be noted, however, that the standard grade bentonite may contain peptizing agents and organic additives. For environmental drilling where additives are unacceptable, pure sodium bentonite is available from several suppliers.

(2) *Polymer mud.* Both natural and synthetic organic polymers are available that will produce drilling muds with desirable properties. Although the cost of most polymer additives is greater than the cost of bentonite, the lubricating quality of many polymer muds is excellent and can noticeably reduce bit and rod wear. As compared to bentonite muds, polymer muds often contain a lower solids content. Although polymer muds may lack the gel strength which is required to suspend particles or to form a satisfactory filter cake as compared to bentonite muds, polymer muds can be pumped at much higher viscosities. Consequently, the water loss due to poorer filter cake properties is partially mitigated by reduced seepage of the very viscous mud into the formation. A natural polymer, which has been used for drilling wells and piezometers, is made from the Guar bean; it degrades naturally because of the action of enzymes and returns to the viscosity of water within a few days.

(3) *Bentonite/polymer mud.* It is sometimes advantageous to prepare drilling muds composed of both bentonite and polymer with water. The low solids viscosity properties of organic polymers when combined with the filtration properties of a bentonite mud yields a mud with excellent characteristics for many applications. When the combination mud is prepared, the bentonite should be added to the water before the polymer is added.

4-3. Properties of Water-Based Muds

Drilling muds have four basic properties that determine the behavior of the mud as a drilling fluid: viscosity, density, gel strength, and filtration. Several other properties, although of lesser importance, need to be checked, especially if problems are anticipated or encountered. These properties include sand content, pH (alkalinity or acidity), and calcium content (hard water). Although tests are available to measure each of these properties, simple field tests for viscosity and density, coupled with an understanding of drilling and the capabilities of available mud products, can satisfy the drilling needs for most geotechnical investigations.

Table 4-1 summarizes each property, its desirable limits and control, and its influence on drilling operations. Table 4-2 is a summary of additives/chemicals which can be mixed with drilling mud to control properties or minimize/eliminate problems encountered during drilling operations. Although these tables give a general overview of desirable drilling mud properties, special problems may require technical assistance from drilling mud manufacturing companies.

a. Viscosity. Viscosity is defined as the resistance offered by a fluid (liquid or gas) to flow. The thicker a particular fluid is the higher its viscosity. Accurate measurement of the viscosity of drilling

mud is dependent on a number of factors and requires special equipment. The basic factors which affect the viscosity of a mud are the viscosity of the base fluid (water); the size, shape, and number of suspended particles; and the forces existing between particles as well as between particles and the fluid.

For field applications, a qualitative viscosity measure can be obtained by the Marsh funnel, which is shown in Figure 4-1. The funnel viscosity is the time in seconds for 1 quart (0.946 dm³) of mud to pass through the Marsh funnel, expressed as seconds per quart (sec/qt). To determine the viscosity using the Marsh funnel, hold the funnel in an upright position and place a finger over the outlet. Pour the test sample, which has just been taken from near the pump suction end of the mud pit, through the screen into top of the funnel until the level of drilling mud just reaches the bottom of the screen. Place a cup under the funnel outlet. Remove the finger from the outlet and time the number of seconds for one quart of fluid to flow from the funnel into the cup. The number of seconds is recorded as the funnel viscosity. If available, a stopwatch should be used for measuring the time. The usual range of Marsh funnel viscosities for good effective bentonite mud is 32 to 38 sec/qt (34 to 40 sec/dm³); for polymer muds, funnel viscosities of 40 to 80 sec/qt (42 to 85 sec/dm³) are reasonable. For comparison, the funnel viscosity of fresh water is 28 sec/qt (30 sec/dm³) at 20 deg C (68 deg F).

As a general rule, viscosity should be maintained as low as possible to provide the required hole stability and water loss control. Thin mud does the best job of cleaning the bit and optimizing the drilling rate, but thick muds are needed to remove coarse gravel from the hole. Marsh funnel viscosity readings should be taken routinely and recorded on the boring log.

For most drilling operations, acceptable limits can be obtained by adding approximately 22.7 kg (50 lb) of bentonite per 375 dm³ (100 gal) of water. Because the characteristics of the additives of polymer muds are quite different than those of bentonite, the solids content of polymer mud is much lower than the solids content of bentonite mud of the same viscosity. Natural clay muds which occur as a result of drilling with clear water are inferior to bentonite muds in their ability to increase viscosity. Much more clay is needed to achieve a given viscosity; the resulting mud will have a higher density and generally poorer qualities than a bentonite drilling mud has.

b. Density. Density is defined as the weight per unit volume of drilling fluid. It is commonly reported as kilograms per cubic meter (kg/m³) as well as pounds per gallon (lb/gal) or pounds per cubic foot (pcf). The desired density, which is frequently incorrectly called weight, for most drilling situations is usually less than 1,080 kg/m³ (9.0 lb/gal) and can be easily determined by a mud balance which is shown in Figure 4-2.

To determine the density of the drilling fluid with the mud balance, fill the cup to capacity with fresh, screened mud. Place the lid on the cup and rotate the lid until it is firmly seated. Make sure that some drilling mud is squeezed out the vent hole. Wash or wipe the excess mud from the exterior of the balance. After the exterior surface of balance has been dried, seat the balance with its knife edge on the stand and level by adjusting the rider. Read the mud density from the inside edge of the rider as indicated by the marker on the rider. Any of the scales on the rider may be used to express the mud density, although kilograms per cubic meter or pounds per gallon are the most commonly used scales. The calibration of the mud balance can be easily checked by filling the cup with fresh water. It should read 1,000 kg/m³ (8.34 lb/gal).

An increase in density of the drilling mud is a measure of how much drilled material is being carried in suspension and recirculated. Excess suspended solids are objectionable for several reasons. First, the cuttings are generally abrasive and increase wear on the mud pump, drill string, and bit. Regrinding of the cuttings also tends to decrease the rate of drilling progress. A thicker filter cake will be formed on

the walls of the borehole as a result of the higher concentration of solids. As a result of the greater hydrostatic pressure caused by the higher concentration of solids, hydraulic fracturing of the formation is more likely to occur. Lastly, a denser fluid has greater buoyancy; therefore, the cuttings are less likely to settle out in the mud pit.

The density of the drilling mud should be routinely determined. Although there are situations when dense drilling fluids are desirable, measures should be taken when the density becomes too high. The density of a bentonite mud can be decreased by adding water or increased by adding a finely ground, high specific gravity additive such as barite (barium sulfate). Polymer muds are not capable of suspending a weighting agent because they have little or no gel strength. However, since many polymers are compatible with salt solutions, polymer muds with densities of over 1,380 kg/m³ (11.5 lb/gal) can be made by mixing the polymer with a saturated calcium chloride solution.

c. Gel strength. The measure of the capability of a drilling fluid to hold particles in suspension after flow ceases is referred to as gel strength (thixotropy). Gel strength results from the electrical charges on the individual clay platelets. The positively charged edges of a platelet are attracted to the negatively charged flat surfaces of adjacent platelets. In a bentonite mud in which the particles are completely dispersed, essentially all the bonds between particles are broken while the mud is flowing. When the mud pump is shut off and flow ceases, the attraction between clay particles causes the platelets to bond to each other. This coming together and bonding is termed flocculation. This edge to face flocculation results in an open card-house structure capable of suspending cuttings and sand and gravel particles. This property also suspends finely ground, high specific gravity material such as barite ($G_s = 4.23$) when high-density drilling muds are required. The capability of keeping cuttings in suspension prevents sandlocking (sticking) the tools in the borehole while drill rods are added to the string and minimizes sediment collecting in the bottom of the hole after reaming and before going back in the hole with a sampler. A drawback to this property is that cuttings do not readily settle out of the drilling mud in the mud pit and may be recirculated, thus resulting in grinding of particles by the drill bit, increased mud density, increased mud pump wear, and lower penetration rate. Polymer drilling fluids have essentially no gel strength.

d. Filtration. Filtration refers to the ability of the drilling fluid to limit fluid loss to the formation by deposition of mud solids on the walls of the hole. During drilling operations, the drilling fluid tends to move from the borehole into the formation as a result of hydrostatic pressure which is greater in the hole than in the formation. As the flow of drilling fluid (water) occurs, the drilling fluid solids are deposited on the walls of the borehole and thereby significantly reduce additional fluid loss. The solids deposit is referred to as a filter cake. The ideal filter cake is thin with minimal intrusion into the formation. The thickness of the filter cake for a particular mud is generally a function of the permeability of the formation. For example, the filter cake in a clay interval of the borehole would be thinner than in a sand interval.

Clean, well-conditioned bentonite drilling mud will deposit a thin filter cake with low permeability. Natural clay muds which result from drilling with clear water have much less desirable filtration properties than does high-grade sodium montmorillonite (bentonite). The natural clay mud will deposit a much thicker (can be more than 30 times thicker) filter cake than that of bentonite mud. A thick filter cake has a number of disadvantages which include the possibility that the cake may be eroded by circulating drilling fluid, may cause the drill pipe to stick, or may cause reduced hydrostatic pressure and partial collapse of the walls of the borehole during tool removal. The reentry of drilling equipment into the borehole lined with a thick filter cake could result in a pressure surge with an accompanying increased potential for hydrofracture of the formation. Polymer muds are low solids muds and do not form a filter cake as such. However, polymers tend to reduce fluid loss because they have a high affinity

for water and form swollen gels which tend to plug the formation pores in the borehole wall. The data presented in Table 4-3 may be useful in correcting the problem of lost circulation.

4-4. Mixing and Handling

Water quality, method of mixing, and mud pit design are important to the effective use of water-based drilling muds. Water for bentonite muds should have a pH of 7 to 9.5, but should not have calcium hardness in excess of 100 parts per million (ppm); the chloride content should be less than 500 ppm. Polymer muds may work in either fresh or salty water, although some polymer additives do not work well in water with high pH or that contains more than 3-ppm iron. Manufacturers' literature should be checked for water quality recommendations when drilling mud additives are selected.

Effective dispersion and hydration of the drilling mud solids is dependent on proper mixing. Sprinkling or pouring the dry additives into the water and relying on the drill rig pump to mix will result in a lumpy mud with excessive additives for the mud properties achieved. A simple, yet effective, mud mixer can be fabricated as illustrated in the schematic diagram in Figure 4-3. Figure 4-4 is a photograph of jet mixer for introducing solids such as bentonite into the drilling mud. High-shear mechanical mixers will also effectively mix the mud materials.

Cuttings which are transported from the drill bit to the surface by the drilling mud must be dropped prior to recirculation to minimize regrinding. Although the viscosity and density of the mud control these characteristics, the properties of the mud can be enhanced by careful design of the mud pit in which cuttings are deposited. The mud pit may be either a dug pit or a fabricated portable mud pit; the latter is recommended in most cases. In either case, the pit should be designed to allow adequate time for the cuttings to settle out of the mud before it is recirculated. Considerations in the design of the mud pit should include: (a) the mud should flow slowly in thin sheets; (b) it should change directions frequently; and (c) it should flow as far as possible. To accomplish these considerations, the design of the mud pit should be shallow with a large rectangular surface area. Baffles can be used to force the mud to change directions frequently. The volume of the mud pit should be approximately three times larger than the volume of the hole to be drilled. A schematic diagram and a photograph of a portable mud pit are given in Figures 4-5 and 4-6, respectively.

Excessive cuttings are seldom a problem when core drilling but are common when drilling without sampling in sands and gravels. In some cases, it may be very difficult to obtain acceptable rates of settlement of the cuttings in the mud pit. Consequently, the cuttings may be recirculated and reground during recirculation. Desanding cones are available which effectively remove extraneous solids that do not settle out in the mud pit. Figure 4-7 shows a small desanding cone.

4-5. Drilling and Sampling Problems

During conventional drilling and sampling operations, unanticipated problems may be encountered. For example, an unstable formation or a zone of lost circulation may be encountered, or samples may be extremely difficult to recover or of very poor quality. The technology presented in Table 4-3, when used in conjunction with data presented in Tables 4-1 and 4-2, can be used to design a high-quality drilling fluid which can be applied for a wide range of drilling and sampling conditions encountered during geotechnical investigations. For most cases, a properly designed drilling fluid can minimize adverse drilling and sampling problems while simultaneously enhancing the capabilities of and extending the life of the drilling and sampling equipment. Selected topics are discussed in the following paragraphs.

a. *Hole stabilization.*

(1) *Caving.* Caving is often associated with uncemented sands and gravels, especially when removing samples from the hole. The problem can usually be remedied by maintaining excess hydrostatic pressure in the borehole. During drilling, circulating water is often adequate to maintain hole stability. However, when the pump is shut off, the water level in the borehole tends to drop to the water level in the formation. In order to maintain a fluid level in the hole above the groundwater level, a filter cake is required for filtration control of the drilling mud. Either bentonite or bentonite/polymer mud can be used to build a filter cake that effectively controls caving. The viscosity of the mud should be as low as practical to provide a stable hole. Polymer muds can sometimes be used for this purpose, although the cost of a polymer mud is generally greater than the cost of a bentonite mud of similar viscosity.

If samples are taken in a mud stabilized hole in sand or gravel, the sampler should be withdrawn slowly from the hole to avoid creating negative hydrostatic pressure below the sampler. Care is also necessary to ensure that the mud level in the borehole is maintained above the static water level as the sampler and rods are withdrawn. A suggested method to help maintain a constant fluid level in the borehole and to reduce the negative hydrostatic pressure below the sampler is to operate the mud pump at a low pressure and flowrate as the rods are withdrawn. An alternative method is to pump mud from the pit to the top of the hole through the bypass hose. Fractured clays may also cause a hole to cave which can generally be controlled in the same manner as for caving sands or gravels.

(2) *Squeezing ground.* Squeezing ground can result from either high lateral stresses acting on weak soils or expansive clays or shales imbibing water from the drilling fluid and swelling into the borehole. In most cases, squeezing and hole deformation occur soon after encountering the particular formation. The importance of maintaining stable hole conditions cannot be overemphasized. Once the stable cylindrical shape is lost, hole stability becomes a greater problem.

A good example of when it may be necessary to exceed the recommended maximum mud density of 1,080 kg/m³ (9.0 lb/gal) is to counteract the high lateral stresses which often exist in foundation clays very near or beneath large embankments. The use of bentonite mud weighted with barite can be very effective in preventing squeezing due to the lateral stresses. However, weighted drilling mud should not be used for drilling through the embankment, as the embankment material could be hydrofractured by the hydrostatic pressure of the drilling fluid.

Because of the potential for hydraulic fracturing, it is desirable to drill an embankment without drilling fluid. One method is the use of augers. However, if it is not possible to conduct the drilling without a drilling fluid, clear water or water-based mud may be the only suitable solution to the problem but should be used only with extreme caution. The viscosity, density, and gel strength of the mud should be kept to a minimum. Drilling tools should be raised and lowered very gently. The fluid pump should be engaged slowly. The recirculation of solids in the drilling fluid should be carefully monitored and minimized.

After the hole has been drilled through the embankment, casing should be set through the embankment and seated in the foundation material. The water or low density mud which had been used to drill the embankment can then be removed from the borehole and replaced with bentonite mud weighted with barite before the potentially squeezing foundation soils are drilled.

Swelling clays and shales can be stabilized by polymer muds. Polymer muds form a protective coating on the water sensitive materials which inhibits swelling of either the borehole wall or cores in the sample barrel. Polymer muds also inhibit the dispersion of the clayey cuttings into the drilling mud which tends

to make the clay cuttings less sticky and less likely to adhere to each other. Hence, the potential for hydrofracturing is reduced.

b. Control of hydrostatic pressure. It is sometimes necessary to drill formations where the piezometric surface is above the ground surface. If this situation occurs, such as near the downstream toe of a dam, advanced planning is required to ensure that the flow of water in the borehole is controlled.

Suggested methods for controlling excess hydrostatic pressures in boreholes include the use of casing filled with water or drilling mud, the use of weighted drilling mud, and the use of a wellpoint system. If the piezometric surface is less than approximately 0.3 to 0.6 m (1 to 2 ft) above the ground surface, a section of casing may be extended above the ground surface and filled with water or drilling mud prior to commencing the drilling operations. This height of the casing was selected as representative of the clearance between the bottom of the drill rig and the ground surface. When the proper head of water is maintained in the casing, the flow of fluid into or out of the borehole can be minimized.

If the piezometric surface is greater than about 0.6 m (2 ft) above the ground surface, a wellpoint system or the use of weighted drilling mud may be required. The increase of mud density which is needed to balance the formation pressures can be achieved by adding barite to a bentonite mud or by using a polymer mud in a calcium chloride solution. When weighted drilling muds are used, care should be exercised to ensure that hydrofracturing of the subsurface formation does not occur. A discussion of the design and installation of a wellpoint system to control excess hydrostatic pressures is not within the context of this manual.

The following example is cited for estimating the required mud density (weighted mud) to balance the hydrostatic pressure in the aquifer:

Problem:

A 6 m (20 ft) layer of clay overlies an aquifer in sandy soil. The piezometric surface of the aquifer is 2-1/2 m (8 ft) above ground surface. What is the density of the drilling mud required to balance the hydrostatic pressure in the aquifer?

Solution:

The critical fluid pressure (P_c) which must be balanced during drilling is the pressure at the top of the sand (6 m of clay plus 2-1/2 m hydrostatic head above the clay strata). The unit weight of water (γ_w) is 1,000 kg/m³ (8.34 lb/gal). The fluid pressure of a column of water (P_w) is 9.8 kPa/m (0.43 psi/ft) of height.

$$\begin{aligned} P_c &= \text{height of piezometric surface above ground surface} * P_w \\ &= 8\text{-}1/2 \text{ m} * 9.8 \text{ kPa/m} \end{aligned}$$

$$\begin{aligned} P_c &= 83 \text{ kPa} \\ &= 12 \text{ psi} \end{aligned}$$

The mud density (γ_m) required to balance P_c at the sand and clay interface can then be calculated.

$$\begin{aligned} \gamma_m &= (P_c * \gamma_w) / (P_w * \text{depth to sand}) \\ &= (83 \text{ kPa} * 1,000 \text{ kg/m}^3) / (9.8 \text{ kPa/m} * 6 \text{ m}) \end{aligned}$$

$$\begin{aligned}\gamma_m &= 1,410 \text{ kg/m}^3 \\ &= 11.7 \text{ lb/gal}\end{aligned}$$

Discussion:

It should be noted for the example that the factor of safety with respect to flow of water is 1.0. This condition is most desirable. If the mud density is too low, groundwater will tend to flow into the borehole and increase the potential for piping of formation materials. If the mud density is too high, the potential for hydrofracturing of the formation is increased.

To maintain a factor of safety of 1.0, the following guidance is offered. Make an estimate of the required density of the drilling mud to balance the excess hydrostatic pressure, as illustrated in the example. During drilling operations, frequent observations of the flow of water (or drilling mud) into or out of the borehole should be made. If groundwater tends to flow into the borehole, the density of the drilling mud should be increased slightly. If there is no tendency for seepage of groundwater into the borehole, the weight of the drilling mud may be excessive and should be decreased slightly until an equilibrium condition is obtained. This condition can be accomplished by adding clear water to the drilling mud until the groundwater tends to slowly seep into the borehole. It is imperative that an equilibrium condition for the hydrostatic pressures is maintained to ensure stability of the foundation conditions.

c. Improved sample recovery.

(1) *Soil sampling.* The overall quality of the soil samples is generally better when a bentonite based drilling mud, as compared to other drilling fluids, is used. Several explanations are available. The use of mud with a fixed-piston sampler results in a more effective seal at the piston with less chance of sample loss. Furthermore, bentonite mud forms a filter cake (membrane) on the bottom of the sample; the hydrostatic forces act on this membrane in the same manner as on the walls of the borehole to hold the sample in the sampling tube. The ability to maintain the drilling fluid level at or near the top of the hole increases the possibility of a full sample recovery because of buoyancy effects; the buoyancy effects are very important, especially when sampling sands below the water table. Fluid pressure can be controlled to prevent both squeezing and sand heaving. Heaving is particularly undesirable in liquefaction studies where small changes in density and stress relief are very important.

Bentonite or bentonite/polymer muds are usually suitable for most soil sampling applications. Weighted bentonite mud may be required to reduce hole squeezing or to balance high hydrostatic pressures. Mud migration into tube samples or into the virgin material in the bottom of the borehole has been observed to be minimal. However, the comparison of gradations from SPT samples and fixed-piston thin-walled tube samples of sands suggests mud contamination of the SPT samples as evidenced by a higher percentage of fines.

(2) *Rock coring.* Core recovery and overall sample quality can be improved in some situations. In most cases, clear water is the most desirable and cost-effective drilling fluid for rock core drilling. However, drilling muds, especially polymer muds, have specific applications, e.g., polymer muds can be effective in reducing the swelling of clay shales. In some instances, swelling shales are effectively cored with apparently good recovery; however, due to their swelling in the core barrel they are essentially destroyed when the swollen core is removed from the barrel.

Polymer muds have also been effective in improving core recovery and reducing mechanical core breakage during drilling of generally competent rock containing weaker shale partings, bands, and thin beds. The overall strength of the rock mass is generally controlled by the geometry and strength of the much weaker shale seams. In too many cases, these weak zones are represented by a core loss. Sheared

surfaces often exist in the weak zones and are also lost during drilling. Because of the superior lubricating qualities of polymer muds, their low solids content, and nonwetting properties, they offer improved recovery of the critical shale zones which eliminates worst case strength assumptions. In addition, the uphole velocity of the drilling fluid can be reduced because of the increased viscosity of the mud; the effect is to reduce the probability of washing away weak bedrock materials.

The three factors following must be considered if a drilling mud is to be used: the effects of a “slick” polymer mud on laboratory test results, especially if the sample contains open fractures or bedding planes which must be tested, the impact on borehole hydraulic pressure test results if mud migrates into the fractures, and the ease with which the mud releases the cuttings in the surface settling pit especially if the cuttings are fine, as from diamond drilling operations.

d. Enhanced pump capacity. Because excessive pump capacity has a negative impact on core recovery, many drill rigs used for geotechnical investigations have pumps which are ideal for core drilling but are somewhat undersized for nonsampling drilling, such as for cleaning the borehole between soil samples or for installation of piezometers or wells or various types of instrumentation. To overcome this problem, proper design of the drilling mud and the effective use of the drilling equipment must be considered. Recall that hole cleaning is controlled by the uphole velocity of the drilling fluid as well as its viscosity and density. As given by Equation 4-1, the uphole velocity is dictated by the pump capacity and the area of the annulus between the drilling tools and the walls of the borehole. For most cases, the diameter of the hole is predetermined by sampling or instrumentation requirements. However, the viscosity and density of the drilling fluid can be enhanced by additives. In most situations, it is better to increase viscosity while keeping mud density as low as possible. Bentonite or bentonite/polymer muds are usually the most effective means of making a drilling mud of the required viscosity. If a very high viscosity is needed, a polymer mud might be most effective since it is a low solids mud and has a very low gel strength which would allow better removal of the cuttings. The use of weighted mud can be advantageous when large cuttings or gravel must be removed from the hole.

e. Solids recirculation. Recirculation of excessive solids results in increased density of the drilling mud. The adverse effects include a reduced rate of drilling with an increased potential for hydraulic fracturing, an increase of the thickness of the filter cake which is more easily eroded and contributes to a less stable hole as compared to a thin filter cake, and excessive abrasive solids in the drilling mud which cause significant wear to the mud pump and the drilling tools. In most cases, a well-designed portable mud pit and a carefully selected low solids mud with an appropriate gel strength coupled with regular mud density measurements will control the problem. However, desanders may be needed when drilling large-diameter or deep holes in sands and gravels.

The addition of polymer additives to the drilling fluid also acts to reduce wear on drill rods, core barrels, and pumps. The benefits are most noticeable when drilling abrasive rock types such as sandstones and rock containing chert. In addition to the reduced wear, the drilling operations are often smoother with less rod “chatter” resulting in less broken core. Although the concentration of polymer additives for this purpose is relatively low, the potential impact on hydraulic pressure test results must be considered. Experience as well as the manufacturer's recommendations should dictate the choice and concentration of the additives.

4-6. Limitations and Precautions

As with all other aspects of planning and executing a quality drilling and sampling program, all facets of the selected drilling fluid should be understood and considered. A discussion of limitations and precautions for the use of drilling fluids for selected drilling and sampling operations follows.

a. Hydraulic fracturing. Hydraulic fracturing of earth dam embankments is a concern whenever a drilling fluid is used in the fill. The potential for hydraulic fracturing has been directly attributed to the use of compressed air as the drilling fluid; hence, the use of compressed air for drilling in earth dams is prohibited by ER 1110-2-1807. Likewise, the potential for hydraulic fracturing to occur whenever water or water-based drilling mud are used also exists. However, it is easier to control the drilling fluid pressures when using water or mud than when using compressed air. Therefore, the risk of hydraulic fracturing is minimized. For these reasons, dry drilling methods which do not use a circulating fluid, such as dry hole augering, may offer an ideal solution for specific problems of drilling in embankment dams. Unfortunately, dry drilling methods are not always practical or even possible for many cases.

Several factors should be considered when water or water-based drilling mud are used for drilling in embankment dams. The sensitivity of an embankment to fracturing is dependent upon the strength properties, the tightness of lift planes, and the stress distribution in the compacted embankment. Hydraulic fracturing is most critical in and perhaps most likely to occur in the impervious core. The pressure which is needed to extend a fracture may be less than the pressure required to initiate the fracture. Hydraulic fracturing is more likely to occur when using core barrel sampling devices, e.g., the Denison or Pitcher sampler, because drilling fluid must flow at high pressures through the small annular space between the sampler and borehole wall. Poorly maintained piston-type mud pumps exhibit pressure surges which can easily fracture the embankment.

If the wet drilling method is required, the equipment is in good working order, and the samplers have been carefully selected, several precautions should be observed. The viscosity and density of the drilling mud should be kept at the minimum required to clean and stabilize the hole. The viscosity and density should be checked frequently during drilling operations. Polymer or bentonite/polymer muds may be used to keep the gel strength low. The drilling tools should be raised and lowered in the hole slowly and smoothly. Rotating the tools as they are raised and lowered may also be helpful. The pump should be engaged slowly to begin circulation. Due to the recirculation of cuttings, the mud weight will tend to increase with drilling time. Until an experience base has been developed, use a maximum allowable density of 1,080 kg/m³ (9.0 lb/gal). If this density is exceeded, replace the used mud with freshly mixed mud. Select drilling methods which minimize the formation of a mud collar which tends to create zones of high pressure in the drilling fluid below the obstructions. Fishtail bits cut long ribbons which tend to form obstructions. Long-toothed roller bits rotated at fairly high angular velocities with little downward pressure create kernel-like, easily transported cuttings. Polymers reduce the tendency of clays to become sticky.

b. Formation permeability. If a mudded borehole is ultimately to be used for the installation of a water well, piezometer, pore pressure device, or monitoring well or if it is to be pressure tested, one must assume that a filter cake was formed and that it has invaded the pore space of granular materials, the fractures of bedrock, or even clays to some unknown distance. To have an efficient water well or observation device or to avoid erroneous chemical analyses from monitoring wells, it is important that the filter cake be broken down and removed and the permeability of the drilling mud invaded portion of the formation be restored. Restoration of the formation requires careful attention to and the evaluation of development techniques. Often, an effective first step is to flush mud from the hole and replace it with clear water after setting the pipe and screen but before adding the filter pack. An alternative procedure

consists of drilling with mud to a point just above the tip, filter, and seal interval. Casing is then set to the bottom of the mud-filled hole and carefully sealed. The mud is either bailed from the casing or flushed out and replaced with clear water. The hole is then drilled with clear water to the final depth, the device set, and the filter and seal placed. The remainder of the backfill is placed concurrent with pulling the casing. A degradable natural polymer made from the Guar bean has also been used for drilling wells and piezometers. Although the polymer reportedly degrades naturally because of the action of enzymes and returns to the viscosity of water within a few days, the effects of the degradation of this product on the chemical analysis of water should be considered.

c. Environmental drilling. It is preferable to drill monitoring wells for the investigation of hazardous and toxic waste sites with dry drilling methods, such as the hollow-stem auger or churn drill methods. However, in many cases mud rotary drilling is the most effective and practical method. When mud is used for environmental drilling, certain precautions should be observed and practiced. Very complete and careful development of monitoring wells is mandatory both to restore aquifer permeability and to remove as much of the drilling mud as possible in order to minimize potential impact of the drilling fluid additives on the groundwater chemistry. A chemical analysis of drilling muds and additives should be performed (and obtained from the supplier). All organic polymer muds should be avoided. Products identified as “beneficial bentonites” contain organic additives which enhance viscosity and should not be used for this purpose. Standard bentonite, which is commonly used for monitoring well drilling, also contains minor amounts of additives and perhaps should be avoided. Pure bentonite muds are available and are marketed specifically for monitoring well construction. Although pure bentonite has apparent chemical advantages, it will not mix and hydrate as quickly and easily as standard or beneficiated bentonites.

d. Effect on strength testing. Samples for strength testing should be carefully inspected for drilling mud infiltration, especially into open fractures and bedding planes. Either bentonite or polymer mud could tend to alter the apparent shear strength along these discontinuities.

4-7. Good Drilling Practices

Careful drilling practices used in conjunction with a drilling fluid which is most suitable for the purpose(s) of the geotechnical investigation will optimize drilling progress and sample quality while minimizing sample disturbance. To effectively apply this technology, a number of factors must be considered and practiced. Know the purpose of the drilling or sampling program, the geology of the area, and the drilling equipment and its capability. Become familiar with drilling fluid additives and the effects of each on drilling operations. Keep field operations as simple as possible to effectively complete the job; a well designed portable mud pit, Marsh funnel, and mud balance are satisfactory for most situations. Maintaining a low mud density minimizes viscosity, reduces pressure within the borehole annulus caused by the circulating fluid, and minimizes the filter cake thickness. Start the mud pump slowly to avoid excessive pump pressures due to the gel (thixotropic) strength of the mud. Operate pump pressures as low as possible to minimize surge pressures. Raise and lower the drill string slowly to minimize hydrostatic pressure changes. Drill formations no faster than solids are removed from the drill bit. Anticipate problems before they develop; take precautions to reduce the effects of the potential problems.

Table 4-1
Properties of Drilling Mud (after N.L. Baroid / N.L. Industries, Inc.)

| Property | Influences | Desirable Limit | Control |
|-------------------------------------------------|----------------------------------------------------------------------------------|------------------------------------------------------------------------------------|------------------------------------------------------------------------------------|
| Density
(Weight) | Drilling rate
Hole stability | Less than about
1,080 kg/m ³
(9.0 lb/gal)
(mud balance) | Dilute with water or remove solids to decrease
Add barium to increase |
| Viscosity | Cuttings transport
Cuttings settlement
Circulation pressures | 34-40 sec/dm ³
(32-38 sec/qt)
(Marsh funnel and
measuring cup) | Add water, phosphates, or lignites to thin
Add bentonite or polymers to thicken |
| Filtration | Wall cake thickness | Very thin (less than
0.2 cm {1/16 in.}) | Control density and viscosity of mud
Polymers |
| Sand content | Mud density
Abrasion to equipment
Drilling rate | Less than 2 percent
by volume | Add water to lower viscosity
Good mud pit design
Use desander |
| pH
(Acidity or
alkalinity) | Mud properties
Filtration control
Hole stability
Corrosion of equipment | 8.5 to 9.5
(Neutral is 7.0) | Increase with sodium carbonate
Decrease with sodium bicarbonate |
| Calcium
content ¹
(Hard water) | Mud properties
Filtration control | Less than 100 parts
per million (ppm)
calcium | Pretreat mixing water with sodium bicarbonate |

¹ For other salts, dilute salt content with fresh water or use organic polymers in the drilling fluid.

EM 1110-1-1804
1 Jan 01

Table 4-2
Control of Drilling Mud Properties (after N. L. Barold / N. L. Industries, Inc.)

| Description | Velocity | Filtration | Lost Circulation | pH | Wetting Agent | Calcium Remover | Shale/Clay Control | Weight Material |
|---------------------------------------------|-----------------|-------------------|-------------------------|-----------|----------------------|------------------------|---------------------------|------------------------|
| Sodium Montmorillonite (Standard bentonite) | X | X | | | | | | |
| Polymer muds | X | X | | | | | X | |
| Flake mica | | | X | | | | | |
| Shredded organic fiber | | | X | | | | | |
| Crushed nut hulls | | | X | | | | | |
| Ground paper/ cellophane film | | | X | | | | | |
| Sodium bicarbonate/ soda ash | | | | X | | X | | |
| Sodium hydroxide/ caustic soda | | | | X | | X | | |
| Water soluble detergent | | | | | X | | | |
| Barium sulfate | | | | | | | | X |

Table 4-3
Borehole Problems (after N. L. Baroid / N. L. Industries, Inc.)

| Problems | Symptoms | Necessary Conditions | Treatment | Minimize Potential Problems |
|---------------------------------------|-------------------------------------------------------------------------------------------------------------------------------------------|---------------------------------------------------------------------------------------------------------------------------------------------------------------------------|----------------------------------------------------------------------------------------------------------------------------------------------------------------------------------------------------------------------------------------------------------------------------------|--------------------------------------------------------------------------------------------------------------------------------------------------|
| Stuck pipe
(differential sticking) | Good circulation at normal pressures
Cannot rotate drill rods
Cannot pull drill string
Bit may not be the bottom of the borehole | Permeable zone
Thick mud cake on wall of hole
Hydrostatic pressure of drilling fluid exceeds hydrostatic pressure in formation | Work drill pipe
Reduce mud density
Add surfactant / lubricant | Minimize fluid density and solids content
Minimize filtration rate with thin filter cake
Lower friction between filter cake and drill rods |
| Loss of circulation | More fluid is being pumped into hole than is being returned
Level of fluid in mud pit drops | Normal fractures
Induced fractures
Highly permeable formations
Cavernous formations | Stop drilling and allow mud to seep into fractures (self-healing)
Raise drill string above loss zone and introduce lost circulation materials
Seal must be in loss zone and not on face of boring
Treat gently after sealing
May be necessary to use casing or grout | Examine fluid properties (density, viscosity, and filtration) frequently
Observe careful drilling practices |
| Unstable hole | Hole enlargement
Tight hole
Fill on bottom of borehole after trip to surface | Structural instability of weak formations due to rotation and vibration of drill rods, pressure surge or swab, or excessive pump pressures
Wetting of clays and shales | Lower pump pressures
Add friction reducers and/or polymers to drilling mud | Examine fluid properties frequently
Observe careful drilling practices |

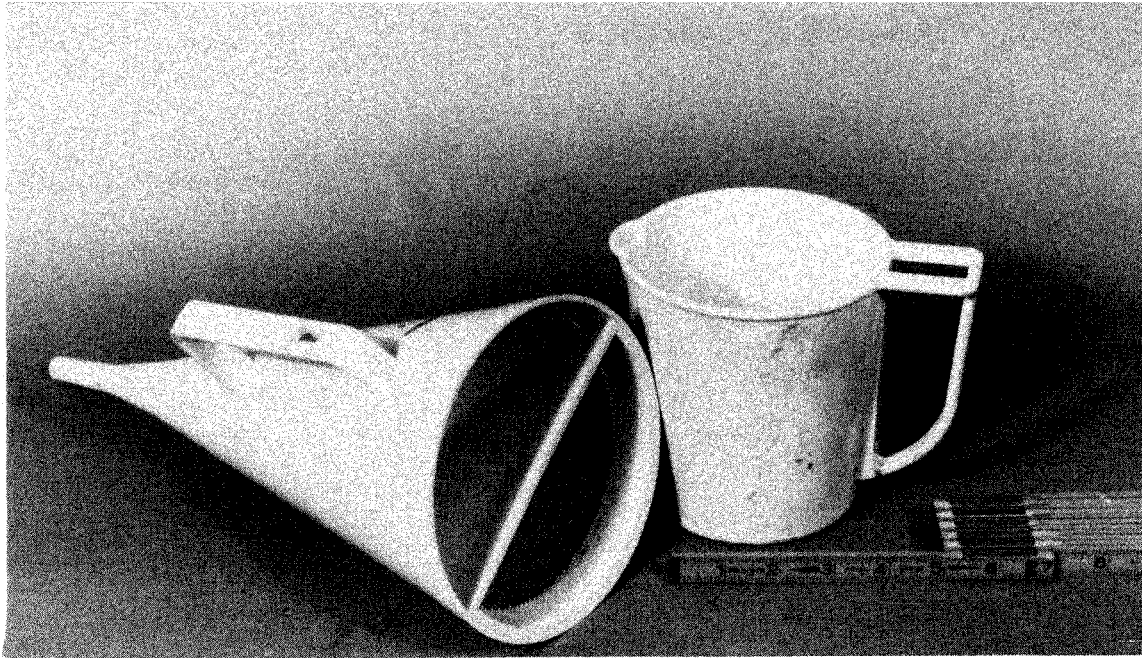

Figure 4-1. Photograph of a Marsh funnel and a one quart (0.95 dm³) measuring cup for determining the viscosity of drilling mud

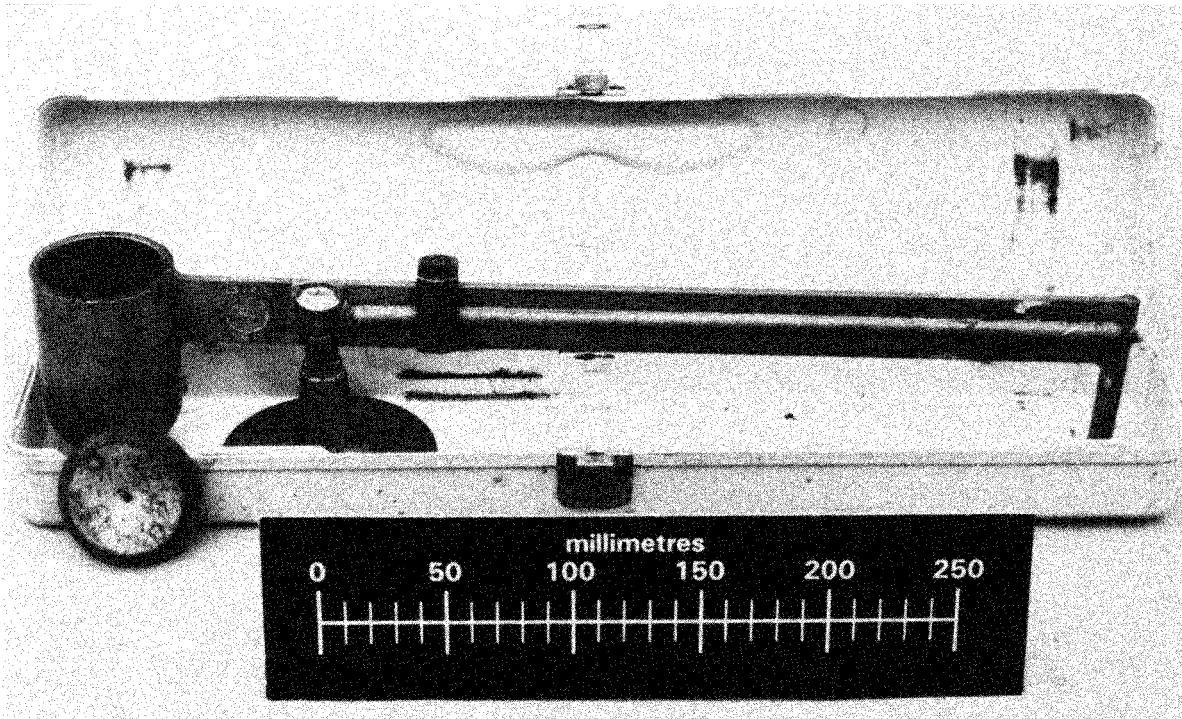

Figure 4-2. Mud balance for determining the density of drilling mud

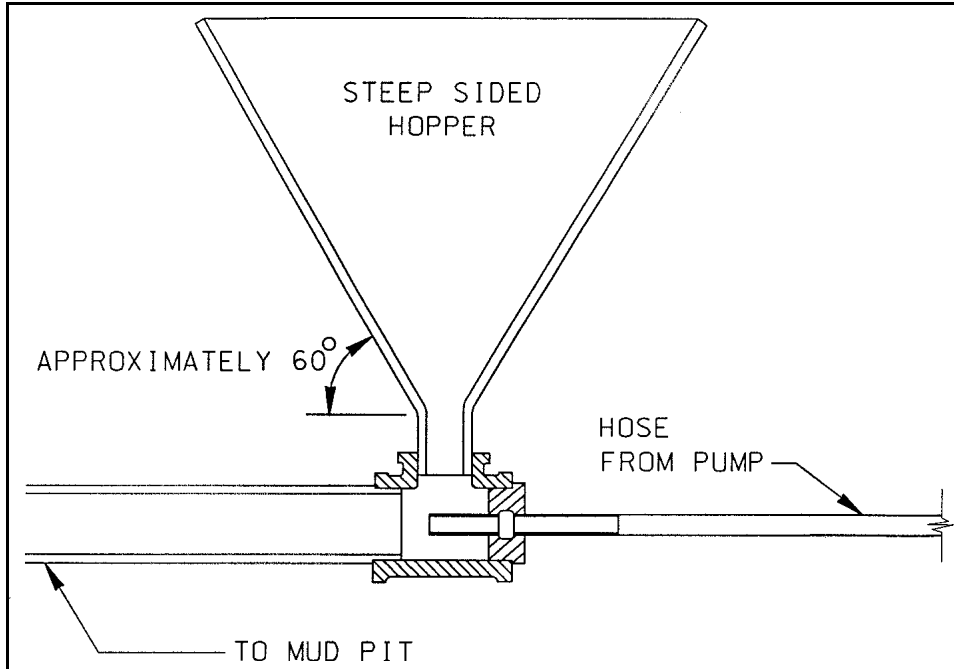

Figure 4-3. Schematic of a steep sided hopper mud mixer

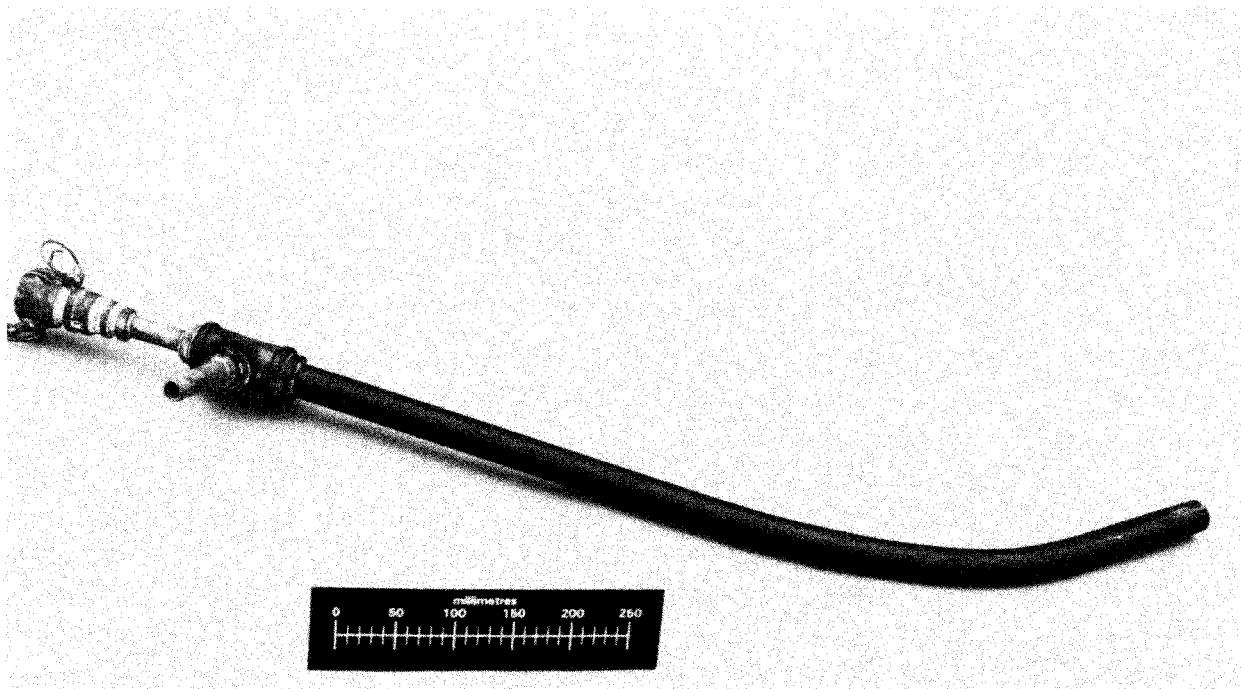

Figure 4-4. Photograph of a jet mud mixer

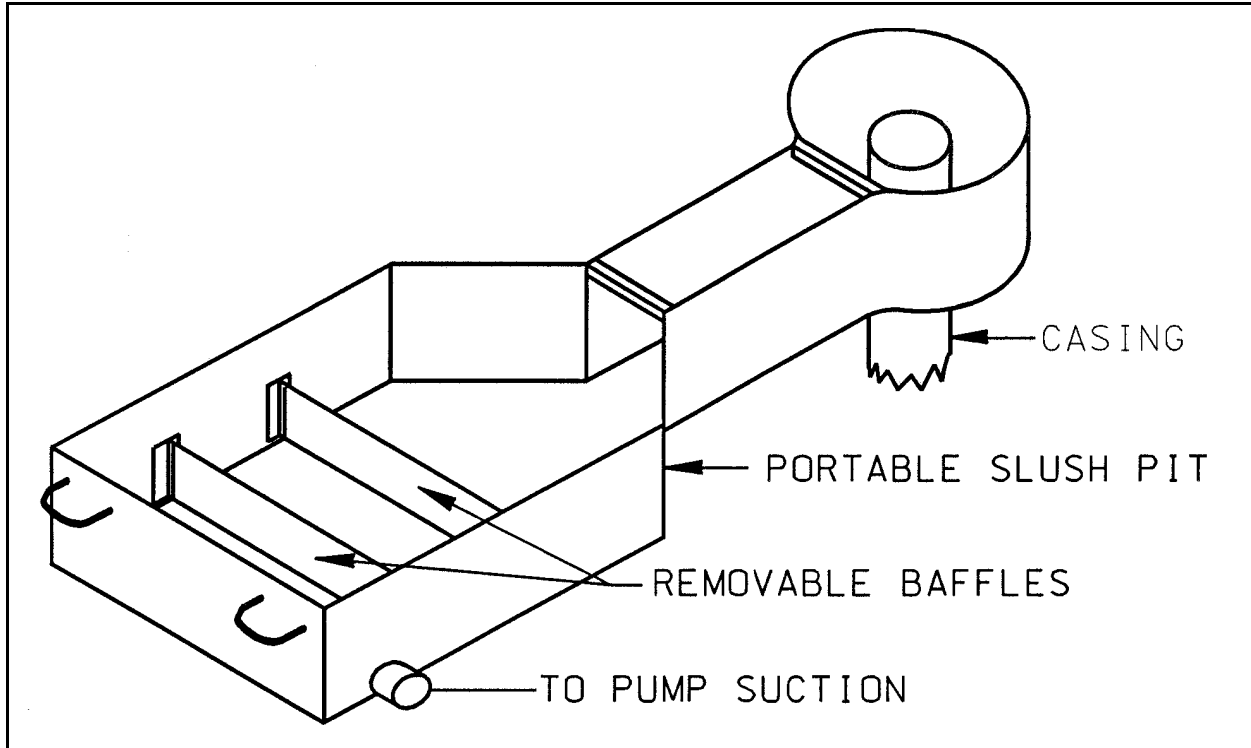

Figure 4-5. Sketch of a portable mud pit

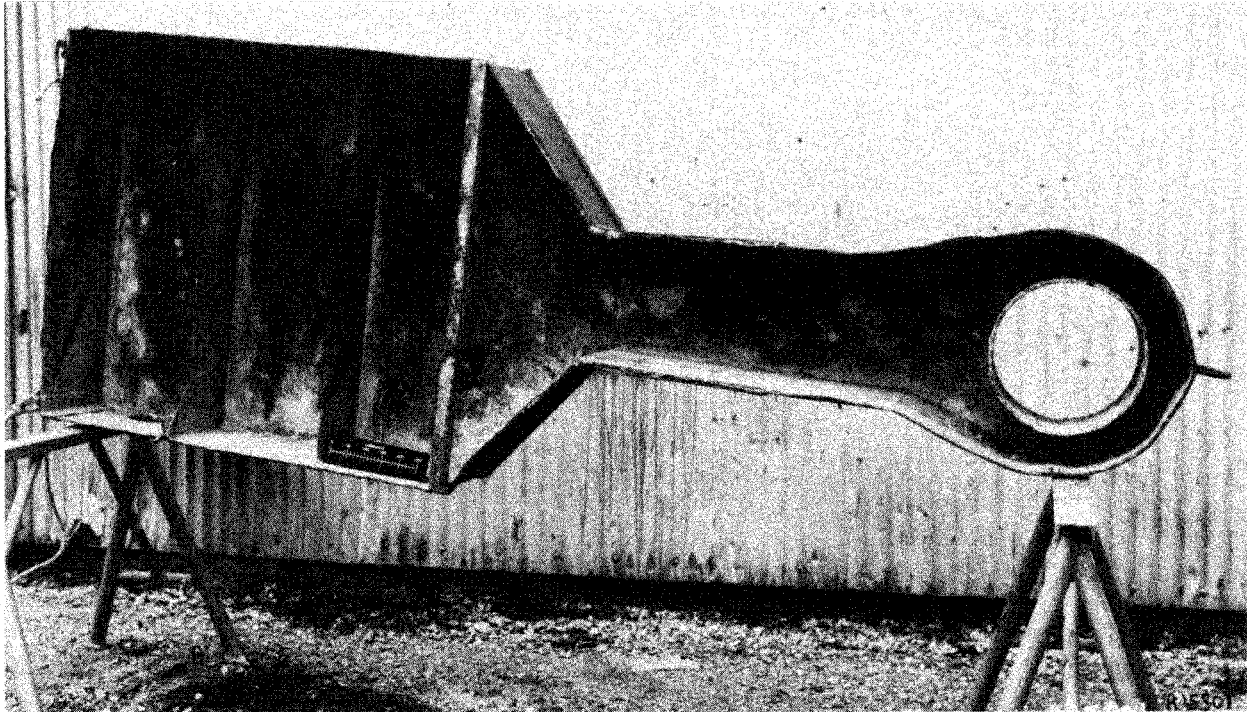

Figure 4-6. Photograph of a portable mud pit

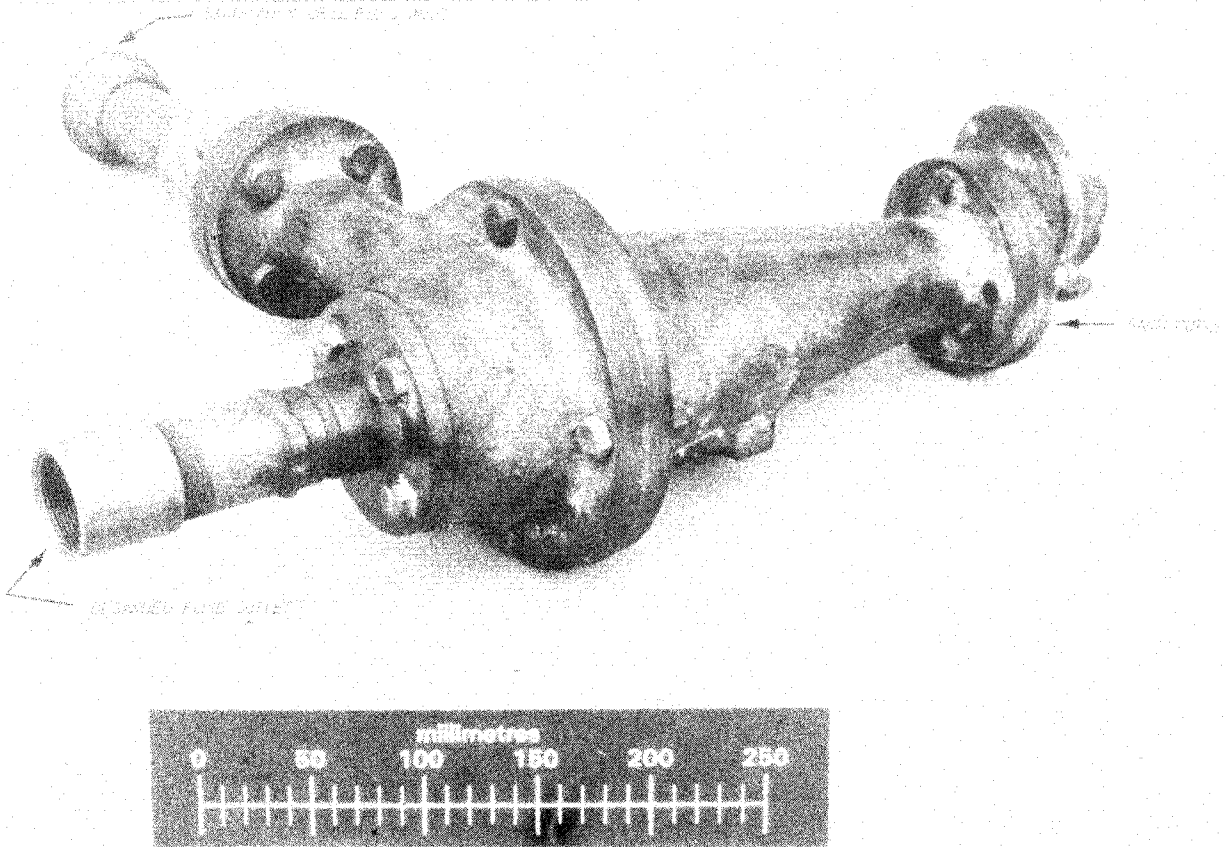

Figure 4-7. Photograph of a small desanding cone

Chapter F-5 Equipment for Undisturbed Soil Sampling in Borings

5-1. Sampler Types

A variety of samplers are available for obtaining undisturbed soil samples. Basically all are variations of the push-type thin-walled tube samplers or rotary core barrel samplers. Push-type tube samplers may be used to obtain samples of soft-to-medium clays and fine sands. These samplers should not be driven by hammering to obtain undisturbed samples. A rotary core-barrel type sampler should be used to obtain undisturbed samples of soils too hard to permit smooth penetration of the push-type sampling tube or soils which contain gravel that may damage the tube as well as disturb the soil sample. Procedures for undisturbed soil sampling in boreholes are discussed in Chapter 6.

a. Push-tube samplers. Push-tube samplers are merely pushed into the undisturbed soil in one continuous, uniform motion without rotation. These samplers may be used for obtaining undisturbed samples of most soils which are not too hard to penetrate or contain gravels. When a properly beveled cutting edge on the sampling tube is used, the soil which is displaced by the sampling tube is compacted or compressed into the surrounding soils.

Push-tube samplers can be subdivided into two broad groups: open samplers and piston samplers. Open samplers consist of an open tube which is attached to a vented sampler head. The open tube admits soil as soon as the tube is pushed into the soil. The sampler head may be equipped with a ball check valve which holds a partial vacuum above the sample that aids in sample recovery and prevents the entrance of drilling fluid during sample withdrawal. Piston samplers have a movable piston located within the sampler tube. The piston keeps drilling fluid and soil cuttings out of the sampling tube as the sampler is lowered into the borehole. It also helps to retain the sample in the sampling tube by holding a partial vacuum above the sample that aids in sample recovery.

As compared to piston samplers, open samplers are cheap, rugged, and simple to operate. The principal disadvantages include the potential for obtaining nonrepresentative or disturbed samples due to improper cleaning of the borehole or collapse of the sides of the borehole and loss of the sample during recovery.

(1) *Open samplers.* The sampling tubes for open samplers may be either thick-walled or thin-walled. However, thick-walled tubes generally exceed the area ratio of 10 to 20 percent which is specified in paragraph 2-3a. Therefore, the quality of undisturbed samples which are obtained with the thick-walled sampling tubes is suspect. Hence, only thin-walled samplers are discussed in this section.

The thin-walled open sampler consists of some type of seamless steel tube which is affixed to a sampler head assembly with screws as suggested by ASTM D 1587-83 (ASTM 1993). The sampler head assembly is equipped with vents which permit the escape of air or drilling fluid from the tube as the sampler is advanced. The vents should be equipped with a ball check valve to prevent entrance of drilling fluid during withdrawal and to create a partial vacuum above the sample which aids in sample recovery. Sampler heads for 7.5- or 12.5-cm- (3- or 5-in.-) diam tubes are available. The sampler head assembly for the 7.5-cm-(3-in.-) diam tubes can also be modified to fit the 12.5-cm- (5-in.-) diam tubes by use of an adapter ring.

The sampling tubes may be cold-drawn seamless or welded and drawn over a mandrel steel tubing. The tubes may be of variable length but are commonly furnished in 0.91-m (36-in.) lengths. The tubes are normally 7.5- or 12.5-cm OD and are sharpened on one end. Because the quality of the sample depends partially on the wall thickness of the tube, the tube with the thinnest wall possible will generally provide better samples. Typically, the wall thickness should be 14 gauge (0.211 cm or 0.083 in.) for the 7.5-cm-diam tubes and 11 gauge (0.305 cm or 0.120 in.) for the 12.5-cm-diam tubes. To minimize the potential for damage of the thin-walled tubes by buckling or by blunting or tearing of the cutting edge and disturbance to the sample, the sample tube is pushed into the undisturbed soil in one continuous, uniform motion without rotation.

One end of the tube should be beveled or tapered to form a sharpened cutting surface (paragraph 2-3). The taper angle on the outside surface should be about 10 to 15 deg. The ID of the cutting edge should be equal to or slightly less than the ID of the tube. This inside clearance, i.e., inside clearance ratio, is necessary to minimize the drag of the soil sample on the inside of the tube and still retain the sample in the tube. Cohesive soils and slightly expansive soils require larger inside clearance ratios, while soils with little or no cohesion require little or no inside clearance ratios. Typically, sampling tubes with inside clearance ratios, or swage, of 0 to 1.5 percent of the tube ID are commonly used. (See paragraph 2-4.)

Thin-walled open samplers can be used to obtain samples of medium soft to medium stiff cohesive soils. Materials which cannot be sampled with this device include soils which are hard, cemented, or too gravelly for sampler penetration, or soils which are so soft or wet that the sample compresses or will not stay in the tube. However, open tube samplers are not recommended for obtaining undisturbed samples from boreholes. The quality of the sample may be suspect because of the inherent design of the sampler. During sampling operations, the pressure above the sample may increase because of drilling fluid in the barrel of the sampler or overdriving of the sampler. During withdrawal, vibrations of the sampler and/or the vacuum created under the sample may result in loss of the sample. Figure 5-1 is a schematic drawing of an open sampler. A diagram of sampling operations using the open tube sampler is presented in Figure 5-2.

(2) *Piston samplers.* Pistons were incorporated into the design of samplers to prevent soil from entering the sampling tube before the sampling depth is attained and to reduce sample loss during withdrawal of the sampling tube and sample. The vacuum which is formed by the movement of the piston away from the end of the sampling tube during sampling operations tends to increase the length of the sample recovered. The advantages of piston samplers include: debris is prevented from entering the sampling tube prior to sampling; excess soil is prevented from entering the sampling tube during sampling; and sample recovery is increased. Hvorslev (1949) stated that the piston sampler “has more advantages and comes closer to fulfilling the requirements for an all-purpose sampler than any other type.” The principal disadvantages of the piston samplers are increased complexity and cost.

Three general types of piston samplers include free- or semifixed-piston samplers, fixed-piston samplers, and retractable-piston samplers. A brief synopsis of each type of piston sampler follows.

Free- or semifixed-piston samplers have an internal piston which may be clamped during withdrawal of the sampling tube. During the actual sampling operations, the piston is free to move with respect to the ground level and sample tube.

To obtain a sample with a fixed-piston sampler, the sampling apparatus is lowered to the desired level of sampling. The piston is then freed from the sampler head, although it remains fixed relative to the

ground surface. The sample is obtained, and the piston is again clamped relative to the sampler head prior to extracting the sample and sampling tube from the borehole.

The retractable-piston sampler uses the piston to prevent unwanted debris from entering the sample tube while lowering the sampler to the desired depth. Prior to the sampling operation, the piston is retracted to the top of the tube. However, this operation may cause soil to flow upward into the tube. Consequently, the retractable piston sampler is not recommended for undisturbed sampling operations and is not discussed herein.

(a) *Free- or semifixed-piston samplers.* Free- or semifixed-piston samplers have overcome many of the shortcomings of open samplers while remaining easy to use. The piston is locked at the bottom of the sampler barrel as the sampler is lowered into the borehole. At the desired sampling depth, the piston is unlocked by rotating the drill rods. During the push, the piston rests on the sample entering the tube. Before the sampling tube is withdrawn, the piston rod is locked to prevent downward movement which aids in sample recovery. Free-piston samplers may be used in stiff clays or partially saturated silts and clays.

(b) *Fixed-piston samplers.* There are two basic types of fixed-piston samplers: the mechanically activated types, which include the Hvorslev and Butters samplers, and the hydraulically activated types, such as the Osterberg and modified Osterberg samplers. The basic principle of operation of fixed-piston samplers is the same as for thin-walled push-tube samplers, i.e., to force a thin-walled cylindrical tube into undisturbed soil in one continuous push without rotation. The piston is locked in a fixed position before, during, and after the sampler advance. As the sampler is lowered into the borehole, the piston is fixed relative to the cutting edge of the sampler to prevent foreign particles from entering the sample tube. Prior to sampling, the piston is fixed relative to the sample to be obtained. During the actual push, the piston moves with respect to the sampler and helps to pull the sample into the tube and to retain it following the drive. During withdrawal, the piston is again fixed relative to the sampler to aid in sample retention.

The principal use of fixed-piston samplers is for taking undisturbed samples of very soft to stiff clays, silts, and sands both above and below the water table (Goode, 1950). Fixed-piston samplers are particularly adapted to sampling cohesionless sands and soft, wet soils that cannot be sampled using the thin-walled open-tube sampler. These samplers are designed for use in holes stabilized with drilling mud or water because the soil which is being sampled is generally below the water table. Sample tubes with little or no inside clearance ratio, or swage, are generally used with fixed-piston samplers. As is the case with all thin-walled push-tube samplers, the fixed-piston sampler will not successfully sample soils which contain gravel, cemented soil, or soils that are too hard to penetrate.

(i) *Mechanically activated fixed-piston samplers.*

(a) *Hvorslev fixed-piston sampler.* The Hvorslev fixed-piston sampler is a mechanically activated sampler which uses the drill rig hydraulic drive mechanism to advance the sample tube. The sampler head is designed for 7.5-cm- (3-in.-) diam tubes but can be easily converted to use 12.5-cm- (5-in.-) diam tubes with an adapter ring and an enlarged piston assembly. Figure 5-3 is a photograph of the Hvorslev fixed-piston sampler. Figure 5-4 is a cross-sectional view of the sampler.

The operation of the Hvorslev sampler is shown on Figure 5-5. First, the sampler is assembled with the piston locked flush with the bottom of the sampling tube. The sampler is then attached to the drill rods and piston rod extensions and lowered to the bottom of a cleaned borehole. When the sampler contacts

the bottom of the hole, the drill rods are clamped to the hydraulic drive mechanism of the anchored drill rig. The piston rods are rotated clockwise to unlock the piston. The piston rods are then secured to the drill rig mast or a suitable frame independent of the drill rig for sampling operations. To sample, the sampler is advanced into the undisturbed soil in the same manner as described for the thin-walled push-tube sampler. At the end of the push, the piston rods are rotated counterclockwise to lock the piston on the sampler head. Further rotation in a counterclockwise direction causes the piston rods to be disconnected from the sampler. As a result, the piston rods can be removed before the sampler is withdrawn. During withdrawal, the piston remains locked at the top of its stroke by a split cone clamp. Extreme care must be exercised during removal of the sampler from the drill hole to avoid jarring or losing the sample.

The Hvorslev fixed-piston sampler contains many parts and several screw connections. Before attempting to use the apparatus, the operator should thoroughly understand the mechanics, adjustments, and operation of the sampler. Precision parts, such as the piston locking and releasing mechanism and the split cone clamp and spring, are easily damaged by misuse or incorrect assembly. Accurate counting of rotations is required for proper operation and locking and releasing of the piston. As a general rule, the parts of the piston locking and releasing mechanism should be screwed together but not tightened excessively. A gap of 10 to 15 mm (3/8 to 1/2 in.) at the "Coupling with Nut Section" (Figure 5-4) is tightened to set the split cone clamp. Before the device is lowered into the borehole, the sampler should be assembled and checked for proper adjustment and ease of rotation of the locking mechanisms and operation of the device.

(b) *Butters fixed-piston sampler.* The Butters sampler is a simplified version of the Hvorslev sampler which contains fewer parts and screw connections. The Butters sampler has all right-hand threads and a simplified piston rod locking and unlocking mechanism. These features make the sampler much easier to operate. As with the Hvorslev sampler, the Butters sampler is designed for 7.5-cm- (3-in.-) diam push tubes. However, with an adapter ring and an enlarged piston assembly, the sampler is easily converted for use with 12.5-cm- (5-in.-) diam tubes. Figure 5-6 shows a cross-sectional view of the Butters sampler.

To operate, the sampler is assembled with the piston locked flush with the bottom of the sampling tube. The sampler is then attached to the drill rods and the piston rod extensions and lowered to the bottom of a cleaned borehole. When the sampler contacts the bottom of the borehole, the piston rod extensions are clamped to the anchored drill rig. After the piston rod extensions have been clamped, a clockwise rotation of the piston rods unlocks the piston. The piston rod is then secured to the drill rig mast or some other suitable frame which is independent of the drill rig. After the sampler has been advanced into the soil using procedures which are similar to those used for the thin-walled push-tube sampler, the piston rods are then disconnected from the sampler by turning in a counterclockwise direction until the piston rods are free. The piston rods are removed before the sampler is withdrawn. During withdrawal, the piston is held stationary at the top of its stroke by a tension spring and lock washers. Extreme care must be exercised during removal of the sampler from the drill hole to avoid jarring or losing the sample.

The basic rules for operation of the Butters sampler are similar to those of the Hvorslev sampler. Because the Butters sampler contains several parts which require careful assembly for locking and releasing the piston, the mechanics of the sampler should be understood thoroughly by the operator before attempting to sample, as the precision parts can be easily damaged by misuse or incorrect assembly. In general, the parts of the piston rod locking and releasing mechanism should be screwed together snugly, but not tightened excessively. It is also good practice to assemble the sampler and to check its operation before it is lowered into the borehole.

(ii) *Hydraulically activated fixed-piston samplers.*

(a) *Osterberg fixed-piston sampler.* The Osterberg sampler is a hydraulically activated fixed-piston sampler. The design and operation of the hydraulically activated Osterberg sampler is significantly different from the design and operation of the mechanically activated Hvorslev and Butters samplers. Its operation is much faster and simpler than the Hvorslev and Butters samplers because piston rod extensions are not required. Therefore, the Osterberg sampler is much easier to assemble, operate, disassemble, and use. However, there are several disadvantages which include the lack of control for rate of or limit of advancement of the sampler as well as a vacuum breaker was not provided for separating the piston from the tube containing the soil sample. Figure 5-7 is a photograph of the Osterberg sampler. Figure 5-8 illustrates the operation of the sampler.

The Osterberg sampler is commercially available for use with sampling tubes of nominal diameters of 7.5 and 12.5 cm (3 and 5 in.). However, this sampler requires specially designed thin-walled sampling tubes. Conventional thin-walled sampling tubes used for the thin-walled open-drive sampler and the Hvorslev and Butters fixed-piston samplers will not adapt to the Osterberg sampler.

The Osterberg sampler is assembled with the piston flush with the bottom of the sampling tube and attached to the main head of the sampler. The sampler is attached to the drill string and lowered to the bottom of a cleaned borehole. The drill rods are secured to the anchored drill rig, and drilling fluid, under pressure, is pumped through the rods to advance the sampling tube into the undisturbed soil. As fluid pressure is applied to the inner sampler head, the sampling tube is forced out of the pressure cylinder. When the inner sampler head has reached its full stroke (and the sampling tube has penetrated its full depth into the soil), the pressure is relieved through a bypass port in the lower end of the hollow piston rod. An air bubble or return of drilling fluid can be observed at the top of the column of drilling mud which indicates that the sampler has been fully advanced. After the drive, the sampler should be rotated clockwise to shear the sample at the bottom of the sampling tube and to lock the sampling tube in position for withdrawal from the hole. The rotation and locking of the sample tube is accomplished by a friction clutch mechanism which allows the inner sampler head to grasp the inner pressure cylinder when the drill rods are rotated at the ground surface. As the sampler is removed from the borehole, extreme care should be taken to avoid jarring or losing the sample.

Although the Osterberg sampler is relatively simple to operate, the mechanics of the sampler must be thoroughly understood by the operator before attempting to operate the sampler. The sampler contains several moving parts and O-ring seals which require careful assembly and must be kept clean and lubricated for proper operation. As a general rule, the threaded components should be screwed together snugly, but not tightened excessively. The fixed piston should be securely pinned to the hollow piston rod. The inner sampler head should be checked to make sure it slides freely on the hollow piston rod. The use of drilling mud to advance the sampler is not recommended because sand particles suspended in the mud act as an abrasive which may damage the O-ring seals. Therefore, a supply of clear water is desirable for advancing the sampler as well as for rinsing and flushing the sampler after each sampling drive although this may not always be practical in the field environment.

(b) *Modified Osterberg fixed-piston sampler.* The modified Osterberg sampler uses the same basic design and principles of operation as the conventional Osterberg sampler. However, there are several major changes and improvements to the modified Osterberg sampler as compared to the conventional Osterberg sampler. The thin-walled sampling tube was replaced with a thick-walled steel tubing which was machined to accept a commercially available aluminum inner liner. The thick-walled steel tubing is equipped with a case hardened, replaceable drive shoe. Consequently, the modified sampler is

considerably more rigid and better suited for use in soils containing fine gravels. The design of the modified sampler also eliminates the problems associated with removing the sampling tube from the inner sampler head caused by the vacuum developed during the sampling operation. The thick-walled steel tubing has a vent hole to break the vacuum seal and to allow easy removal of the inner liner. The undisturbed sample can be removed from the sampler by simply removing the drive shoe and pulling the liner out of the sampler. The sampler can be reloaded by sliding a new liner into the steel tubing, attaching the drive shoe, and pushing the steel tubing into the pressure cylinder. Although the modified Osterberg sampler is not commercially available, it can be manufactured in 7.5- and 12.5-cm- (3- and 5-in.-) diam sizes.

(c) *Foil and stockinette samplers.* Modified versions of the fixed-piston sampler include the Swedish foil sampler and the Delft stockinette sampler. The principle of operation of these samplers is similar to the fixed-piston sampler. As the sampler is pushed, the piston retracts from the sampler head, and a sliding liner which is attached to the piston is unrolled from its magazine located within the sampler head. Both types of samplers are pushed into the soil without a borehole.

The Swedish foil sampler was developed to obtain long, continuous undisturbed samples in soft cohesive soils (Kjellman, Kallstenius, and Wager 1950). To reduce the friction between the soil sample and the sampler barrel, the sample is progressively encased in thin axial strips of foil as the sampler is advanced. Two diameters of foil samplers are available. The 6.8-cm- (2.7-in.-) diam sampler contains 16 rolls of thin, cold-rolled, mild steel foil in the sampler head. Each roll of foil is approximately 12.5 mm (0.5 in.) wide. The foil is available in thicknesses ranging from 0.05 to 0.12 mm (0.002 to 0.005 in.). The 6.8-cm- (2.7-in.-) diam sampler can store 30 m (100 ft) of foil, while the 4.0-cm- (1.6-in.-) diam sampler can store 12 m (40 ft) of foil. A schematic of the Swedish foil sampler is presented in Figure 5-9.

The Swedish foil sampler consists of a cutter head which is machined to form a sharp edge. The cutter head is attached to the lower end of the sample barrel. The upper end of the cutter head is double-walled and contains a magazine for the rolls of foil. The foil strips pass through small horizontal slots located immediately above the cutter edge and are attached to a loose-fitting piston. During sampling operations, the piston is held stationary at the ground surface to ensure that the foil strips are pulled from the magazine at the same rate as the sampler penetrates the soil.

The foil strips which slide against the inside of the sampler barrel form an almost continuous liner which minimizes the friction between the sampler wall and soil sample. As with the conventional push-tube type samplers, the full advance of the sampler should be made in one fast, smooth, continuous push. However, the effects of the rate of penetration and/or interruptions in pushing are less important. Therefore, additional 2.5 m (8.2 ft) long sections of the sample barrel may be added to extend the length of the sampler.

The original Delft continuous soil sampler was used to obtain a sample 30 mm (1.2 in.) in diameter. As the sampler was pushed into the ground, a nylon stocking-type reinforced plastic skin was unrolled from a magazine in the sampler head to surround the outside of the sample. As the stocking was unrolled, it was coated with a vulcanizing fluid which was stored in a chamber between the stocking tube and the outer barrel of the sampler. When the coated stocking contacted the bentonite-water slurry inside the sampler, the vulcanizing fluid solidified. As a result, the stockinette became a watertight container which prevented lateral strain of the soil sample.

Unfortunately, the bentonite-water slurry in the annulus between the soil sample and sampler sometimes exceeded the in situ stresses, especially in soft soils. As a result, the soil sample and surrounding

formation were disturbed. Consequently, the Delft continuous soil sampler was redesigned. The current version can be used to obtain a 66-mm- (2.6-in.-) diam sample. The sampler uses a stocking-lined plastic liner tube which supports the soil sample during the sampling operations and doubles as the sample storage tube. A schematic of the Delft 66-mm- (2.6-in.-) diam continuous soil sampler is presented in Figure 5-10. The Delft continuous soil sampler is advanced in 3.3-ft (1-m) increments by a cone penetrometer test (CPT) rig. The maximum length of the sample is 19 m (62 ft).

The foil and stockinette samplers were designed to obtain samples with an increased length to diameter ratio which are sometimes required to gain a more comprehensive understanding of a complex soil mass, such as a varved clay, or to obtain samples of soft clay or peat. Although the soil friction inside the sampler is virtually nonexistent, the frictional forces between the foils or stockinette and the inside walls of the sampler and between the soil and outside walls of the sampler can become so great as to prohibit pushing the sampler. Lubricants have been used between the liners and sampler for cohesive soils, but should not be used for cohesionless soils as they may penetrate the sample and prohibit its use. Friction between the soil and the outside of the sampler has been reduced by the use of a rotary outer core barrel which has cutter teeth and the capability of circulating a drilling fluid. The principal disadvantages of the foil and stockinette samplers include larger operating expenses and the increased potential for sample disturbance due to the larger area ratio of the cutting shoe.

b. Core barrel samplers. Double- and triple-tube core barrel samplers consist of a sampler head assembly, inner and outer tubes, and a bottom assembly. The triple-tube core barrels are merely double-tube samplers which have been modified to accept sample liners. The principle of operation of the core barrel samplers consists of rotating a cutting bit by a torque which is applied at the ground surface by the drill rig and transmitted downward through the drill rods to the cutting bit. As the cutting edge is advanced, a sampling tube is pushed over the sample. The sampler head assembly has a ball-bearing-supported cap and stem which allows the inner tube to remain relatively stationary as the outer barrel is rotated. Drilling fluid is passed downhole through the drill rods and between the inner and outer barrels before being discharged under the bit.

There are three basic types of core barrel soil samplers: Denison, Pitcher, and hollow-stem auger samplers. The Denison and Pitcher samplers are similar in design and operation. These samplers require the use of drilling fluid to remove the cuttings from the face of the bit. The hollow-stem auger sampler which is discussed in paragraph 5-1c(1) does not require drilling fluid; therefore, is well suited for sampling soils that are adversely affected by drilling fluids. Sample liners for handling and shipping the soil cores can be used with the Denison and hollow-stem auger samplers.

Core barrel samplers may have a larger area ratio and inside clearance ratio than is generally accepted for push-tube samplers. Double- and triple-tube core barrel samplers are available in standard sizes ranging from 7.0-cm (2-3/4-in.) ID by 9.8-cm (3-7/8-in.) OD to 15.2-cm (6-in.) ID by 19.7-cm (7-3/4-in.) OD. The larger area ratios may be considered advantageous as the stresses at the cutting head are decreased during the drilling operations. However, the larger inside clearance ratio due to a core catcher may not adequately support the sample. The sample may also be damaged by vibrations of the cutting bit during the drilling operations. Another disadvantage is that water sensitive formations may be continuously in contact with the drilling fluid.

Core barrel samplers may be used for sampling a broad range of soils. These samplers can be used for obtaining reasonably undisturbed samples of stiff cohesive soils. Firm or dense samples of uncemented or lightly cemented silty or sandy soils can often be obtained if sampling and handling of the samples are done carefully. However, when it is unknown whether the deposit is dense or loose, other samplers, such

as fixed-piston samplers, should be tried as the core barrel samplers tend to densify loose soils during the sampling operations. Core barrel samplers may also be used in fairly firm to hard or brittle soils, partially cemented soils, and soft rock which require a cutting action rather than simply a push-type penetration. In general, core barrel samplers, such as the Denison and Pitcher samplers, are not suitable for sampling loose cohesionless sands and silts below the groundwater table, very soft and plastic cohesive soils, or severely fissured or fractured materials.

(1) *Denison sampler.* The Denison sampler is a double-tube (triple-tube if a liner is used) core-barrel type sampler designed for sampling coarse sands, gravel and gravelly soils, and clays and silts that are too hard to sample with thin-walled push-tube samplers. The sampler consists of an outer barrel with cutting teeth, an inner barrel with a smooth cutting shoe, and a liner to receive the sample and to facilitate sample handling. The inner barrel may be equipped with a spring core catcher, if necessary. Denison samplers are available in 10.0- and 15.0-cm- (4- and 6-in.-) nominal diameter core sizes. The length of the cores are 0.6 m (2 ft). A photograph of a Denison double-tube core barrel sampler is presented in Figure 5-11. A schematic diagram of the sampler is shown in Figure 5-12.

The Denison sampler is advanced in the borehole using drilling rod and drilling fluid. The outer barrel head contains an upper and lower bearing which allows the outer barrel to be turned by the drilling rod while the inner barrel remains stationary. Carbide insert cutting teeth are attached to the bottom of the outer barrel. Four 1.25-cm- (1/2-in.-) diam fluid passages are used for circulation of drilling fluid from the drill rods into the annulus between the inner and outer barrels to the cutting teeth. Four 1.25-cm- (1/2-in.-) diam holes are also provided in the outer barrel head to vent the inner barrel and to stabilize the hydrostatic pressure within the sampler.

The Denison sampler may be fitted with inner barrel shoes of various lengths. This shoe arrangement effectively permits the inner barrel to be extended beyond the cutting bit, especially for coring and sampling easily eroded material. The inner barrel may be extended as much as 15.0 cm (6 in.) past the cutting bit, although an extension no greater than 7.5 cm (3 in.) is recommended. Unfortunately, the principal disadvantage of this type of sampler is that the protrusion of the inner tube must be selected and/or adjusted in advance of the sampling operations for the anticipated stiffness of the soil to be sampled. This disadvantage led to the development of core barrel samplers with the spring-mounted inner barrel.

A light gauge metal liner which can be used as a sampling tube to preserve the soil sample for shipment can be fitted into the inner barrel of the Denison sampler. The liner is typically made of 28-gauge (0.38-mm) sheet metal. The length of the liner should be 60 cm (24 in.); this length will permit a 50-cm- (20-in.-) long sample to be obtained. A core catcher may or may not be used for undisturbed sampling operations. However, if a core catcher must be used to retain the soil in the sampler, it should be noted on the boring logs.

(2) *Pitcher sampler.* The Pitcher sampler is a double-tube core barrel sampler which is a variation of the Denison sampler. The inner barrel which is affixed to a spring-loaded inner sampler head extends or retracts relative to the cutting bit on the outer barrel with changes in soil stiffness. The telescoping action of the sampling tube eliminates the need for various lengths of inner barrel shoes. The nominal core sizes which can be obtained with standard Pitcher samplers are 75-, 100-, and 150-mm (3-, 4-, and 6-in.) diameter with lengths of 0.9 or 1.5 m (3 or 5 ft). Figure 5-13 is a photograph of a Pitcher double-tube core barrel sampler. A schematic drawing of the operation of the Pitcher sampler is presented in Figure 5-14.

The Pitcher sampler contains a high-tension spring which is located between the inner and outer barrels above the inner head. The spring-loaded inner barrel assembly automatically adjusts the relative position of the cutting edge of the sampling tube to suit the formation being sampled. For example, in softer formations, the spring extends so that the inner barrel shoe protrudes into the soil below the outer barrel bit and prevents damage to the sample by the drilling fluid and drilling action. For stiffer soils, the sampling tube is pushed back into the outer barrel by the stiff soil. In extremely firm soils, the spring compresses until the cutting edge of the inner barrel shoe is flush with the crest of the cutting teeth of the outer barrel bit. Although it has been observed in practice that alternating soil and rock layers sometimes damage the rather light sampling tube, the Pitcher sampler is recommended for sampling varved soils, formations where the stratigraphy is such that there are alternating hard and soft layers, or soils of variable hardness.

A sliding valve arrangement between the outer barrel head and inner barrel head directs drilling fluid through the sampler. After the sampler has been lowered into the borehole but before it has been seated on the soil, debris can be flushed from the sample tube by drilling fluid which is passed down the drill rods through the inner barrel. Once the inner tube is seated, the barrel telescopes inward and the drilling fluid is diverted to the annulus between the inner and the outer barrels. This arrangement facilitates the washing of material from the inside of the sampler before sampling and circulation of drilling fluid to remove cuttings during sampling.

(3) *WES modified Denison sampler.* A special sampler was developed by the U.S. Army Engineer Waterways Experiment Station (WES) to obtain samples of hard or gravelly soils and rock. The sampler incorporates principles used in the Denison core barrel sampler; hence, it is called the modified Denison sampler. The sampler was designed to obtain an undisturbed sample in a 127-mm- (5.01-in.-) ID by 133-mm- (5.25-in.-) OD steel tube that could later be cut in sections for testing without removal of the soil from the tube. The sampler consists of a standard DCDMA 100-mm (4-in.) by 140-mm (5.5-in.) core barrel head adapted to a 150-mm- (6-in.-) OD outer barrel and a standard 125-mm (5-in.) by 11-gauge (3-mm) sample tube. Two outer barrel cutting shoe arrangements permit the inner barrel cutting edge to lead or to follow the outer barrel cutting shoe. An inner barrel adapter is provided with spacers to vary the relative positions of the two barrels. Core barrels with internal or bottom discharge bits set with tungsten carbide teeth are satisfactory for drilling and sampling most stiff to hard soils. The cutting teeth are set at 20 to 30 deg with respect to the radius to cause a slicing action which tends to force the cuttings and drilling fluid away from the core. The bottom assembly can be fitted with an inner tube extension and cutting shoe. Bottom assemblies are also available which permit the use of basket-type or split-ring core lifters to prevent the loss of the core during the extraction process. A third cutting shoe arrangement allows the use of a diamond bit and a split-ring core lifter. The nominal core size is 125 mm (5 in.) in diameter by 0.76 m (2.5 ft) in length.

c. Other samplers. A number of other samplers suitable for obtaining undisturbed samples are available from commercial sources. Generally, each sampler was designed to be used in specific types of soils or to satisfy specific conditions. However, most of these samplers are variations of either the thin-walled piston-type samplers or the core barrel samplers.

(1) *Hollow-stem auger sampler.* The continuous hollow-stem auger sampling system consists of a rotating outer hollow-stem auger barrel which is equipped with cutting bits at its bottom and a nonrotating inner barrel (sampler) fitted with a cutting shoe. The principle of operation is similar to the rotary core barrel sampler. The stationary inner barrel slides over the sample in advance of the rotating outer bit which enlarges the hole above the sample. The cuttings are lifted from the hole by the auger

flights on the outer barrel. A schematic drawing of the hollow stem auger with a thin-walled sampling tube is presented in Figure 5-15.

The hollow-stem auger barrel acts as a casing in the borehole. It is defined by pitch, flight, outside diameter, and inside diameter. Augers range in diameters from 57 mm (2-1/4 in.) to 210 mm (8-1/4 in.), or larger. A table of common diameters of flight augers is presented as Table 5-1. The hollow-stem auger barrel is advanced by downward pressure to clean the hole and rotation to bring the cuttings to the surface. Excessive downfeed pressure may cause the auger to corkscrew into the ground. As a result, the auger could bind in the hole. Additional sections of auger can be added as the borehole is advanced.

The cutting bits on the hollow-stem auger barrel are equipped with 4 to 12 cutting teeth which are fitted with replaceable carbide inserts. The ID of the cutting bits allows clearance for passage of the inner barrel. During sampling operations, the inner barrel is pinned to and advanced with the hollow-stem auger. The inner barrel may be positioned in front of or kept even with the auger cutting bits with an adjustment rod. Minimal disturbance to the sample is caused when the inner barrel is advanced in front of the cutting teeth by approximately 75 mm (3 in.). When the inner barrel is advanced in front of the cutting teeth by less than 75 mm (3 in.), disturbance may occur because of the ripping action of the auger cutting teeth.

The inner barrel assembly contains a sampler head and liner. The inner barrel assembly can be fitted with one 1.5-m (5-ft) liner section or two 0.76-m (2-1/2-ft) liner sections. The liners can be acrylic or metal. Acrylic tubing is economical and permits visual inspection of the sample. It is reusable but should be checked for cracks, roundness, and wall thickness before reuse. Metal liners generally have less wall friction than acrylic liners.

The liners are held in the inner barrel assembly by a cutting shoe which is threaded onto the inner barrel assembly. The cutting shoes may be machined with different inside clearance ratios. (See paragraph 2-3*b* for the inside clearance ratio calculation procedure.) The selection of the inside clearance ratio of the cutting shoe will depend on the soil to be sampled. In general, smaller inside clearance ratios should be used for cohesionless soils, whereas larger clearance ratios should be used as the plasticity of the material increases.

Continuous sampling is possible as the auger advances the borehole. When sampling is not required, a center bit can be used to keep soil out of the hollow stem of the auger. The center bit is a left-handed auger which forces the parent material down and to the outside of the main auger barrel, thereby allowing the main auger barrel to carry the cuttings to the surface. The center bit can be replaced with the inner barrel assembly at any time or depth to permit samples to be taken.

The principal advantages of the continuous hollow-stem auger sampling system include advancing the borehole in dry materials without drilling fluid or in unstable materials without casing. Whenever augering operations are conducted below the water table, hydrostatic pressures should be maintained at all times inside the hollow stem to prevent heaving and piping at the bottom of the borehole. If the center plug is used, O-rings should be used to keep water out of the auger stem.

An alternative method of sampling with a hollow-stem auger consists of advancing the borehole by augering with a center drag bit attached to the bottom of the auger. At the desired sampling depth, the center bit is removed, and a suitable sampling apparatus is lowered through the auger to obtain a sample. For this particular application, the hollow-stem auger is used as a casing. Figure 5-16 is a photograph of

a hollow-stem auger with a center drag bit. An isometric drawing of the hollow-stem auger with the center drag bit which can be used with soil sampling devices is presented in Figure 5-17.

(2) *Sand samplers.* Obtaining undisturbed samples of sand has been rather difficult and elusive. In general, the in situ stresses are relieved by sampling operations and frequently, the sand structure has been disturbed and sometimes destroyed. Hvorslev (1949) suggested several methods including the use of thin-walled fixed-piston samplers in mudded holes, open-drive samplers using compressed air, in situ freezing, or impregnation. USAEWES (1952) and Marcuson and Franklin (1979) reported that loose samples were densified and dense samples were loosened when the thin-walled fixed-piston sampler was used. Seed et al. (1982) reported that the Hvorslev fixed-piston sampler caused density changes, while the advanced trimming and block sampling technique caused little change in density, although some disturbance due to stress relief was reported. Singh, Seed, and Chan (1982) reported a laboratory study which indicated that the in situ characteristics, including the applied stress conditions, could be maintained in a sandy soil if the material was frozen unidirectionally without impedence of drainage and sampled in a frozen state. Equipment and procedures for drilling and sampling in frozen formations are presented in Chapter 9; suggested equipment and procedures for artificial freezing of in situ deposits of cohesionless soils are presented in Appendix D. Schneider, Chameau, and Leonards (1989) conducted a laboratory investigation of the methods of impregnating cohesionless soils. They reported that the impregnating material must readily penetrate the soil and must be easily and effectively removed at a later date. Because of these limitations, they also concluded that although the impregnation method could be used in the field environment, the methodology was better suited to the laboratory environment.

Bishop (1948) developed a 63-mm- (2-1/2-in.-) diam thin-walled open-drive sampler which was specifically designed for sampling sand. The sampler was equipped with vents and a diaphragm check valve. Figure 5-18 is a schematic diagram of the Bishop sand sampler. A drawing which illustrates the operation of the Bishop sampler is presented in Figure 5-19. The entire sampler was encapsulated in a compressed air bell which was connected to an air compressor at the ground surface. To operate, the sampler with compressed air bell was lowered to the bottom of a cleaned borehole. The sampling tube was pushed out of the air bell and into the undisturbed soil. After the drilling rods had been disconnected from the sampler and removed from the borehole, compressed air was pumped into the bell. When air bubbles began rising to the surface through the drilling fluid, all of the drilling fluid had been forced out of the compressed air bell. The sampling tube with the sample was pulled from the in situ formation into the bell, and the entire assembly was quickly returned to the ground surface by a cable. Bishop used the principles of arching and capillary stresses at the air-water interface of the sand to retain the sample in the tube and to reduce sample losses.

Vibratory samplers have been used to obtain samples of saturated fine sands and silts. The principle of sampling by vibratory methods consists of liquefying the material in the immediate proximity of the sampling rather than applying brute force to advance the tube. Because of the liquefaction of the material near the sampling tube, the sample is severely disturbed. Consequently, the vibratory sampling method is not satisfactory for obtaining undisturbed samples of sands.

5-2. Sample Tubes

a. Diameter. The size of specimen required for the laboratory testing program shown in Table 2-5 dictates the minimum acceptable sample tube diameter. Generally, a 125-mm (5-in.) ID tube should be used for sampling cohesive soils, whereas a 75-mm (3-in.) ID tube should be used for sampling cohesionless soils. Figure 5-20 is a photograph of 75- and 125-mm- (3- and 5- in.-) diam sampling tubes. The smaller diameter tubes are normally used for sampling cohesionless materials because the

penetration resistance of the 125-mm (5-in.) tubes in dense cohesionless soils generally exceeds the driving capacity of the drill rig. Furthermore, the sample recovery ratio for cohesionless materials is frequently higher when the 75-mm (3-in.) ID tube is used because of arching of the material in the sample tube. Although larger samples are sometimes required for special testing programs, 75- and 125-mm- (3- and 5-in.-) diam sampling tubes should be used to the extent possible to permit standardization of sampling equipment and procedures and to ensure that sample sizes are compatible with laboratory testing equipment and requirements.

b. Length. Sample tubes must be long enough to accommodate the sampler head and piston of the given sampling apparatus and to obtain a sufficient length of sample. Typically, the length of the sample tube is about 0.9 m (3 ft) which is sufficient for obtaining a 0.75-m- (2.5-ft-) long sample.

c. Area ratio. As discussed in paragraph 2-3, the sample tube wall should be as thin as practical but strong enough to prevent buckling of the tube during sampling. Sample tubes of 125-mm (5-in.) ID by 11-gauge (3-mm) wall thickness or 75-mm (3-in.) ID by 16-gauge (1.5-mm) wall thickness cold-drawn or welded and drawn-over-the-mandrell seamless steel tubing provide adequate strength and an acceptable area ratio. The area ratio for a 125-mm (5-in.) ID by 11-gauge (3-mm) sample tube with a 1.0 percent swage is approximately 12 percent. The area ratio for a 75-mm (3-in.) ID by 16-gauge (1.6-mm) sample tube with 0.5 percent swage is approximately 10 percent.

d. Cutting edge. The sample tube for undisturbed samples should have a smooth, sharp cutting edge free from dents and nicks. The cutting edge should be formed to cut a sample 0.5 to 1.5 percent smaller than the ID of the sample tube. As discussed in paragraph 2-3, the required clearance ratio, or swage, must be varied for the character of the soil to be sampled. Sticky, cohesive soils require the greatest clearance ratio. However, swage should be kept to a minimum to allow 100 percent sample recovery.

e. Material.

(1) *Tubing.* Sampling tubes should be clean and free of all surface irregularities including projecting weld seams. Cold-drawn seamless steel tubing provides the most practical and satisfactory material for sample tubes. Generally, tubing with a welded seam is not satisfactory. However, welded and drawn-over-the-mandrel steel tubing is available with dimensions and roundness tolerances satisfactory for sample tubes. Brass or stainless steel tubing is also satisfactory provided that acceptable tolerances are maintained. However, the extra cost for brass or stainless steel tubing is justified only for special projects.

(2) *Coating.* Steel sampling tubes should be cleaned and covered with a protective coating to prevent rust and corrosion which can damage or destroy both the unprotected tube and sample. The severity of the damage is a function of time as well as the interaction between the sample and the tube. Hence, the material to be sampled may influence the decision regarding the type of coating which is selected. It is also noteworthy that the protective coating helps to form a smoother surface which reduces the frictional resistance between the tube and the soil during sampling operations.

Coatings may vary from a light coat of oil, lacquer, or epoxy resin to teflon or plating of the tubes. Alternate base metals for the tubes should also be considered for special cases. Mathews (1959) describes the results of tests conducted at WES on a variety of sample tube coatings. A photograph of a dipping tank for coating 75- and 125-mm- (3- and 5-in.-) diam sampling tubes is illustrated in Figure 5-21.

Table 5-1
Auger Sizes (Diameters) (after Acker 1974)

| Hole Diameter | | Auger Flighting (OD) | | Auger Axle (ID) | | Sampling Tools | | Core Barrels |
|---------------|----------|----------------------|---------|-----------------|---------|----------------|---------|------------------------------------------------------|
| mm | (in.) | mm | (in.) | mm | (in.) | mm | (in.) | |
| 159 | (6-1/4) | 127 | (5) | 57 | (2-1/4) | 51 | (2) | AWG |
| 171 | (6-3/4) | 146 | (5-3/4) | 70 | (2-3/4) | 64 | (2-1/2) | BWG |
| 184 | (7-1/4) | 159 | (6-1/4) | 83 | (3-1/4) | 76 | (3) | NWG |
| 337 | (13-1/4) | 305 | (12) | 152 | (6) | Denison | | 102 by 140
(4 by 5-1/2)
Core Barrel
Sampler |

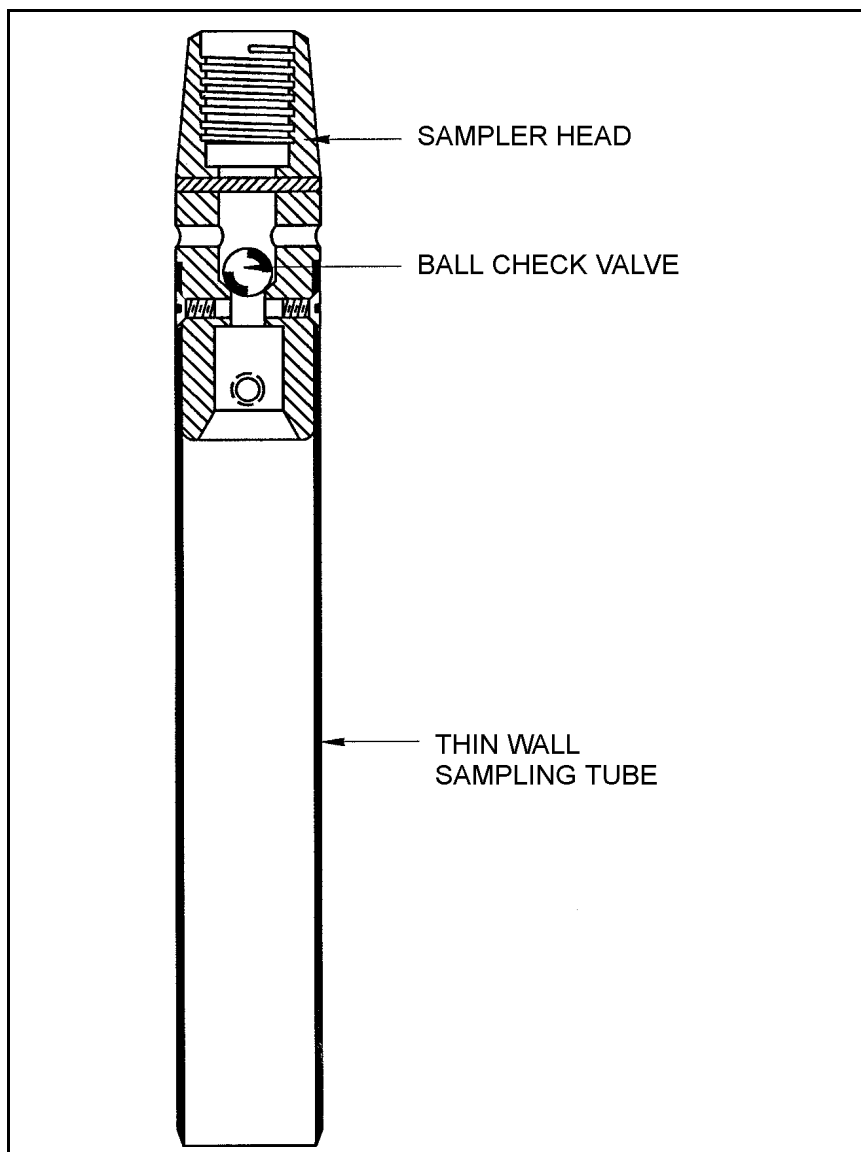

Figure 5-1. Schematic drawing of an open-tube sampler

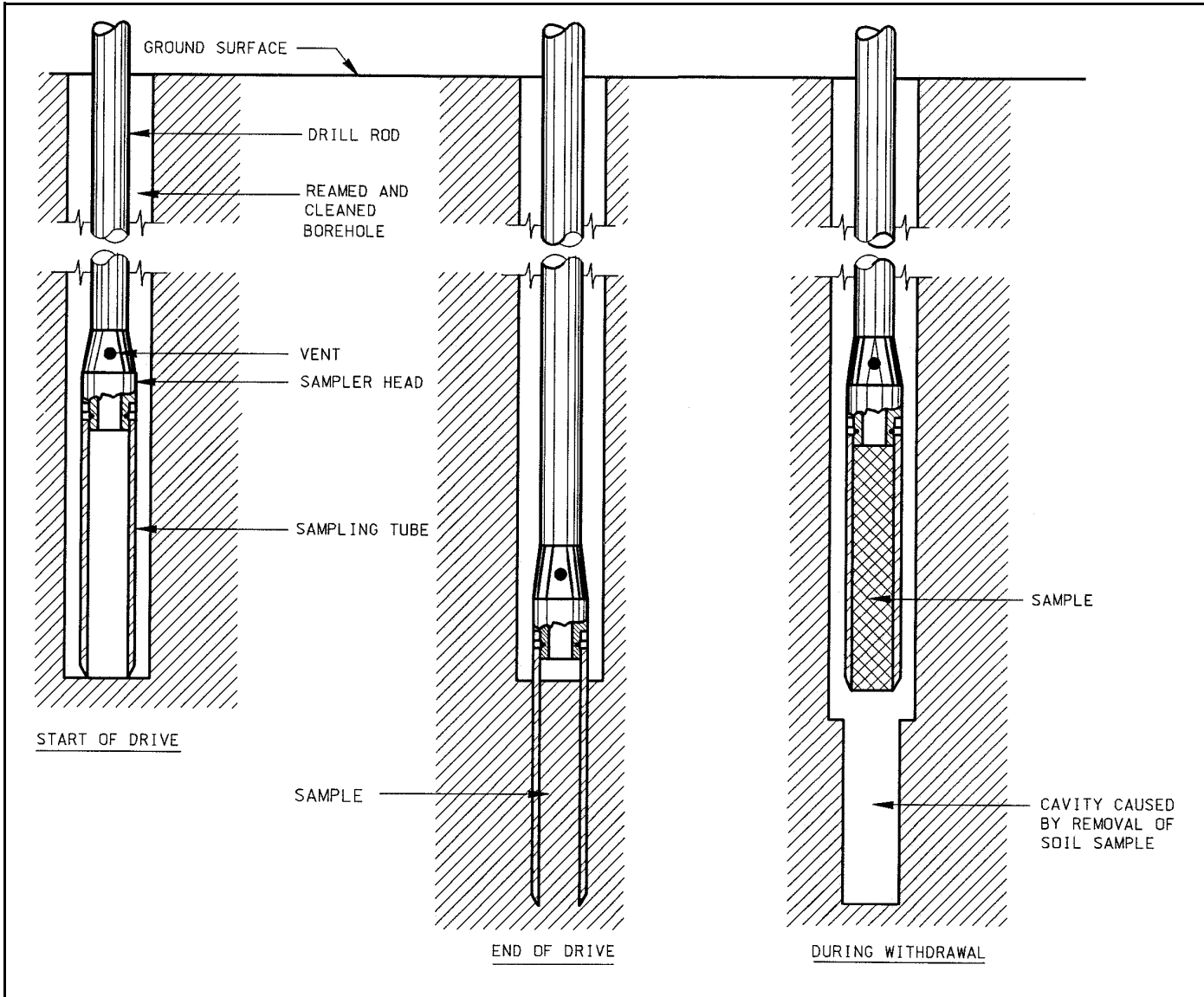

Figure 5-2. Diagram of sampling operations using the open-tube sampler

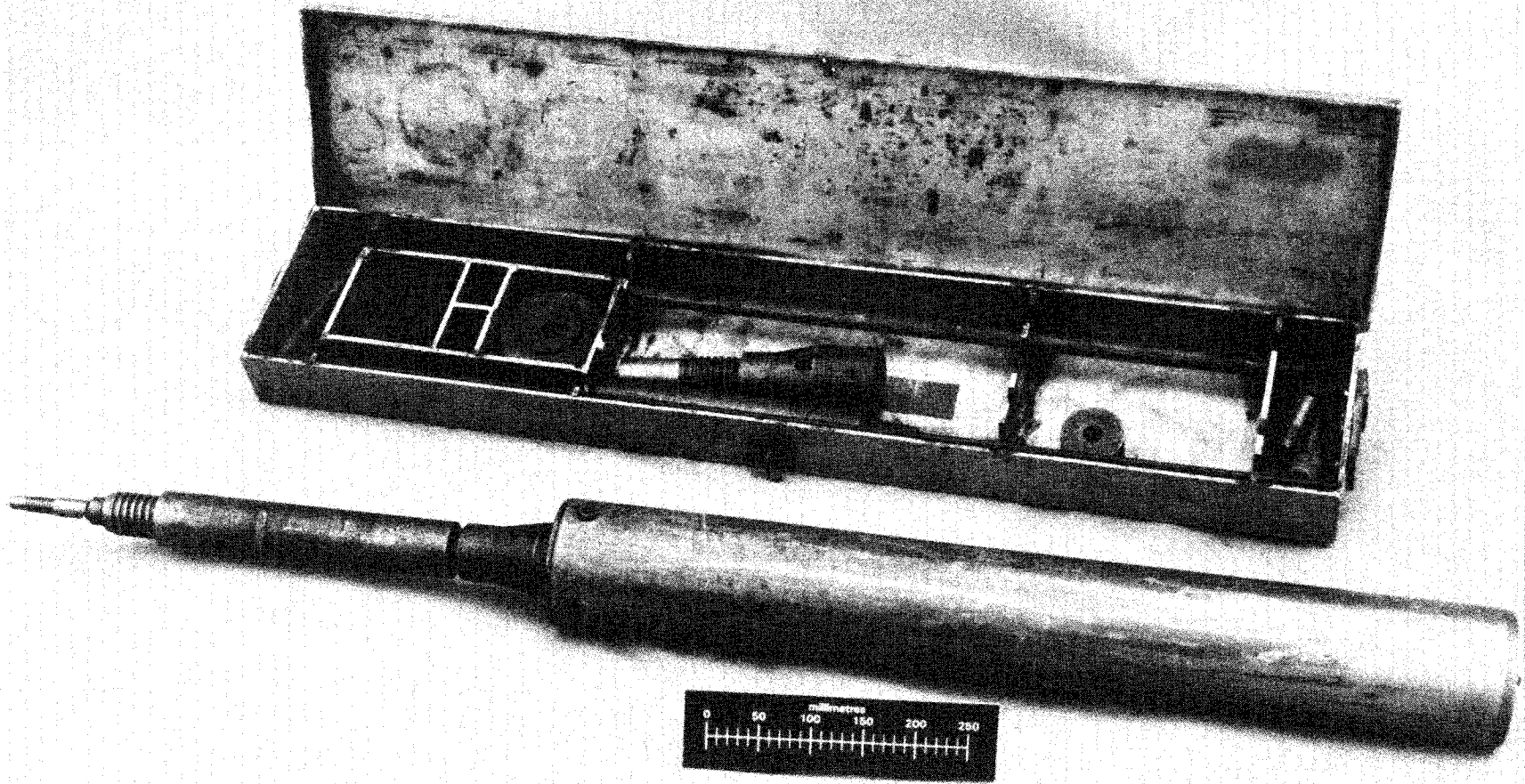

Figure 5-3. Photograph of the Hvorslev fixed-piston sampler

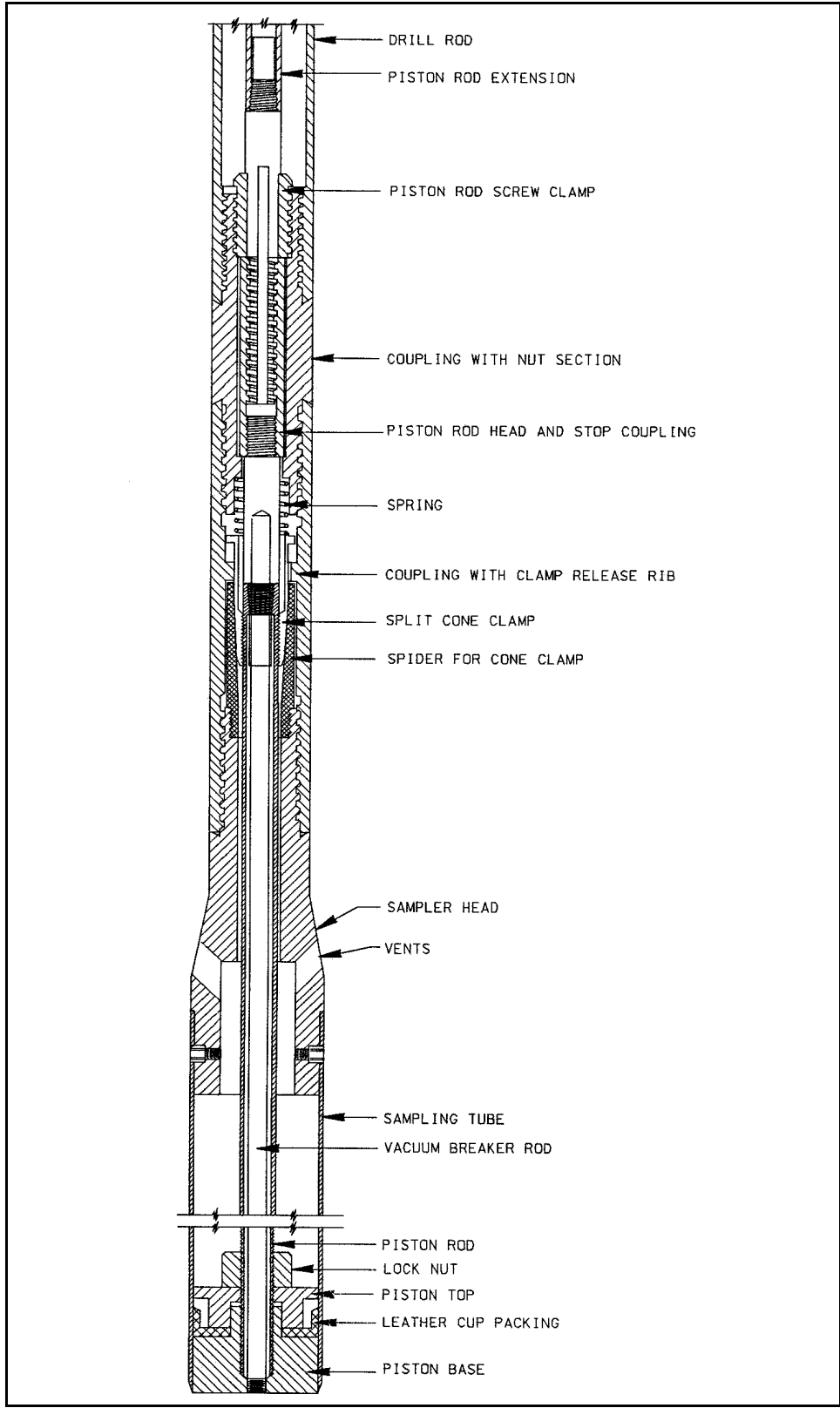

Figure 5-4. Cross-sectional view of the Hvorslev fixed-piston sampler

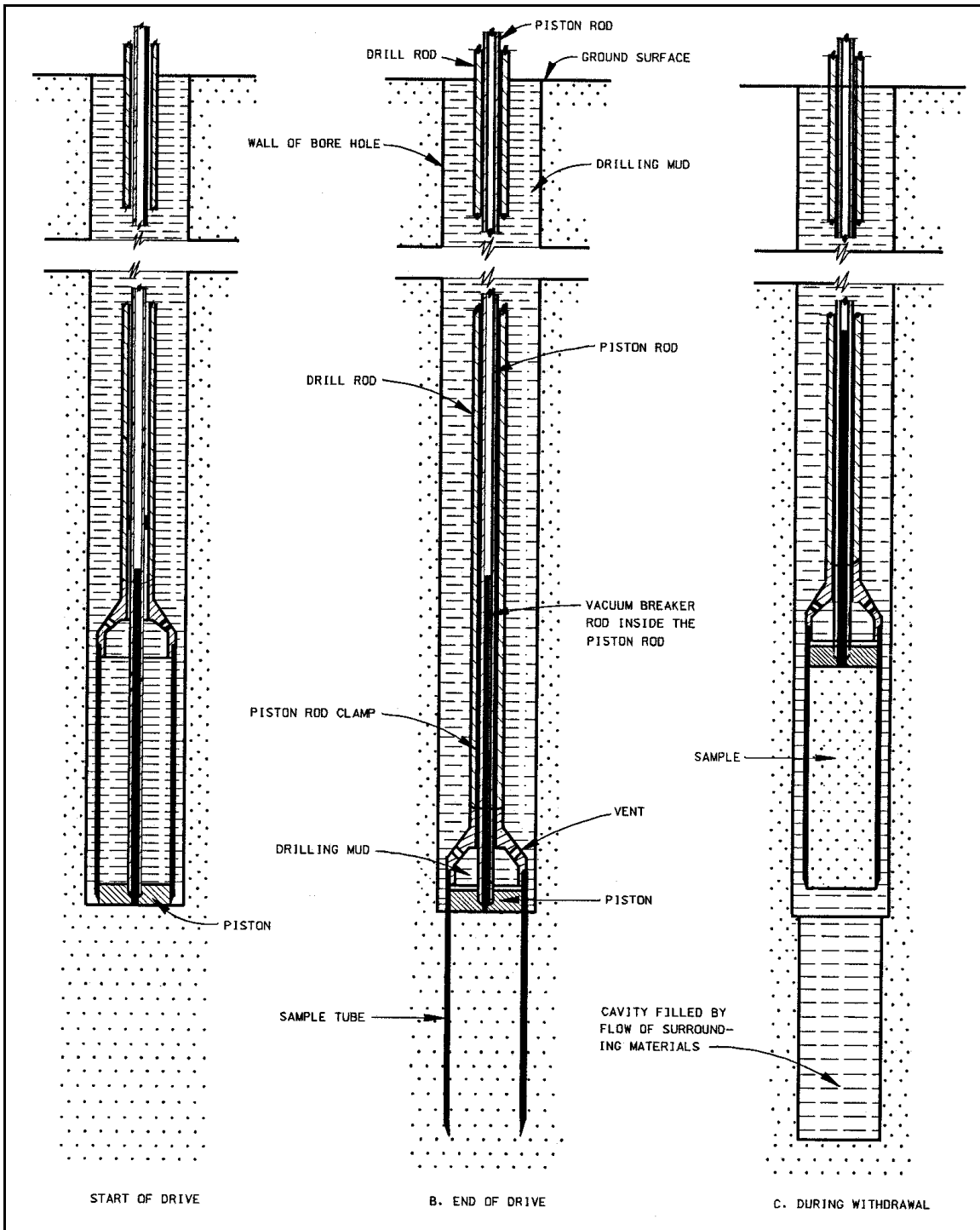

Figure 5-5. Schematic diagram of the operation of the Hvorslev sampler

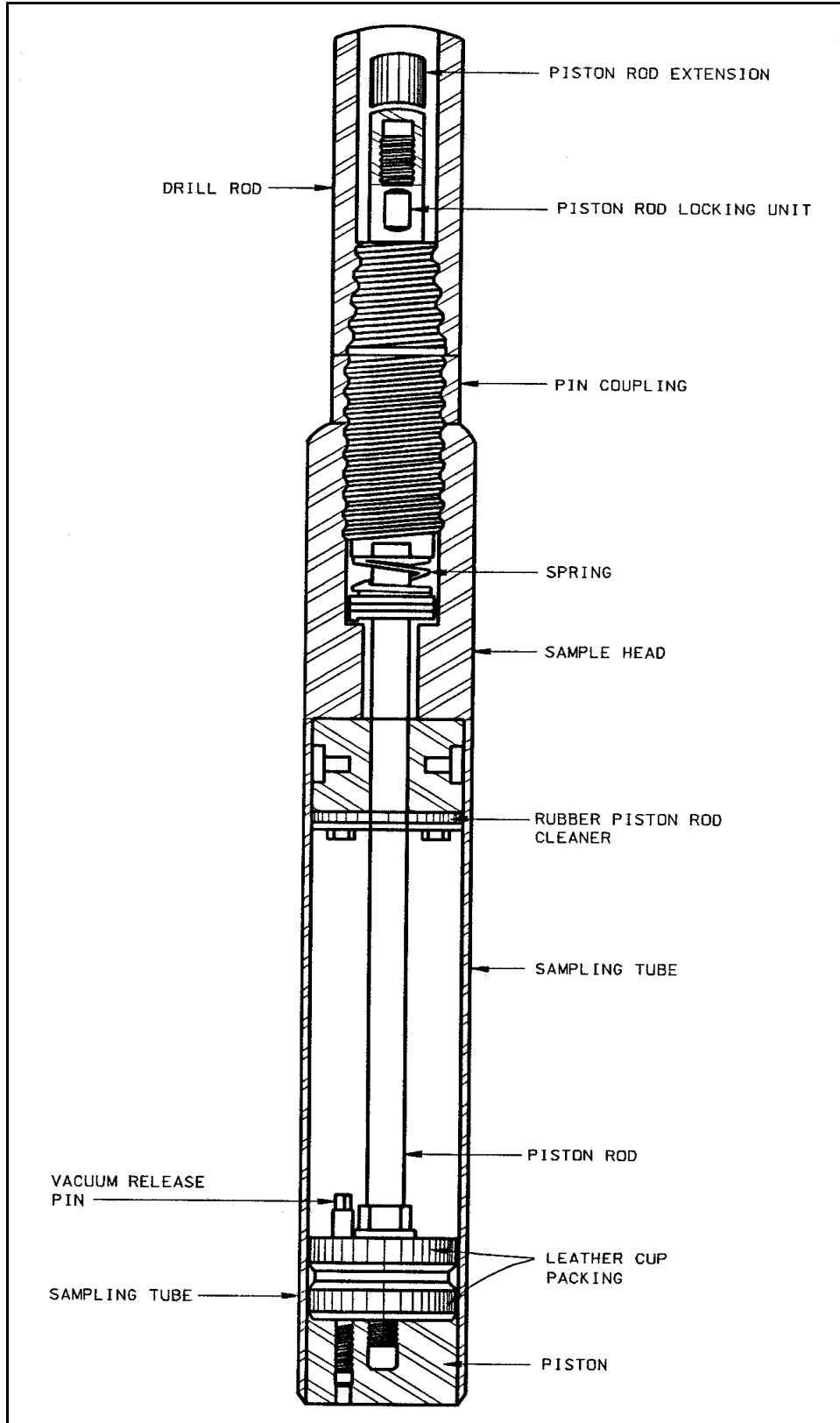

Figure 5-6. Cross-sectional diagram of the Butters samplers (after U.S. Department of the Interior 1974)

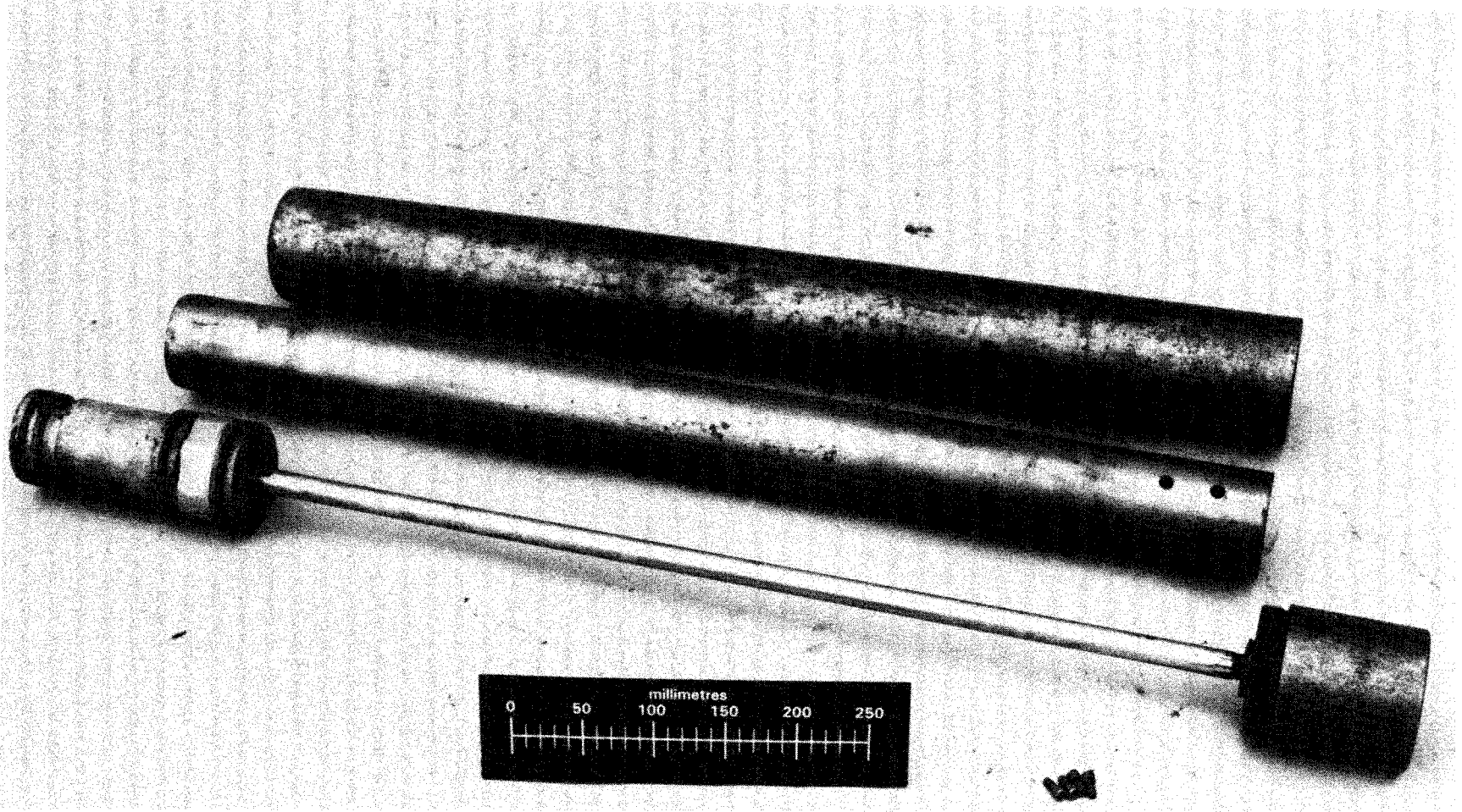

Figure 5-7. Photograph of the Osterberg sampler

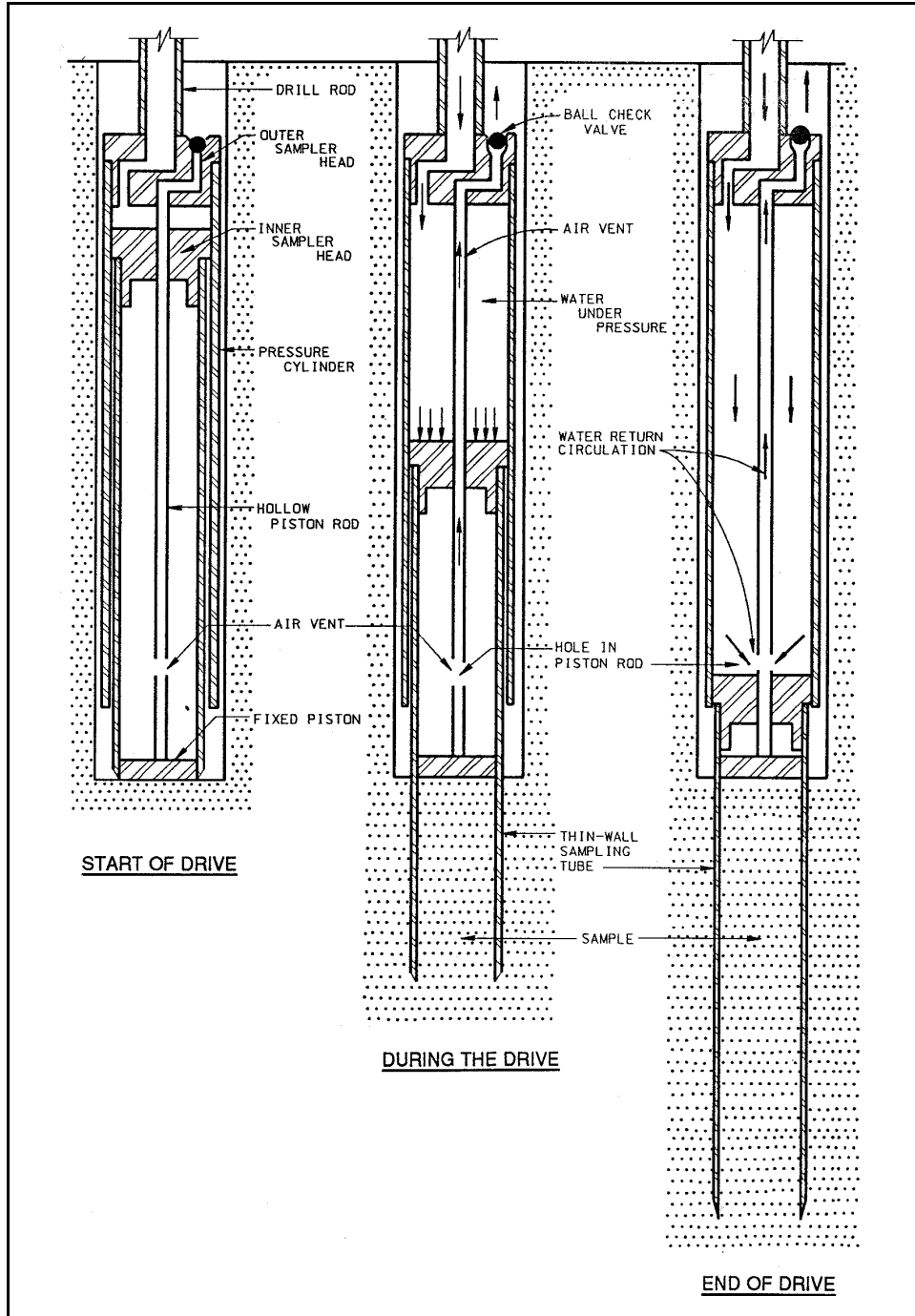

Figure 5-8. Cross-sectional view of the Osterberg sampler which illustrates the operation of the sampler (after U.S. Department of the Interior 1974)

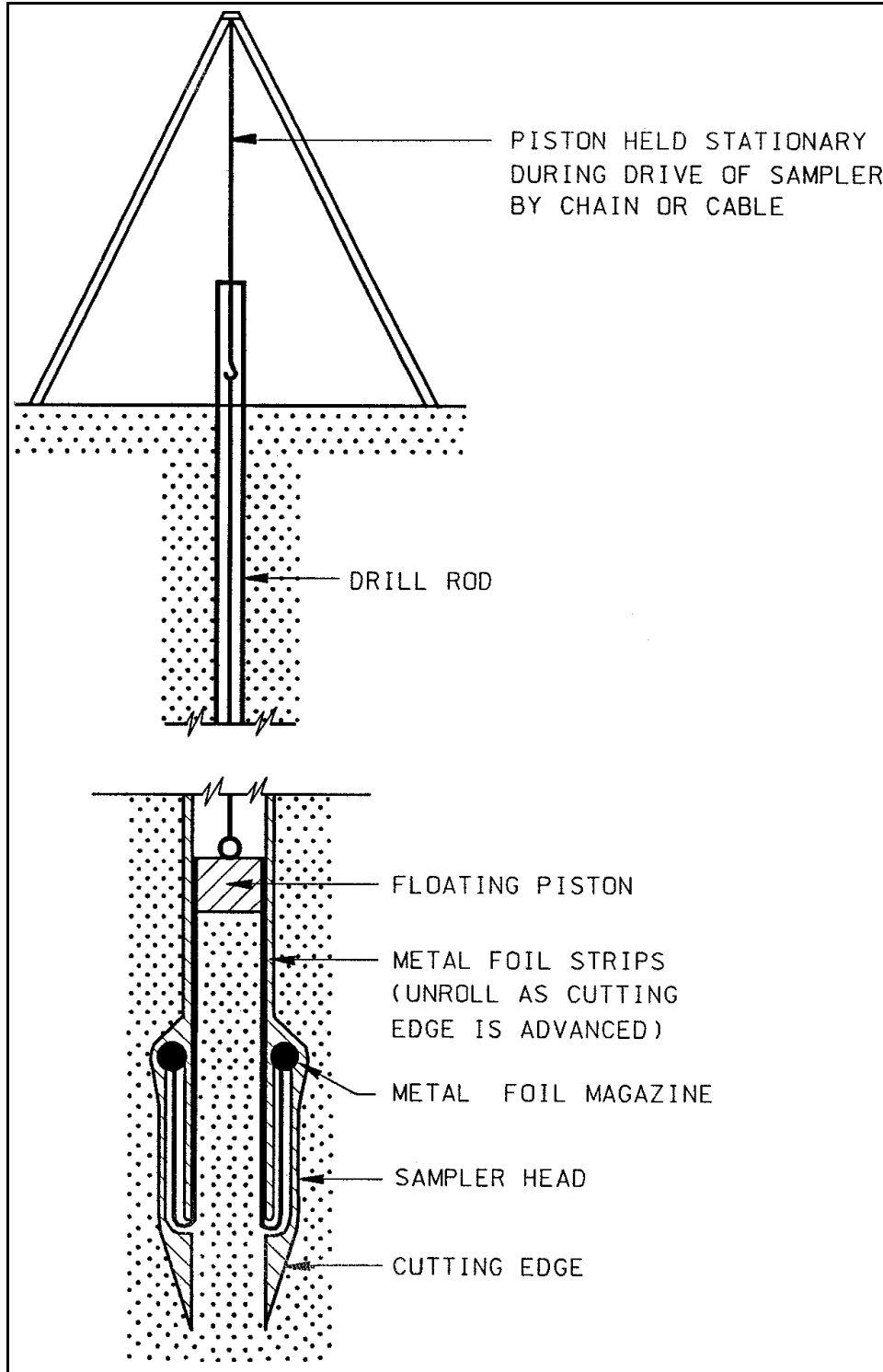

Figure 5-9. Schematic diagram of the Swedish foil sampler

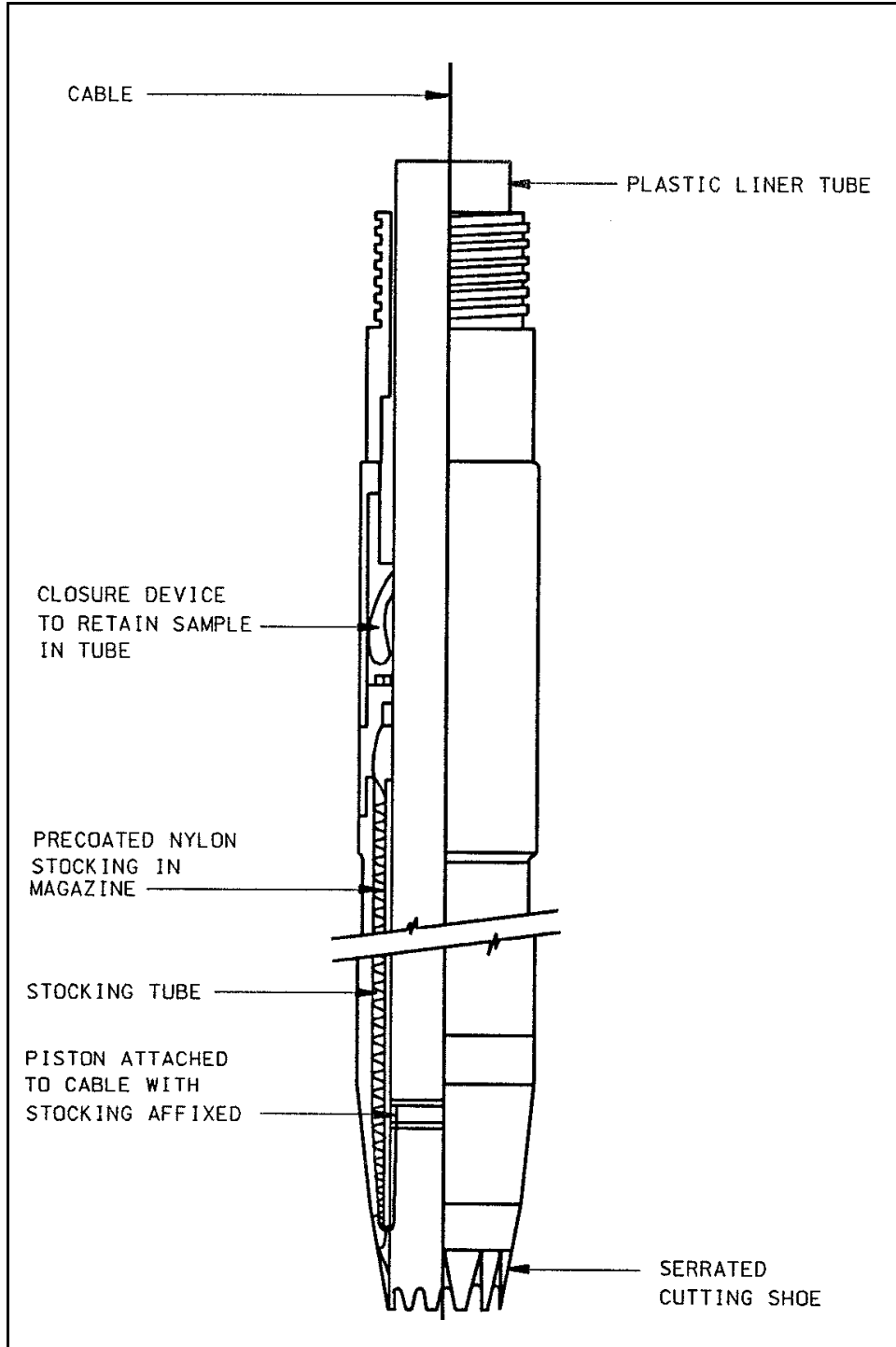

Figure 5-10. Schematic diagram of the Delft continuous soil sampler

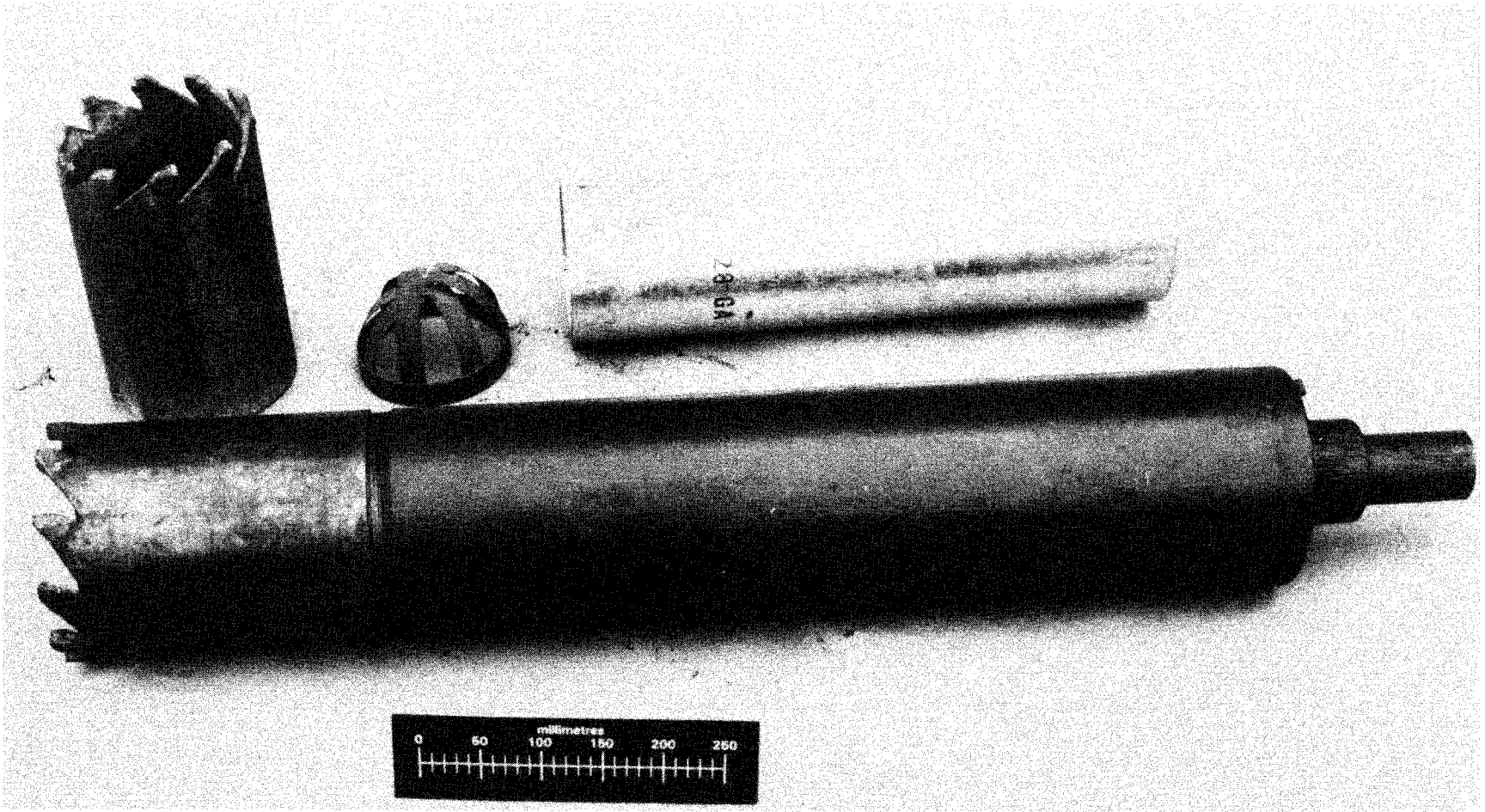

Figure 5-11. Photograph of the Denison sampler

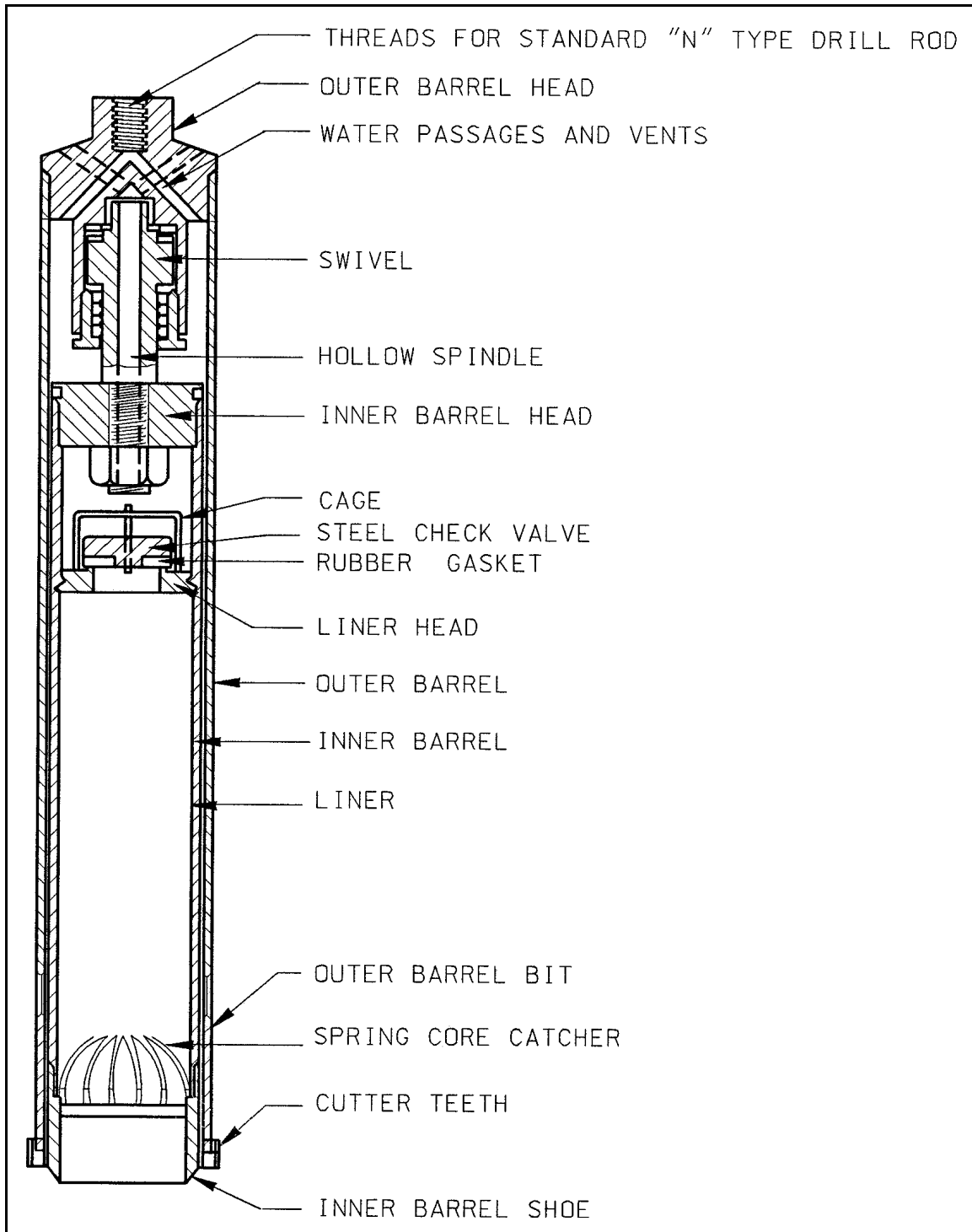

Figure 5-12. Schematic diagram of the Denison sampler (after Hvorslev 1949)

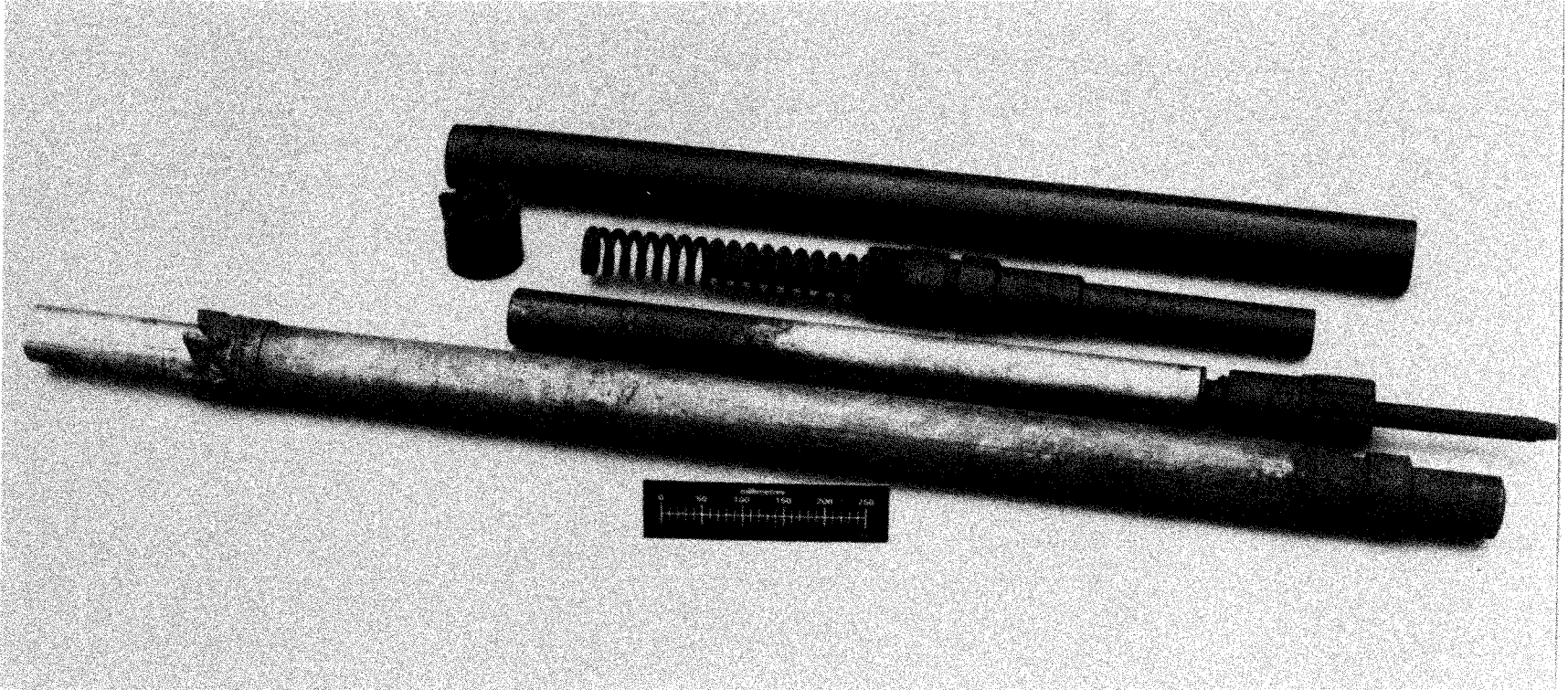

Figure 5-13. Photograph of the Pitcher double-tube core barrel sampler

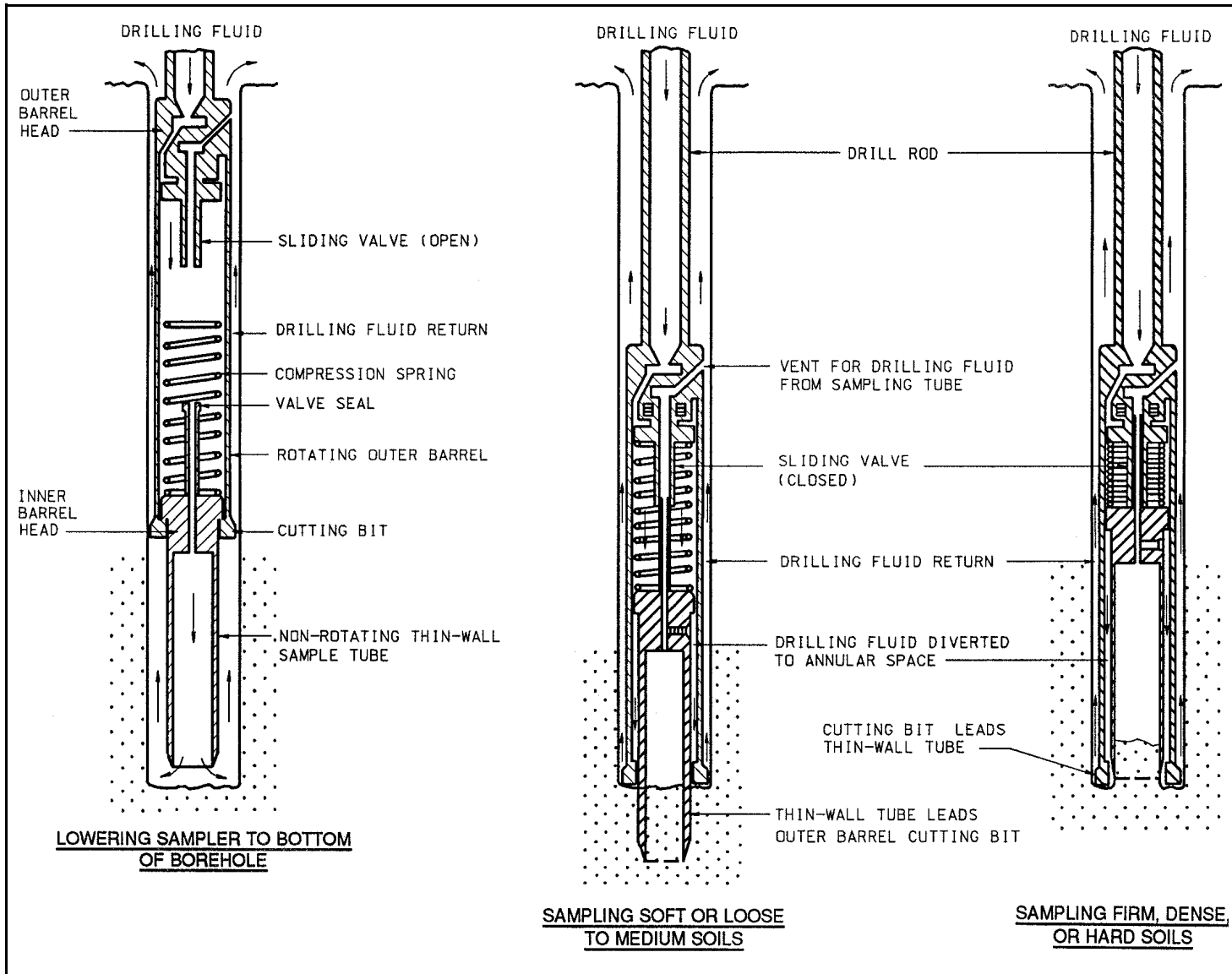

Figure 5-14. Schematic drawing of the operation of the Pitcher sampler (after (Winterkorn and Fang 1975))

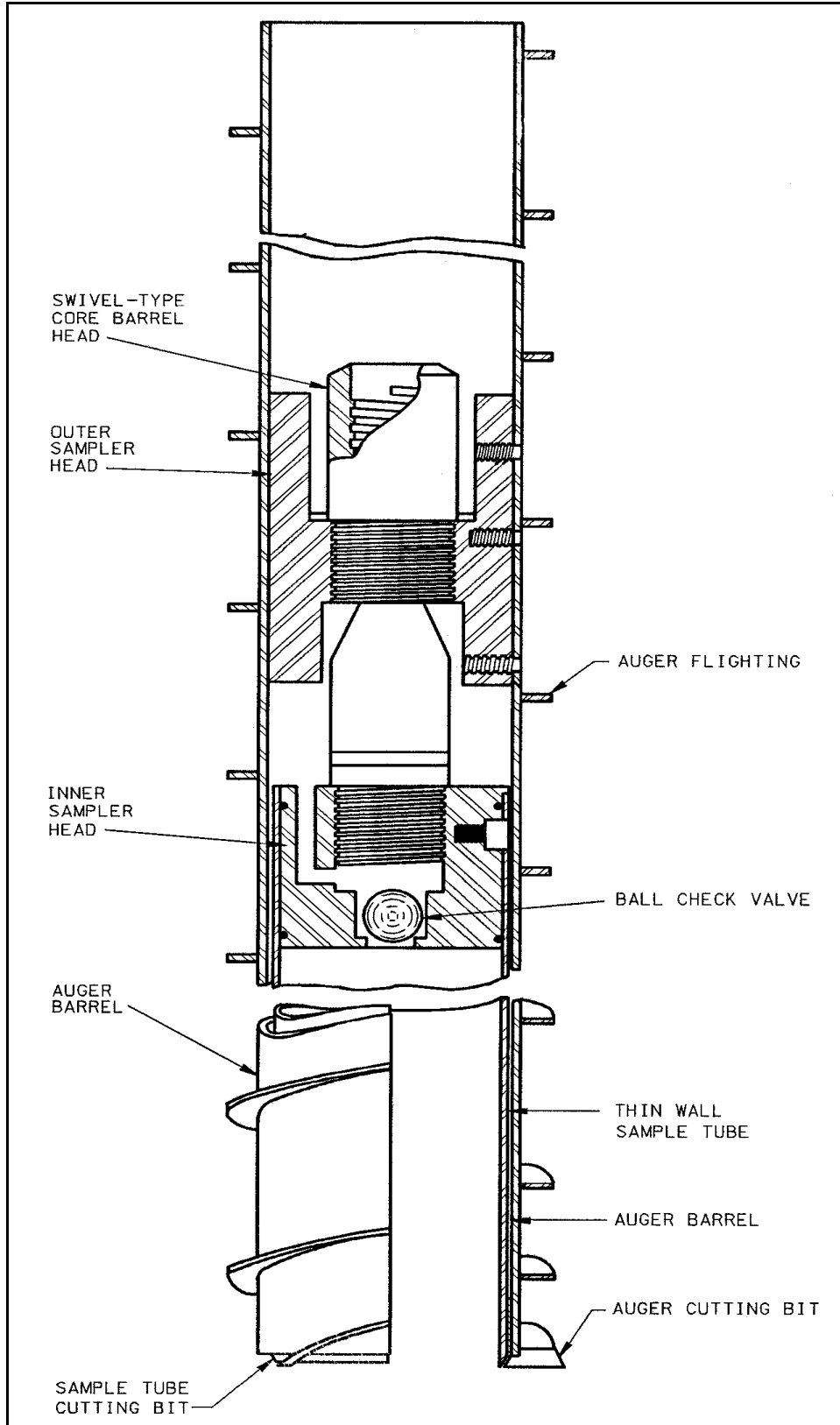

Figure 5-15. Schematic drawing of a hollow-stem auger with thin-wall sampling tube (after U.S. Department of the Interior 1974)

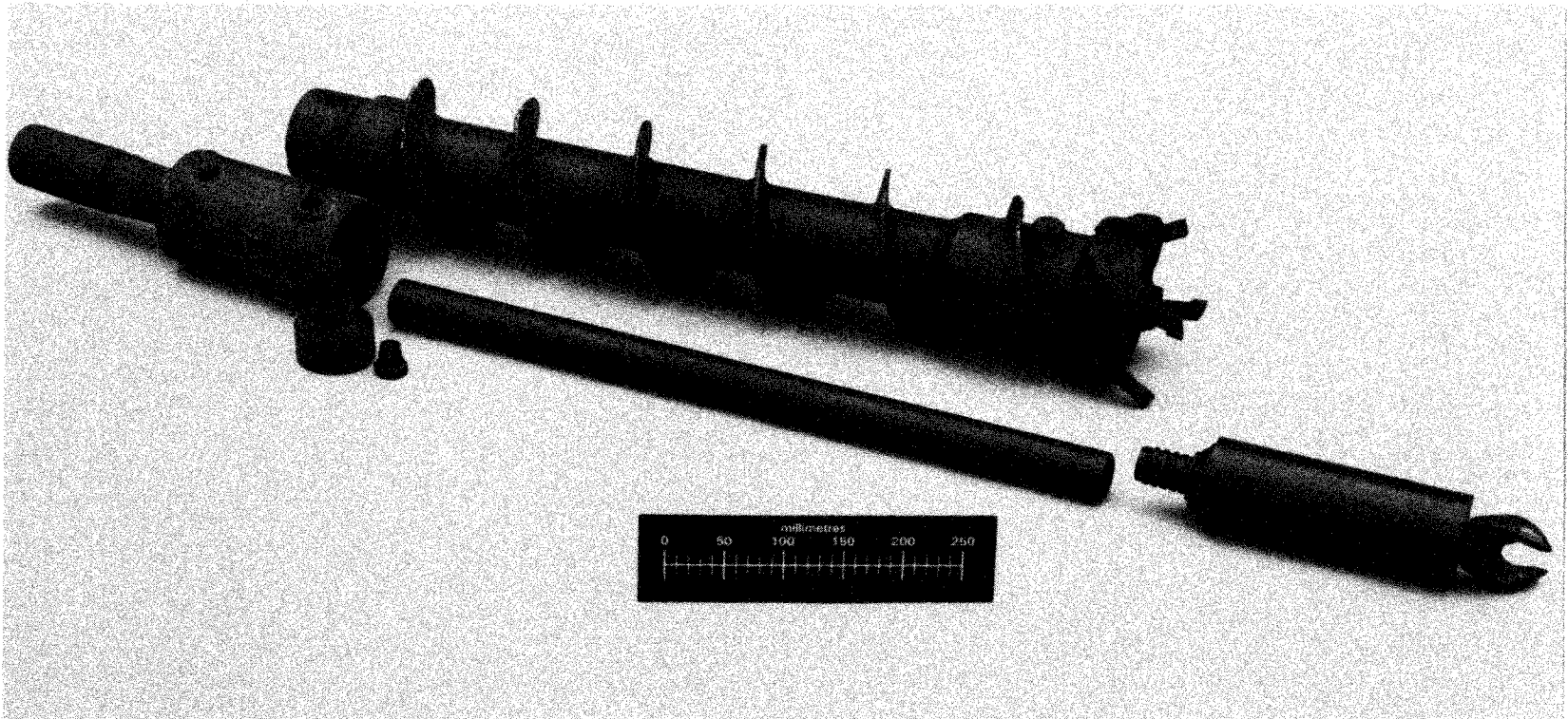

Figure 5-16. Photograph of a hollow-stem auger with a center drag bit

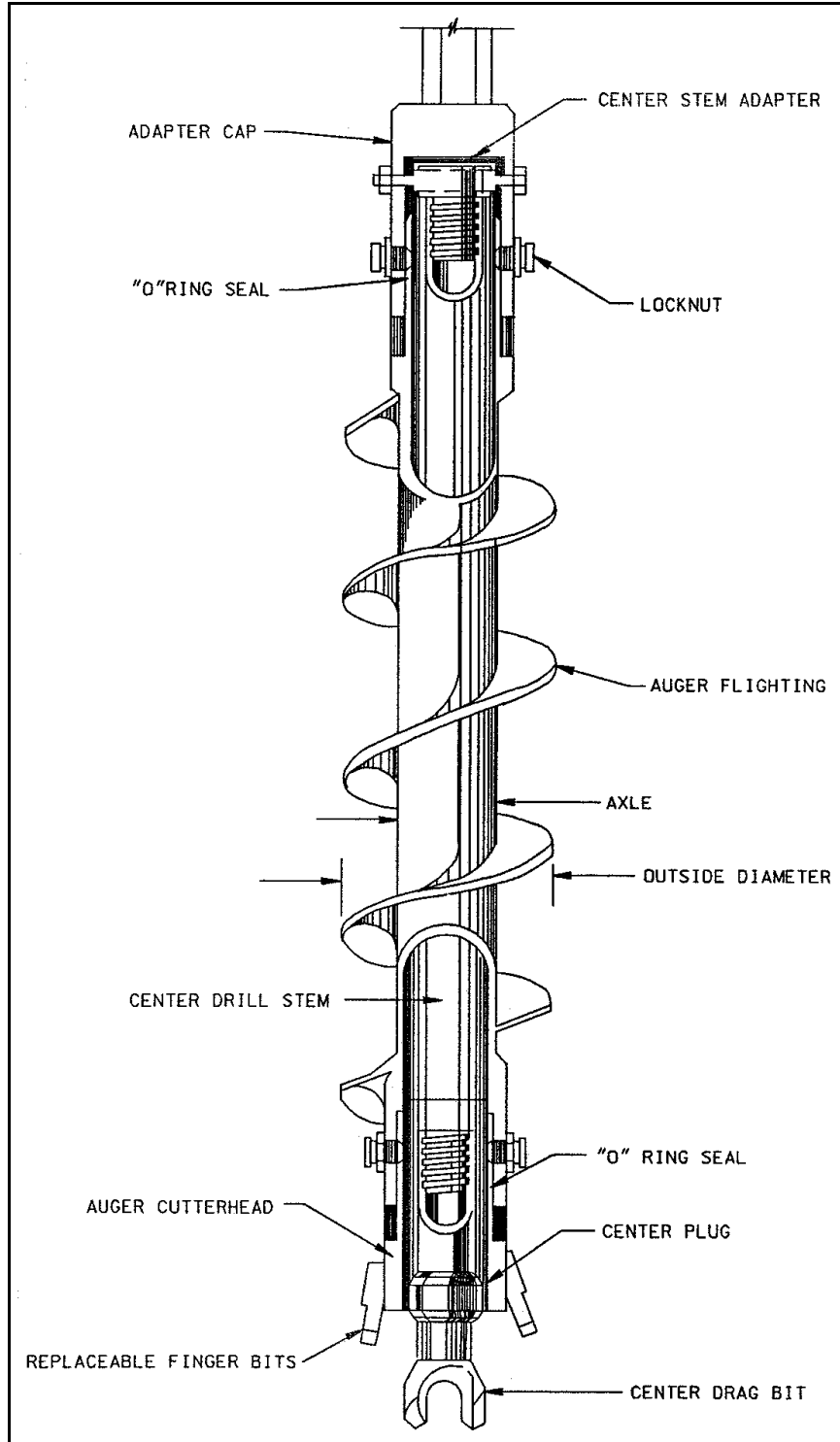

Figure 5-17. Isometric drawing of the hollow-stem auger with the center drag bit which can be used with soil sampling devices (after Acker 1974)

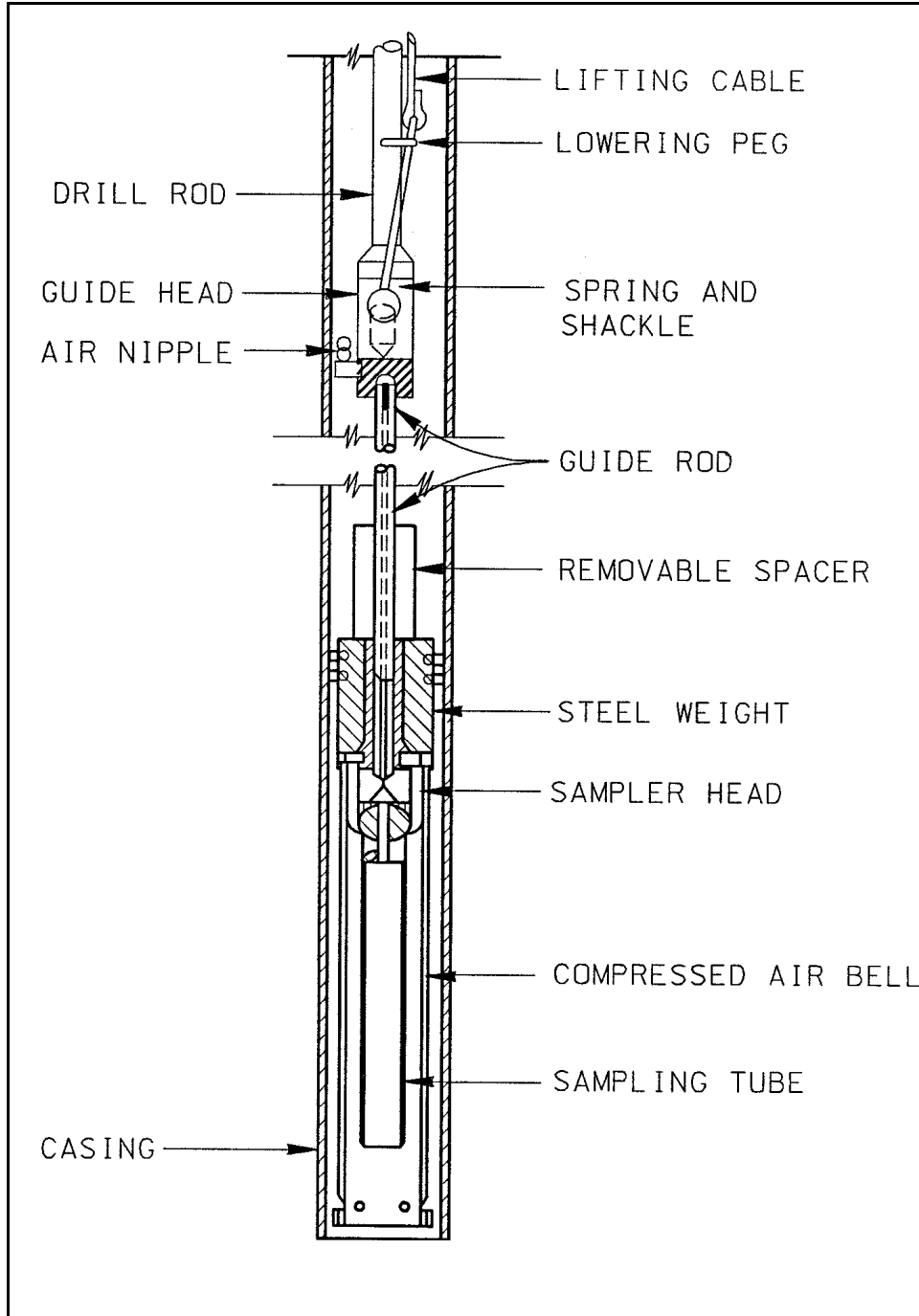

Figure 5-18. Schematic drawing of the Bishop sand sampler (after Hvorslev 1949)

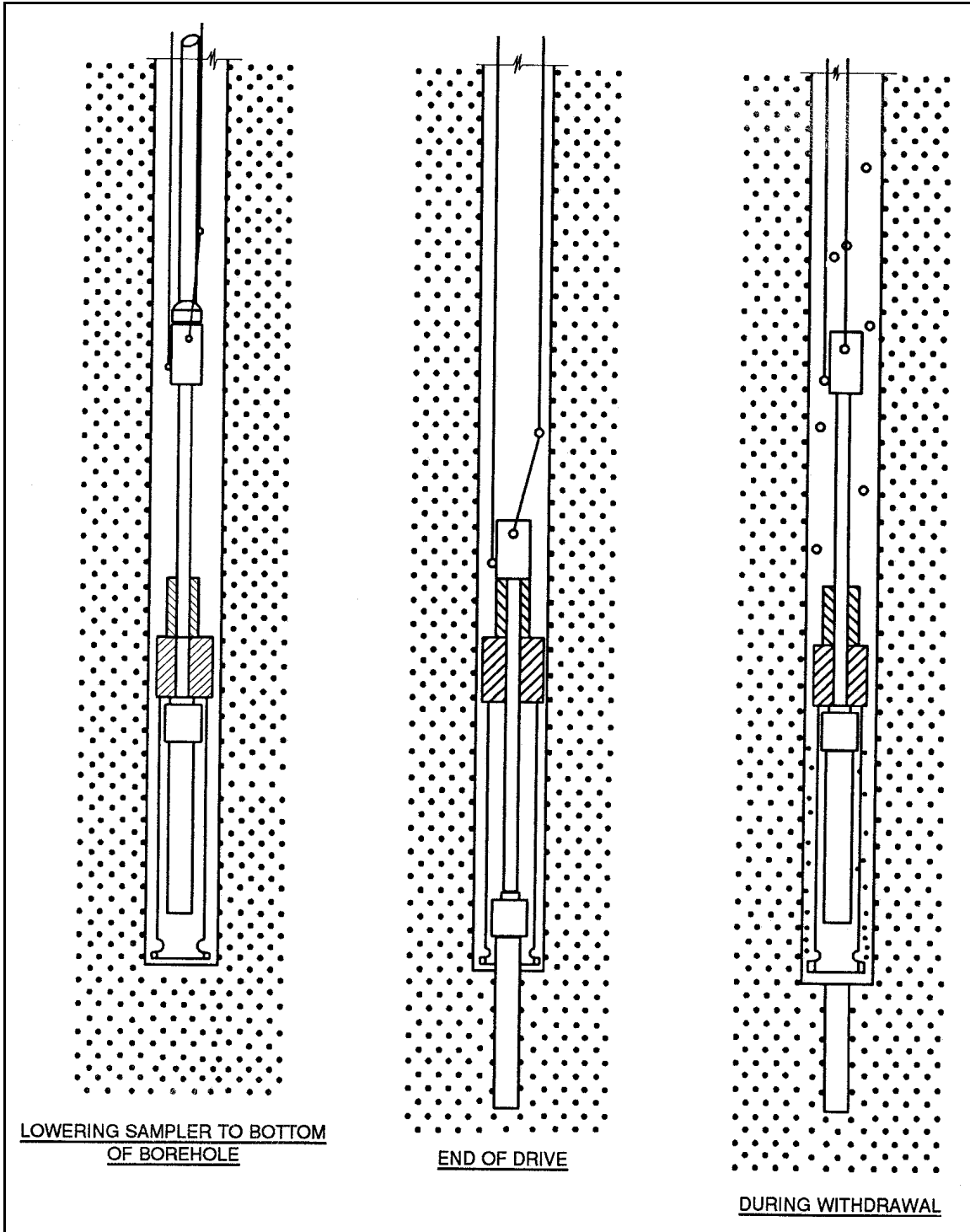

Figure 5-19. Diagram illustrating the operation of the Bishop sand sampler (after Hvorslev 1949)

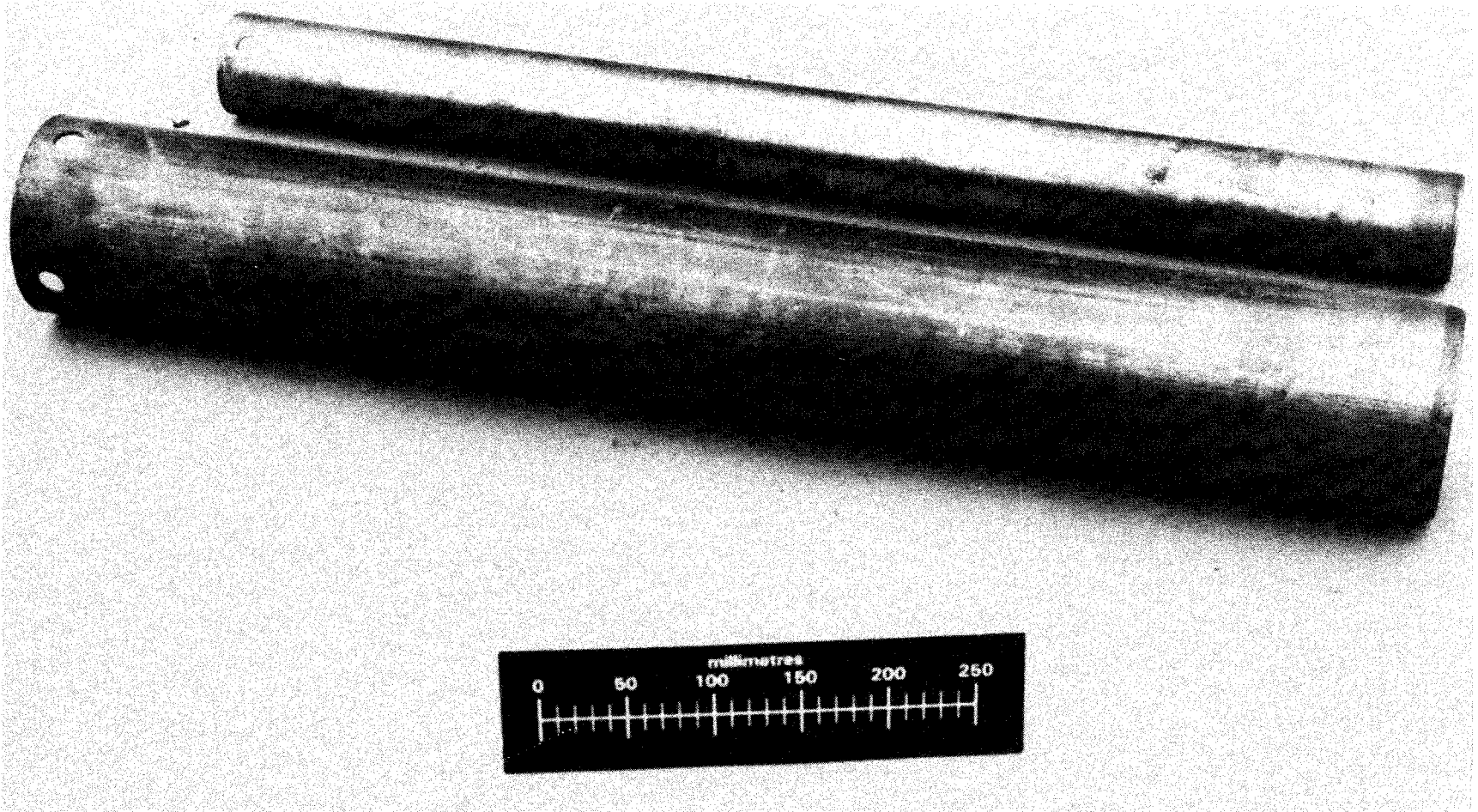

Figure 5-20. Photograph of 75-mm- (3-in.-) and 125-mm- (5-in.-) diam sampling tubes

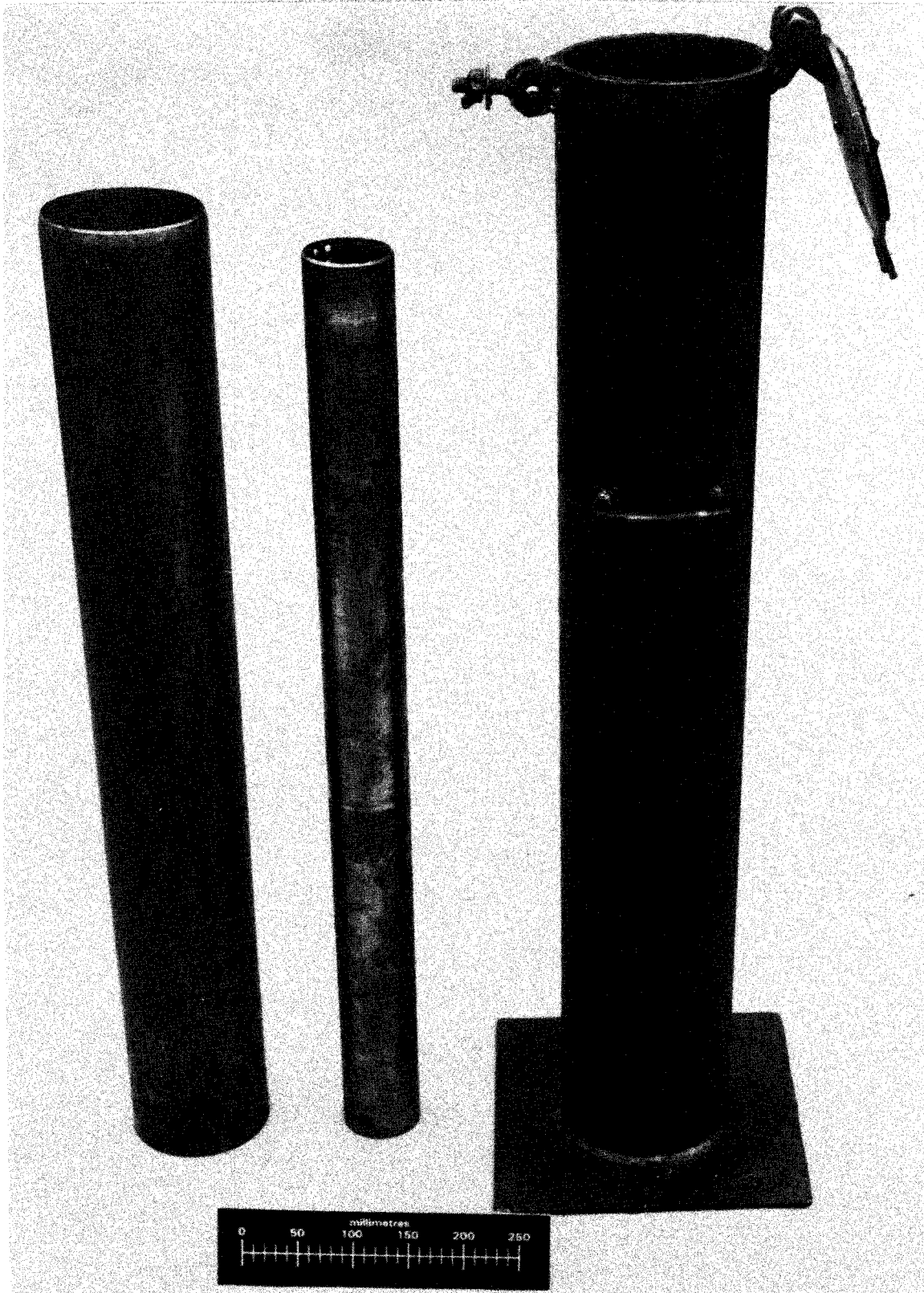

Figure 5-21. Photograph of a dipping tank for coating 75-mm- (3-in.-) and 125-mm- (5-in.-) diam sampling tubes

Chapter F-6 Procedures for Undisturbed Soil Sampling In Borings

6-1. Advancing the Borehole

Position the drill rig over the sampling location, chock the wheels on the drill rig, and adjust the mast to a vertical position. Place the drill rods and related equipment at a convenient location for use with respect to the drill rig. The drill rods, sampling equipment, casing, etc., may be placed about 5 m (15 ft) from the drill rig. Set the fluid slush pit, if used, at the drill rig. The inspector's work station, areas for sample storage, power units, support vehicles, and other equipment can be located at greater distances, depending on the type of drilling and/or sampling operations, site topography, weather conditions, logistics, etc.

After a vertical pilot hole has been established, attach the drill bit or auger to the drill rod and lower the string into the borehole. Attach more drilling rods or auger flights, as necessary. At the bottom of the borehole, the depth of the borehole is advanced to the desired depth by rotating the auger or bit and applying a downward pressure from the drill rig or by gravity feed as required to achieve a satisfactory penetration rate. After the hole has been advanced to the desired sampling depth, remove the excess cuttings from the bottom of the hole before the drill string is withdrawn. As the string is withdrawn, disconnect the sections of rod and lay aside. Repeat until the cutting head is retrieved.

When lowering the equipment into the borehole to a new sampling depth, repeat the above procedures in reverse order. Count the number of rods to determine the depth of the borehole. Carefully monitor and record the depth of the hole for use during the sampling operations. All trips up and down the borehole with the drill string should be made without rotation.

In order to obtain an undisturbed soil sample, a clean, open borehole of sufficient diameter must be drilled to the desired sample depth. The sample should be taken as soon as possible after advancing the hole to minimize swelling and/or plastic deformation of the soil to be sampled.

a. Diameter of the borehole. The diameter of the borehole should be as small as practical. If casing is not used, a borehole 6 to 19 mm (1/4 to 3/4 in.) greater in diameter than the outside diameter of the sampler should be sufficient. In soils containing irregular hard and soft pockets that cause deviation of the drill bit or in soils that tend to squeeze, a slightly larger clearance, i.e., 12 to 19 mm (1/2 to 3/4 in.), may be required. When casing is used, the hole should be drilled 6 to 25 mm (1/4 to 1 in.) larger than the OD of the casing. Paragraph 6-2*b* outlines the procedure for setting casing.

b. Methods of advance. Boreholes for undisturbed samples may be advanced by rotary drilling methods or with augers. Augers are discussed in Chapters 3, 7, and 8. If rotary drilling is used, the bit must deflect the drilling fluid away from the bottom of the hole. Displacement and percussion methods for advancing boreholes are not acceptable for undisturbed sampling operations.

(1) *Augering.* Auger borings are generally used in soils where the borehole will remain open, usually above the groundwater table. Augers operate best in somewhat loose, moderately cohesive, moist soils. Augers may also be used in medium-to-hard clays, silts, and/or sands containing sufficient fines to prevent the hole from caving. In general, the holes are bored without the addition of water, although the introduction of a small amount of water may aid in drilling in hard, dry, or cohesionless soils. Below the

groundwater table, drilling fluid or casing may be required to stabilize the borehole. Because auger borings typically do not use drilling fluid, the auger boring method may be preferred for drilling in embankment dams, thus eliminating the potential for hydraulic fracturing, and in water sensitive formations.

To advance the borehole using solid- or hollow-stem, single- or continuous-flight helical augers, the auger is attached to the spindle or kelly on a drill. The auger is lowered into the borehole, and downward pressure is applied as the auger is rotated. Sufficient pressure should be applied to cause the auger to penetrate as it cuts. However, the auger should not be forced into the soil so rapidly as to displace the soil outward or downward. A rotational velocity of 50 to 150 revolutions per minute (rpm) is suggested, although the velocity should be adjusted according to the field conditions and the judgment of the driller. In general, a slower rate of feed will result in smaller cuttings, whereas a rotational velocity greater than approximately 150 rpm will result in excessive vibration of the drill string. At a depth of about three- to four-hole diameters above the top of the intended sample, additional care should be taken to prevent disturbance by decreasing the rate of hole advance. At the desired sampling depth, rotate the auger until the cuttings are removed from the bottom of the borehole.

(a) *Short-flight augers.* The short-flight helical auger is particularly advantageous for advancing shallow holes, i.e., the bottom of the hole may be reached with the auger attached directly to the kelly. The depth of the borehole is usually limited to the length of the kelly, which is typically 3 to 6 m (10 to 20 ft). To operate, the auger is lowered to the bottom of the hole and rotated to cut and fill. When the auger flight(s) is filled, the auger is raised above the ground surface without stopping the rotation. After the auger is clear of the borehole, the kelly can be rotated rapidly to throw the soil from the auger. The centrifugal force of the auger rotation causes all but sticky soils to be thrown from the auger; a temporary increase in rotational speed may be required to spin off these soils. Repeated passes must be made in and out of the hole to advance the borehole.

Several trial runs with the auger will determine the amount of advance of the borehole required to just fill the auger. Excess penetration disturbs the soil at the bottom of the hole, whereas an overfilled auger acts as a piston. As the overfilled auger is withdrawn, the sidewalls and the bottom of the hole tend to be pulled inward and upward by suction. This disruption may cause the walls of the hole to squeeze or collapse and to disturb the soil at the bottom of the borehole.

(b) *Continuous-flight augers.* Continuous-flight augers may be used to advance the borehole in all soils except loose sands and gravels. As the auger penetrates the formation, the flights act as a screw conveyor to bring the soil to the surface. Additional sections can be attached to the cutter head to drill to increased depths. Hollow-stem augers may be used as casing to prevent the caving of certain soils; removal of the center rod and pilot bit allows a sampler to be operated through the stem of the auger.

If a solid-stem auger is used to advance the borehole, the auger flights must be removed from the borehole prior to sampling. Pull the drill rods and auger flights from the borehole without rotation. Disconnect the drill rods and auger flights and lay aside. Repeat until the last section of rods or auger flights has been brought to the surface. After the sample has been obtained, lower the auger and drill rods into the borehole using the above procedures in reverse order. Advance the borehole to the next sampling depth. Prior to sampling at the new depth, clean the borehole by rotating the auger until the cuttings are picked up by the auger (cuttings are no longer thrown from the auger flights).

(2) *Rotary drilling.* To advance a borehole using rotary drilling methods, a baffled drag-type or fishtail bit is rotated and advanced by gravity feed and/or downward pressure applied from the drill rig as

required to achieve a satisfactory penetration rate. A suitable drilling fluid, such as compressed air or a water-based bentonite mud, is pumped through the drill rods to clean and cool the bit and transport the cuttings to the surface. The bit rotation speed and the rate of advance as well as the drilling fluid consistency and circulation rate must all be adjusted to produce cuttings small enough to be transported to the surface as fast as the bit penetrates. A drilling mud consisting of a ratio of approximately 22.7 kg (50 lb) of bentonite per 375 dm³ (100 gal) of water performs satisfactorily as a drilling fluid for most conditions and usually eliminates the need for casing. Compressed air may be preferred, however, when sampling dry or water-sensitive soils, such as expansive clays or shales and soils containing gypsum. Rotary drilling equipment is discussed in Chapter 3; drilling fluids are discussed in Chapter 4.

Bottom discharge rotary bits are not acceptable for advancing the borehole for undisturbed sampling. Side discharge bits may be used with caution. Prior to sampling, the loose material from the hole must be removed as carefully as possible to avoid disturbing the material to be sampled. Jetting through an open-tube sampler to clean out the borehole to sampling depth is not permitted.

(3) *Hydraulic-piston sampler.* Advancing boreholes with an hydraulic-piston sampler requires special adaptation. The method is similar to conventional rotary drilling, except the soil is cut away by cutting teeth welded to the bottom of the sampler rather than using a drag-type or fishtail bit to advance the hole. Drilling-fluid ports are provided in the thin-walled sampling-tube head to allow fluid to pass between the sample tube and the main sampler barrel. The rate of drilling fluid circulation should be minimized to prevent jetting ahead of the bit, but sufficient to avoid blockage of the hole. After the boring has been advanced to the sampling depth, a check ball is dropped through the drill rods to close the ports and facilitate a sample push.

(4) *Displacement methods.* Displacement plugs or samplers should not be used to advance boreholes for undisturbed samples. Displacement causes disturbance below the depth of penetration to a depth in excess of three to four times the diameter of the plug or sampler.

(5) *Percussion drilling.* Percussion drilling should not be used to advance boreholes for undisturbed samples. Vibrations caused by percussion drilling creates disturbance to a depth of several borehole diameters.

6-2. Stabilizing the Borehole

Boreholes in soft or loose soils, or when the boring is extended below the groundwater level, may be stabilized with drilling mud and/or casing. Generally, drilling mud will stabilize the borehole. However, when severe cases of caving soils are encountered, casing may be required. If casing is used, it should never be driven. If it is advanced ahead of the borehole, heaving at the bottom of the hole could occur. For some soils, it is often very difficult to advance the borehole ahead of the casing because of heaving at the bottom of the hole and squeezing of the sidewalls. For these types of soils, water or drilling mud may help stabilize the hole.

a. Drilling mud. Drilling mud is normally used as the drilling fluid for most soils as it efficiently removes the cuttings from the borehole. Drilling mud is also an effective means for minimizing stress relief at the bottom of the borehole, supporting the sidewalls of the hole to prevent caving, and holding the sample in the sampler as it is withdrawn from the boring. Information regarding the use of drilling mud to stabilize the borehole is presented in Chapter 4.

b. Casing. Casing is normally used to stabilize boreholes only when a particular stratum or casing zone is encountered and must be sealed or when drilling mud would have an adverse effect on the soil to be sampled, such as a dry or water-sensitive formation. Flush-joint or flush-coupled casing is the most satisfactory type of casing. The flush internal surface of this type of casing prevents hanging and jarring of the sampler. Similarly, the flush external surface of the casing minimizes the annular space required between the casing and the walls of borehole and thus ensures a more stable hole. The flush external surface also reduces the resistance for installation and removal of the casing from the hole. When sloughing or crumbly surface material is encountered, a short section of casing may be required, especially when operations extend for several days. Additional information on casing is presented in paragraphs 3-4*d* and 8-1*b*.

When casing is used, the hole should be drilled or reamed to a diameter 6 to 25 mm (1/4 to 1 in.) larger than the OD of the casing to within a few feet of the stratum to be sampled. The casing should then be inserted in the borehole and pushed or jacked to a depth to effect a seal in the soil at the bottom of the casing. The casing should not be pushed into the stratum to be sampled as disturbance could result. Likewise, the casing should not be driven, as many soils are sensitive to the vibrations caused by driving. As a reminder, each joint should be securely tightened as the casing is assembled. Securely tightened joints help to ensure that threads will not be damaged as the casing is advanced. Furthermore, a joint that is securely tightened prior to placement is also much easier to disassemble as it is removed.

After the casing has been seated at the desired depth, the hole must be cleaned before the undisturbed sample can be taken. A noncoring bit such as a drag bit should be used. After the drill string has been lowered into the borehole and circulation of the drilling fluid has begun, the drill string and bit should be rotated and fed downward with a moderate pressure.

As the depth of the hole is increased, the casing may be advanced by rotation and/or jacking to a depth just above the top of the next undisturbed sample. If the casing is advanced by rotation, a casing shoe with teeth set outward may be required to cut a hole with sufficient clearance to advance the casing.

6-3. Cleaning the Hole Before Sampling

A clean open borehole with a minimum of disturbed material at the bottom is essential to obtaining satisfactory undisturbed soil samples. A careful, experienced operator can detect excess material in the bottom of the hole by the actions of the tools and should repeat and/or continue the cleaning operations until the hole is clean. After the borehole has been thoroughly cleaned, the depth to the bottom of the hole should be obtained and recorded. This measurement can be compared to the depth of the hole when the sampler or other device is lowered; if discrepancies exist, cuttings suspended in the drilling fluid or slough from the wall of the borehole may have settled to the bottom of the hole.

a. Cleaning with augers. In boreholes advanced with an auger, the auger is used to clean the hole. After the hole has been advanced to the desired sampling depth and the cuttings have been removed from the auger, the auger should again be lowered to the bottom of the hole and turned several revolutions without advancing the hole to pick up any loose material. The auger must then be carefully withdrawn without rotation to prevent any loss of material from the auger flights or dislodging of material from the sidewalls of the hole.

b. Cleaning with rotary drilling methods. In boreholes advanced by rotary drilling methods, the bit rotation and drilling fluid pumping rate should be reduced as the bit reaches a depth to within 0.3 m (1 ft) of the desired sampling depth. The bit should then be advanced slowly to the desired depth of the

top of the undisturbed sample. Circulation of the drilling fluid should be continued at the reduced pumping rate until the cuttings in the drilling fluid near the bottom of the boring are washed out. The boring is properly cleaned when the concentration of fine particles per unit volume of suspension becomes constant.

6-4. Sampling Procedures

Procedures for obtaining undisturbed samples using open- and piston-type thin-walled push-tube samplers and core barrel samplers are discussed in the following paragraphs. Details of the equipment are presented in Chapter 5.

a. Push samplers. After the borehole has been advanced and cleaned, the assembled sampler is lowered to the bottom of the borehole. Care must be used to prevent dislodging of materials from the sidewalls of the borehole. With the bottom of the sampler just in contact with the soil to be sampled, the drill rods are chucked in the drill rig. This prevents the weight of the drill rods and sampler from bearing upon and possibly disturbing the material to be sampled. To sample, a thin-walled cylindrical tube is forced into the undisturbed soil in one continuous push without rotation.

Thin-walled sampling tubes may be used in very soft to stiff clays, silts, and sands that do not contain appreciable amounts of gravel. Most samplers are about 60 to 75 cm (24 to 30 in.) long, although the length of the sampling drive is limited by the capability of the drilling rig for a continuous smooth push, the type of sampler which is used, and the material to be sampled. Generally, 125-mm- (5-in.-) diam sampling tubes should be used in clays and silts which can be removed from the tube and preserved in an undisturbed state in a wax-coated cardboard tube. Samples of very soft clays and silts which will not support their own weight and cannot be extruded in an undisturbed state should be taken with either 75- or 125-mm- (3- or 5-in.-) diam sample tubes and sealed in the tube with expanding packers or wax. A 75-mm- (3-in.-) diam sample of clean sand is usually satisfactory. High penetration resistances may preclude pushing larger sampling tubes in cohesionless soils, especially in dense sands.

(1) *Methods of advance.* The methods for advancing thin-walled samplers include drill-rig drive, hydraulic-piston sampling, and pushing by hand. These methods and their limitations are discussed in the following paragraphs.

(a) *Drill-rig drive.* One technique of pushing a thin-walled sampler is using the hydraulic drive mechanism on the drill rig. The sampling tube is advanced in one uniform, continuous push without rotation by applying a downward force through the drill rods. If the push is interrupted, it should not be resumed for any reason as adhesion and friction quickly develop between the sample and sampling tube during the interruption. Restarting the push will result in increased penetration resistance and additional disturbance to the sample. Prior to the sampling drive, the rig should be firmly anchored to prevent the reaction of the drive from raising the rig during the push. Screw-type earth anchors (Figure 6-1) are typically installed to a depth of about 1-1/2 m (5 ft). Screw-type earth anchors can be fastened to the drill rig with load binders, as shown in Figure 6-2, to provide adequate anchorage to the rig.

(b) *Hydraulic-piston sampling.* The hydraulically actuated piston sampler uses a variation of the drill-rig drive method of advance which was discussed in the preceding paragraph. The drill rods are chucked and hydraulic pressure is applied downhole through the drill rods to the sampler head. An increase of pressure in the sampler head causes the thin-walled tube to be advanced into the undisturbed soil at the bottom of the hole. The rods and drill rig provide the reaction force for advancing the sampling tube. The hydraulic-piston sampling method of advance cannot be used satisfactorily in hard

clays and silts, dense sands, or gravelly soils, as the penetration resistance may cause the rods to buckle. If the drill rods buckle, the sample may be seriously disturbed.

(c) *Pushing by hand.* Usually, an undisturbed sampler is pushed by hand only in test pit sampling where short, small-diameter, thin-walled samplers are used. The sample quality may be enhanced by the advance trimming and pushing technique and the use of tripod frame for guiding the sampling tube. See Chapter 11 for details.

(d) *Mechanical or hydraulic jacking.* Hand-operated mechanical or hydraulic jacks used in field operations produce an erratic, slow rate of penetration and cause vibrations in the drill rod string. As a result, the jacking method should be avoided because of the disturbance to the sample.

(2) *Rate of penetration.* The rate of penetration of a thin-walled undisturbed sampler greatly affects the degree of disturbance to the sample. A fast, continuous penetration of the sampling tube is required to prevent the buildup of friction between the sampling tube and the soil. The rate of penetration should be as constant as possible throughout the drive. Penetration rates on the order of 5 to 30 cm/sec (2 to 12 in./sec) are recommended.

(3) *Sampler withdrawal.* After the sampling drive has been completed, the withdrawal of the sampler should be delayed briefly to increase adhesion and/or friction between the soil and the sampling tube which will assist in holding the sample in the tube. Usually, the time which is required to measure the length of the push and other minor operations following the push is sufficient. The sampler should be withdrawn slowly and uniformly with a minimum of shock and vibration. A fast withdrawal tends to create a vacuum below the sampling tube which may cause a loss of the sample. If drilling fluid is used in the borehole, fluid should be added as the sampler is removed to keep the borehole full all times.

(4) *Open-tube samplers.* Open-tube samplers are perhaps the simplest tool to obtain samples. However, because of the simplicity of the design and operation of the sampler, a lower quality of sample frequently results. A discussion of the procedures for obtaining undisturbed samples with the open-tube thin-walled sampling tube follows.

After the sampler head has been inspected to make sure that the ball check valve is clean, free moving, and functioning properly, attach a sampling tube to the sampler head. One end of the tube should be sharpened to form a cutting edge and should have an inside clearance ratio suitable for the soil being sampled (see paragraph 2-3). Lower the sampler and the drill rod assembly to the bottom of a clean borehole and clamp in the jaws of the chuck on the drill rig. The depth to the bottom of the hole should be recorded.

Establish a reference point and mark the desired length of push on the drill rod. The length of the push should be a few centimeters shorter than the length of the sampling tube to ensure that the sample is not compressed in the tube. When advancing the sampler, note the maximum hydraulic feed pressure or any variation in pressure which would indicate soft, firm, or gravelly zones. After the sampler has been advanced the desired length of drive, rotate the sampler at least two revolutions to shear the soil at the bottom of the tube. Withdraw the sampler from the borehole as carefully as possible to minimize disturbance of the sample.

After the sampler has been removed from the borehole, remove the sampling tube from the sampler head and measure the recovered length of sample. Compare the recovered sample length to the length of the push. Record these data.

Trim about 5 cm (2 in.) of material from the bottom of the sample. Place the trimmings in a jar for use as a water content specimen and for visual classification. Measure the distance from the bottom of the push tube to the bottom of the trimmed sample. Record these data. Insert an expandable packer in the bottom end of the push tube if the sample is to be shipped to the laboratory. If the material is to be extruded on site, the installation of the packers is omitted.

Trim all loose, disturbed material from the top end of the tube. If possible, trim an additional 5 cm (2 in.) into the undisturbed sample; these trimmings can be used to determine the water content and to conduct a visual classification of the material, as suggested in the preceding subparagraph. Measure and record the distance from the top of the tube to the top of the trimmed sample. Insert an expandable packer in the top end of the tube unless the sample is to be extruded on site. Determine the trimmed sample length by summing the lengths to the top and the bottom of the trimmed sample; subtract this sum from the total length of the tube. Record the data.

The trimmings from the bottom (and top) of the sampling tube should be sealed in a glass jar(s) for retention and use at the soils laboratory. The jars should be sealed immediately to keep the soil from drying. Care should be exercised to prevent the soil from becoming contaminated with drilling fluid or other contaminants which could affect the in situ water content or soil classification. A few grams of soil from the trimmings may be used to visually classify the soil according to the procedures listed in Appendix E. A visual description and classification of the soil should be entered in the boring logs (see Chapter 13).

(5) *Piston samplers.* Piston samplers, such as the Hvorslev and the Osterberg samplers, are used for obtaining soil samples above or below the groundwater table, including cohesionless sands and soft, wet soils that cannot be sampled using the thin-walled open-tube sampler. The principal functions of the piston include preventing cuttings, shavings, or slough material from entering the tube as it is lowered to the bottom of the borehole and increasing sample recovery. A discussion of the procedures for sampling with fixed-piston samplers is presented in the following paragraphs.

(a) *Hvorslev fixed-piston sampler.* The Hvorslev fixed-piston sampler is a mechanically activated sampler which contains many precision parts and screw connections. The specific assembly and operation procedures must be performed in the proper sequence to ensure proper operation of the sampler. Before attempting to use this apparatus, the operator should thoroughly understand the mechanics of the sampler because the precision parts could be easily damaged by misuse or incorrect assembly. Consequently, it is suggested that this sampler be used only by or under the direction of an experienced operator.

To operate, the sampler should be assembled with the piston locked flush with the bottom of the sampling tube. Attach drill rods and piston rod extensions, as necessary, and lower the sampler to the bottom of a clean hole. When the sampler is in contact with the bottom of the hole, clamp the drill rods in the drill-rig chuck assembly. It should be noted that the Hvorslev sampler is not prone to cutting into the side of the hole as it is lowered because the piston is locked at the bottom of the sampling tube. Furthermore, the sampler can be placed firmly against the bottom of the hole without picking up cuttings because the piston is locked in position. However, care is required to ensure that the weight of the drill string does not cause the sampler to penetrate or compress the undisturbed soil at the bottom of the hole.

An alternative method of operating the sampler consists of attaching drill rods only, prior to lowering the device to the bottom of the borehole. When the sampler has been placed on the bottom of the hole, lower the piston rods through the drill rods and attach the rods to the top of the sampler. The coarse female

thread end on the piston rod should be placed downhole first. When a sufficient length of piston rods have been added to the string to contact the piston rod extension which is located at the top of the sampler, screw the piston rods in a clockwise direction onto the piston rod extension. After the piston rods have been connected to the piston rod extension, continue the clockwise rotation of the piston rods for seven revolutions to unlock the piston.

Prior to sampling, secure the piston rods to the drill-rig mast or to a frame which is independent of the drill rig. Place a reference mark (use grip pliers) on the piston rod at the top of the drill rods. Advance (push) the sampler into the undisturbed soil using the drill-rig drive in the same manner as described for the thin-walled open-tube sampler. The sampler should be advanced into the undisturbed soil at a uniform, continuous rate without exceeding 75 cm (30 in.). The push should be stopped if the drill rig is lifted off the ground, as the sample could be disturbed or the sampler could be damaged. After the sampler is advanced, clamp a vise grip pliers on the piston rod at the top of the drill rod string to prevent the piston rod from sliding down. Measure and record the distance between the original reference mark and the top of the drill rods. This distance is the push length.

At the end of the drive, rotate the drill rods clockwise two rotations to shear the sample at the bottom of the sampling tube and to lock the piston. Retract the sampler into open borehole. Disconnect the piston rods from the sampler by continued rotation of the drill rods in the clockwise direction; this action allows the piston rods to be removed before the sampler is withdrawn. Remove the sampler from the borehole. During the withdrawal of the sampler from the borehole, the piston is held stationary at the top of its stroke by a split cone clamp. Extreme care must be exercised when the sampler is removed from the borehole to avoid jarring or losing the sample.

Remove the sample tube from the sampler after the vacuum breaker rod is removed. Make necessary measurements to the nearest 0.5 cm (0.01 ft), including sample lengths and any gap that may exist between the piston and the top of the sample. Record the data, seal the sample for shipment to the soils laboratory, identify and label the sample, and update the boring logs (see Chapter 13). Generally, the undisturbed soil sample will be sealed and shipped to the laboratory in the sample tube, unless the sample is extruded on site. After each sampling drive has been completed, the sampler should be disassembled and thoroughly washed, cleaned, lubricated, and reassembled before the next sampling drive.

(b) *Butters fixed-piston sampler.* The Butters sampler is a mechanically activated Hvorslev-type fixed-piston sampler. The basic operation of the Butters sampler is similar to the operation of the Hvorslev sampler. The basic differences are the Butters sampler has all right-hand threads and a simplified piston rod locking and unlocking mechanism; these features make the Butters sampler much easier to operate.

Because of the similarity of the Hvorslev and Butters samplers, details for operation of the Butters sampler are not presented herein. As is the case for any sampler, the mechanics of the Butters sampler must be thoroughly understood by the operator before it is used because the precision parts could be easily damaged by misuse or incorrect assembly. Therefore, it is suggested that the sampler be used only by or under the direction of an experienced operator.

(c) *Osterberg fixed-piston sampler.* The Osterberg sampler is a hydraulically activated fixed-piston sampler which is significantly different in design and operation from the mechanically activated Hvorslev and Butters samplers. Since the Osterberg sampler does not require piston rod extensions, it is faster and easier to assemble, operate, and disassemble than the mechanically-activated samplers. However, the sampler does contain moving parts with O-ring seals which require careful assembly and

must be kept clean and lubricated for proper operation. Therefore, it is recommended that clear water should be used to advance the sampler because the sand particles suspended in the drilling mud are abrasive and can damage the O-ring seals; however, this recommendation may not always be feasible.

The sampler should be assembled with the piston flush with the bottom of the sampling tube and lowered to the bottom of a cleaned hole. Because the piston is fixed in position, the sampler can be placed firmly against the bottom of the hole. The drill rods should be securely attached to the drill rig to provide a reactionary force for pushing the sampling tube into the undisturbed soil.

To advance the sampler, fluid pressure is applied through the drill rods to the sampler pressure cylinder. Due to the pressure increase, the inner sampler head is forced downward to advance the sample tube into the undisturbed soil. When the inner sampler head has reached its full stroke (the sampling tube has penetrated its full depth into the soil), the pressure is relieved through bypass ports in the hollow piston rod. The change of pressure can be observed as a drop in the reading on a fluid pressure gauge. An air bubble and/or drilling fluid return observed at the top of the mud column indicates that the sampler has been advanced its full distance. The fluid pump should then be disengaged.

The sampling tube cannot be overpushed because the fluid pressure is automatically relieved by circulation bypass through ports in the hollow piston rod once the sample tube has advanced its full length. However, if the fluid pressure does not decrease and a return flow is not observed, this fact usually indicates that a full stroke or drive was not achieved. If a full drive cannot be completed, it is necessary to measure the actual drive once the sampler has been lifted out of the hole. This measurement should be noted on the boring logs.

After the drive has been completed, the sampler should be rotated two or three revolutions in a clockwise direction to lock the sample tube in position for withdrawal from the hole. The rotation of the sampler activates a friction clutch mechanism that allows the inner sampler head to grasp the inside of the sampler pressure cylinder. This action also shears the sample at the bottom of the sampling tube.

The sampler should be withdrawn slowly and very carefully from the borehole to avoid jarring or losing the sample. After the sampler has been withdrawn from the borehole, the sampling tube should be removed from the sampler. After the bolts or screws which are used to attach the sampling tube to the sampler head have been removed, the vacuum which was developed as a result of the sampling drive must be released before the tube can be removed from the head. The vacuum can be released by drilling a small hole through the tube just below the piston. Once the vacuum has been released, the sample tube can be removed from the sampler. Necessary data should be recorded, the sample should be sealed and identified, and the boring logs should be updated (see Chapter 13). The sampler should be disassembled, washed, cleaned, lubricated, and reassembled for the next sampling drive.

(d) *Modified Osterberg fixed-piston sampler.* The modified Osterberg fixed-piston sampler, like the Osterberg sampler, is a hydraulically activated fixed-piston sampler. It uses the same basic design and principles of operation as the conventional Osterberg sampler. All of the general procedures described for the Osterberg sampler also apply to the modified Osterberg sampler.

The major differences and improvements in the modified Osterberg sampler as compared to the conventional Osterberg sampler include a more rigid sampler which increases its applicability for sampling soils containing fine gravels, the use of aluminum sample liners with a case-hardened replaceable driving shoe, and the addition of a vent hole in the thick-walled inner sampler barrel to allow the vacuum seal to be broken for removal of the liner. During sampling operations, the undisturbed

sample can be easily removed from the sampler by simply removing the driving shoe and pulling the aluminum liner out of the inner sampler barrel. Reloading of the sampler is accomplished by sliding a new liner into the inner barrel, attaching the driving shoe, and pushing the inner barrel into the pressure cylinder. Because of the similarity of the Osterberg and the modified Osterberg samplers, details for operation of the modified Osterberg sampler are not presented herein. As is the case for any sampler, however, the mechanics of the modified Osterberg sampler must be thoroughly understood by the operator before it is used, as the parts could be easily damaged by misuse or incorrect assembly. It is suggested that the sampler be used only by or under the direction of an experienced operator.

b. Core barrel samplers. When the material to be sampled contains gravel or is too hard to penetrate with the thin-walled push-tube sampler, double- or triple-tube core barrel samplers such as the Denison sampler or the Pitcher sampler which are described in Chapter 5 may be used. To sample, the core barrel is lowered to within a few tenths of a foot from the bottom of the borehole and circulation of the drilling fluid is begun; the circulation helps to remove cuttings that may have settled to the bottom. The core barrel is then lowered to the bottom of the hole, rotated, and forced downward at a uniform rate. The bit pressure, speed of rotation, and drilling fluid pressure must often be determined experimentally because of the variety of core barrels, drilling fluids, and variations of the soil formations which are encountered.

The speed of rotation and the rate of advance must be adjusted to ensure continuous penetration by steady cutting of the bit. The rate of penetration should not be greater than the speed at which the outer barrel is able to cut. If the bit is advanced too rapidly, it may become plugged and grind away on the core. If the bit is advanced too slowly, or intermittently, the core will be exposed to excessive erosion and torsional stresses. The rotational speed of the bit should be limited to that which will not tear or break the soil sample. Generally, 50 to 150 rpm is satisfactory for coring most soils. The Denison sampler is advanced at a speed which allows the sample to move into the sampler without disturbance. Sampler rotation, fluid pressure, downward force, and sampler configuration should vary with the type of soil being sampled.

The drilling fluid pump pressures and flow rates should be the minimum necessary to circulate the fluid freely, carry the cuttings from the hole, and stabilize the borehole walls. Too much drilling fluid pressure and too high of flow rate will erode the core, whereas too little drilling fluid pressure and too low of flow rate will plug the bit and may allow the cuttings to enter the core barrel with the core or plug the annulus between the inner and outer barrels.

Extension of the inner barrel cutting shoe beyond the outer barrel cutting teeth depends upon the soil type. The length of the extension should be the least amount which will result in a full sample that is not undercut or contaminated by drilling fluid. If the soil formation is easily eroded, the cutting shoe should be extended below the cutting teeth of the outer barrel. If the cutting shoe will not penetrate the soil, the cutting edge must be adjusted even with or slightly above the cutting teeth of the bit.

The total length of the sampling drive should always be a few inches short of the length of the sampler to ensure that the sample is not compacted in the sampler. A sampling drive of 50 cm (20 in.) plus the length of the cutting shoe is a reasonable value for the total length of drive. A core catcher should not be used unless absolutely necessary to retain the soil. If a core catcher has been used, it should be noted on the data form. After the sampling drive has been completed, the core barrel sampler should be carefully withdrawn from the borehole to avoid disturbing the sample. The drilling practices, which are suggested in paragraph 4-7, should always be followed.

c. *Hollow-stem auger sampler.* The hollow-stem auger sampler consists of a rotating outer auger barrel with cutting bits at its bottom and a stationary inner barrel with a smooth cutting shoe. The principle of operation is similar to the operation of the core barrel sampler; the inner barrel remains stationary and slides over the sample in advance of the rotating outer barrel. The outer barrel enlarges the hole above the sample. Cuttings are lifted to the surface by the auger flights on the outer barrel, which also acts as casing in the borehole. Additional sections of auger can be added as the borehole is advanced.

The auger is rotated and forced downward in one continuous motion. Proper rotation speed and downfeed pressure are required to advance the auger sampler and to clean the borehole. Excessive downfeed pressure could cause the auger to corkscrew into the ground and bind in the hole. A center pilot bit or center auger, which can be removed at any depth and replaced with the inner barrel assembly for sampling, can be used to keep the hollow stem open. If the hollow-stem auger is used as casing below the groundwater level, the center pilot bit and auger sections should be fitted with O-rings to prevent leakage. However, if the center pilot bit must be removed for any reason, the hydrostatic pressure inside the hollow-stem auger should be adjusted to the hydrostatic pressure outside the auger barrel to prevent heaving at the bottom of the barrel as the center bit is removed.

6-5. Preservation of Samples

Undisturbed samples must be handled and preserved in a manner to preserve stratification or structure, water content, and in situ stresses, to the extent possible. Once the sample has been removed from the borehole, it must be either sealed within the sampling tube or extruded and sealed within another suitable container prior to shipment to the laboratory for testing. In general, carbon steel tubes should not be used if the samples are to be stored in the tubes for an extended period of time because the tubes will rust or corrode and may contaminate the sample. If extended storage is required, containers made of alternative metals or wax-coated cardboard tubes should be considered. Samples for water content determination must be sealed to prevent changes of soil moisture. If glass jars are used, the gasket and the sealing edge of the container must be clean to ensure a good seal. Guidance for preservation and shipment of samples is given in Chapter 13 and in ASTM Standard D 4220-83 (ASTM 1993).

a. *Storing samples in sampling tubes.* About 5 cm (2 in.) of material must be removed from the bottom of the sampling tube to provide a space for an expandable packer, as shown in Figure 6-3, or similar device, such as prewaxed circular wooden blocks, for sealing the tube. The expandable packer consists of two metal or plastic disks which are separated by a thick rubber O-ring. Tightening the wing nut which is used to hold the disks together will squeeze and force the rubber O-ring against the wall of the sampling tube to provide a moisture-proof seal. The cup cleanout auger in Figure 6-4 can be used to remove material from the bottom of the sampling tube. It produces a plane surface on which the packer may rest. The soil which is extracted from the bottom of the sampling tube should be placed and sealed in a jar or other suitable container so that it may be used later for classification and/or water content determination.

(1) *Cohesionless soils.* Immediately after the sampler has been withdrawn from the borehole, a perforated, expandable packer, similar to the one shown in Figure 6-5, must be inserted in the bottom of the sampling tube. A sheet of filter paper or paper towel should be placed between the packer and the sample. The paper will allow excess moisture to drain from the sample without losing the cohesionless material. Drainage of water from the sample will help to prevent liquefaction and minimize the sample disturbance caused by sample handling.

After the packer has been inserted in the bottom of the tube, the tube and the sampler should be carefully removed from the drill rods as a unit and kept in an upright orientation. The lower end of the tube should be placed on a firm cushioned base, and the sampler head and piston removed from the tube. Cuttings at the top of the sample tube should be noted, measured, and removed with a cup cleanout auger; free water can be removed with a suction bulb before a perforated expandable packer and filter paper or paper towel are placed against the top of the sample.

After the tube has been sealed, it should be placed in a vertical rack to allow the free water to drain. The time required for proper drainage depends on the fines fraction of the soil. Twenty-four to forty-eight hours (hr) is usually acceptable for most soil types. Under no circumstances should the sample be permitted to dry completely, as it is impossible to trim or slice a sample of dry sand or to remove it in increments for density determinations.

Throughout the preceding operations, the sampling tube should be maintained in a vertical position from the time the sample is obtained until drainage is complete. Extreme care must be exercised to avoid disturbance of the sample by rough handling or jarring. After the sample has drained, it is ready for removal from the sampling tube for field testing or for preparation for shipment to the laboratory.

Cohesionless sands may be frozen in the sampling tube and kept in a frozen state until they are tested in the laboratory. Prior to freezing, the samples should be thoroughly drained to prevent disruption of the soil structure due to the expansion of water upon freezing. Judgment should be exercised when freezing cohesionless samples containing fines or silt or clay lenses. Not only do the silt and clay lenses expand upon freezing, the lenses also impede drainage. The water in improperly drained zones will expand upon freezing and disturb or destroy the soil structure.

(2) *Cohesive soils.* Undisturbed samples of cohesive soils are usually removed from the tube soon after the sample is obtained. However, if the sample is to be preserved in the thin-walled sampling tube, a small amount of soil should be removed from the bottom of the tube and placed in a suitable container. Cuttings at the top of the sample tube should be noted, measured, and removed with a cup cleanout auger; drilling mud can be removed with a suction bulb. The sample tube should then be sealed with a solid, expandable O-ring packer or some other suitable method, as described previously.

b. Removing samples from sampling tubes.

(1) *Cohesionless soils.* Measurements to determine in situ densities can be made in the field by removing the soil from the tubes in increments and determining the volume and weight of the soil for each increment. The cup cleanout auger can be used for removing the soil. With the sampling tube oriented in a vertical direction, the cup cleanout auger is inserted in the tube to the top of the soil and rotated in a clockwise direction with a slight downward pressure. After a small amount of soil has entered the auger, the soil will bridge over and stop the cutting action of the auger. The auger should not be forced further but should be withdrawn and the soil should be removed. The process should be repeated until the desired increment of the sample has been removed. A small amount of soil may adhere to the sidewalls of the sampling tube. It should be removed and included with the soil increment. The sampling tube wall scraper, as shown in Figure 6-6, consists of a beveled plate attached to a rod.

(2) *Cohesive soils.* Undisturbed samples of cohesive soils which are to be removed from the sampling tubes should be extruded immediately after the sample has been withdrawn from the borehole. A delay in removing cohesive materials from the tube allows adhesion and friction to develop between

the sample and sampling tube. The result may be greater than normal sample disturbance due to the extrusion process.

Prior to extruding the sample, the bottom end of the soil sample should be trimmed properly so that the sample extruding piston fits against a plane surface perpendicular to the axis of the sample. The sample should be extruded from the sampling tube in the same direction as it was sampled using one smooth, uniform stroke of the jack to minimize sample disturbance. The sample should be extruded onto a half-section receiving tube made from a tube of the same diameter as the sampling tube. The sample then can be examined, the classification and stratification of the sample can be noted, and the sample preserved for shipment to the laboratory. Logging time must be kept to a minimum to prevent moisture loss, slaking, etc.

The use of hydraulically activated sample jacks is the most satisfactory method for extruding soil samples from the sampling tube. Mechanical sample jacks should be used only when hydraulic pressure is not available. Pneumatically activated sample jacks are not satisfactory for extruding undisturbed samples from sampling tubes. The pressure required to overcome the frictional forces between the sample and the sampling tube is usually considerably greater than the pressure required to extrude the sample. Once the frictional forces have been overcome, the compressed air in the pneumatic cylinder ejects the sample too rapidly. Serious sample disturbance frequently occurs. Figure 6-7 shows a hydraulic sample jack operated by the hydraulic system of the drill rig. Figure 6-8 shows a manually operated mechanical sample jack.

Cohesive samples which have been extruded from the sampling tube may be placed in wax-coated cardboard tubes which are approximately 25 mm (1 in.) larger in diameter than the sample itself. A wax mixture, such as a 1:1 mixture of paraffin and microcrystalline wax, should be placed around the soil sample to minimize changes of water content and disturbance of the sample. The temperature of the wax should be less than about 10 deg C (18 deg F) above its melting point, as wax that is too hot penetrates the pores and cracks in the soil and limits the usefulness of the samples. Qualitatively, an object such as a pencil that is inserted in wax at the proper temperature for coating samples will be coated with congealed wax immediately upon withdrawal; the wax coating will not bond to the object. If the wax is too hot, it will appear clear and bond to the object.

The sample must be placed carefully into the cardboard sample tube to prevent damage to the sample. The sample should be centered in the tube to ensure a continuous coating of wax. Premolded wax base plugs, which are shaped to aid in centering the sample, eliminate the need for pouring a base of wax in the tube. After the sample has been placed in the tube and centered, a small amount of wax may be poured around the sample to soften the base to assure bond between pours. The annular space between the sample and the sampling tube should be filled and the top of the sample should be covered with wax. In general, the sample should not be wrapped with foil or plastic. However, a material which is too friable to handle may be wrapped with cheesecloth for added strength as required for handling.

6-6. Boring and Sampling Records

After the soil samples have been removed from the sampling apparatus, visually identified according to the procedures and methods which are presented in Appendix E of this manual, and sealed in appropriate sample containers, the sample containers should be identified and labeled and the boring logs should be updated.

All tubes and samples should be labeled immediately to ensure correct orientation and to accurately identify the sample. ENG Form 1742 and/or ENG Form 1743, as shown in Figure 13-1, should be completed and securely fastened to each sample. The information on the sample identification tag should include project title and location, boring and sample number, depth and/or elevation interval, type of sample, recovery length, trimmed sample length, sample condition, visual soil classification, date of sampling, and name of inspector. All markings should be made with waterproof, nonfading ink. Pertinent boring information and sample data, as discussed in paragraph 13-3, must be recorded in the boring log.

In addition to the aforementioned data which were placed on the sample identification tag, clear and accurate information which describes the soil profile and sample location should be documented in the boring logs. Record any information that may be forgotten or misplaced if not recorded immediately, such as observations which may aid in estimating the condition of the samples, the physical properties of the in situ soil, special drilling problems, weather conditions, and members of the field party. Figure 6-9 presents an example of a boring log of an undisturbed sample boring.

6-7. Shipment of Samples

The most satisfactory method of transporting soil samples is in a vehicle that can be loaded at the exploration site and driven directly to the testing laboratory. This method helps to minimize sample handling and allows the responsibility of the samples to be delegated to one person. Samples shipped by commercial transportation companies require special packing or crating, special markings, and instructions to ensure careful handling and minimum exposure to excessive heat, cold, or moisture. In general, jar samples from the bottom of the tube samples can usually be packaged in containers furnished by the manufacturer, although special cartons may be required if considerable handling is anticipated. Undisturbed sample tubes should be packed in an upright orientation in prefabricated shipping containers or in moist sawdust or similar packing materials to reduce the disturbance due to handling and shipping. For certain cases, special packing and shipping considerations may be required. Regardless of the mode of transportation, the soil samples should be protected from temperature extremes and exposure to moisture. If transportation requires considerable handling, the samples should be placed in wooden boxes. Additional guidance is presented in Chapter 13 and in ASTM D 4220-83, "Preserving and Transporting Soil Samples" (ASTM 1993).



Figure 6-1. Photograph of a screw-type earth anchors



Figure 6-2. Photograph of screw-type earth anchors fastened to the drill rig with load binders to anchor the rig

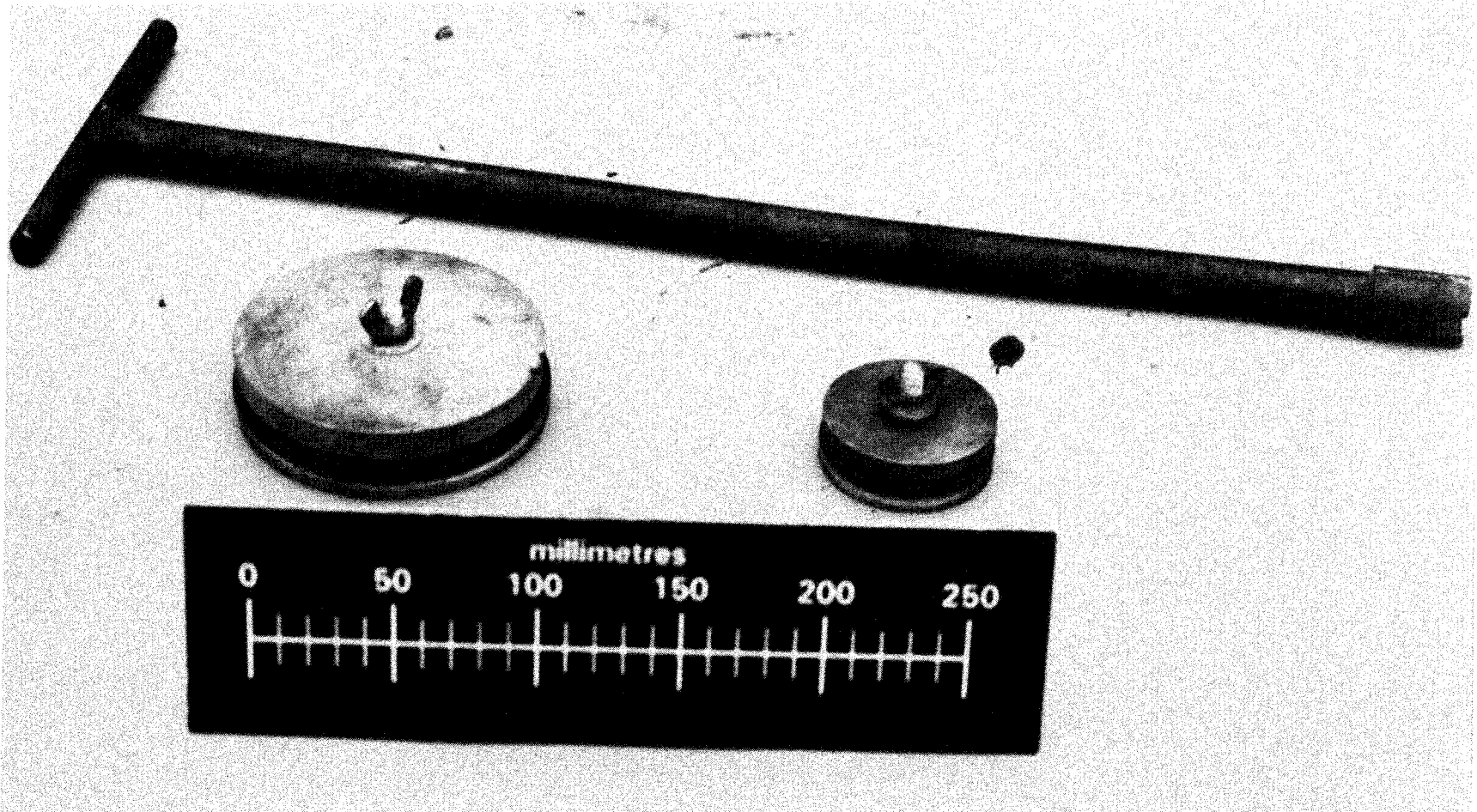

Figure 6-3. Photograph of an expandable packer

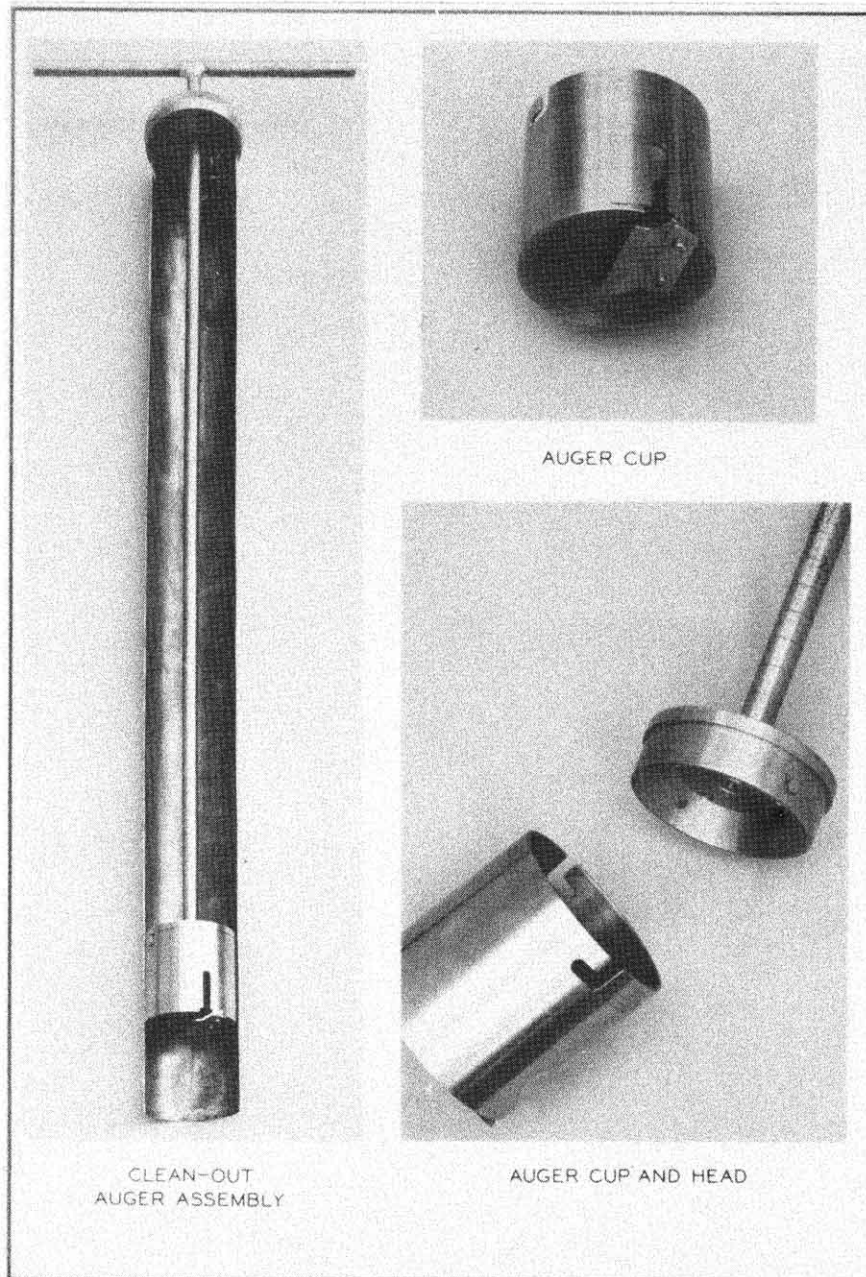

Figure 6-4. Photograph of a cup cleanout auger which is used to remove material from the bottom of the sampling tube

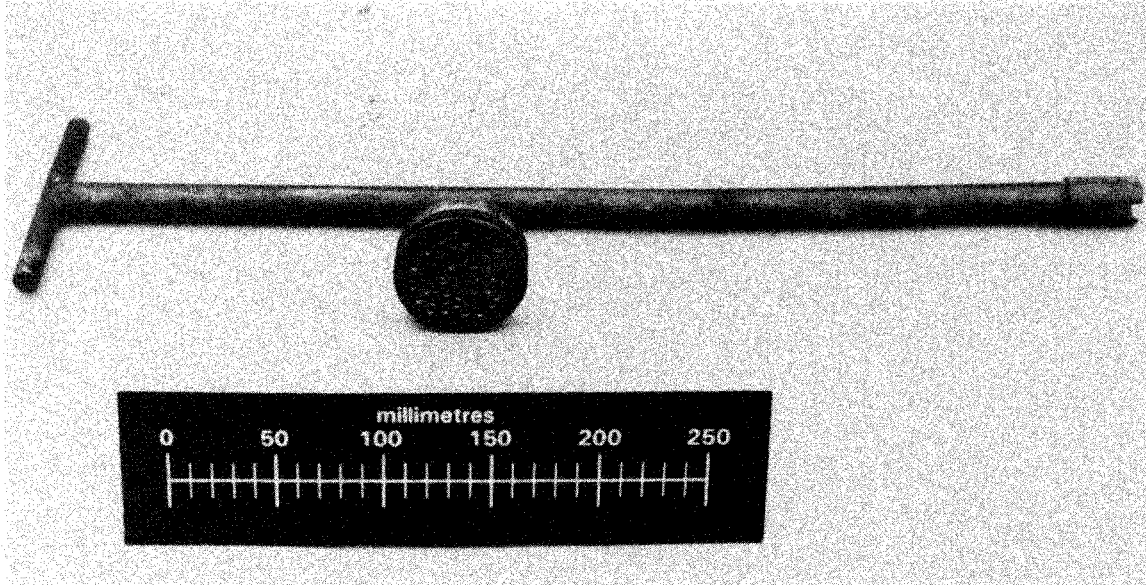

Figure 6-5. Photograph of a perforated, expandable packer

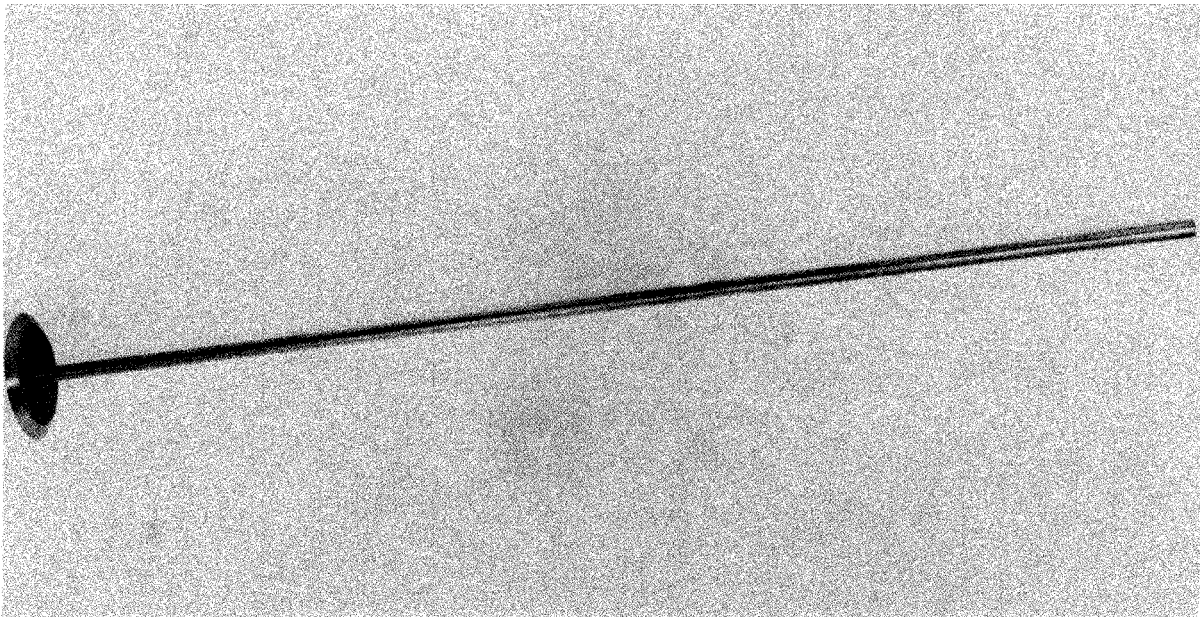

Figure 6-6. Photograph of a sampling tube wall scraper

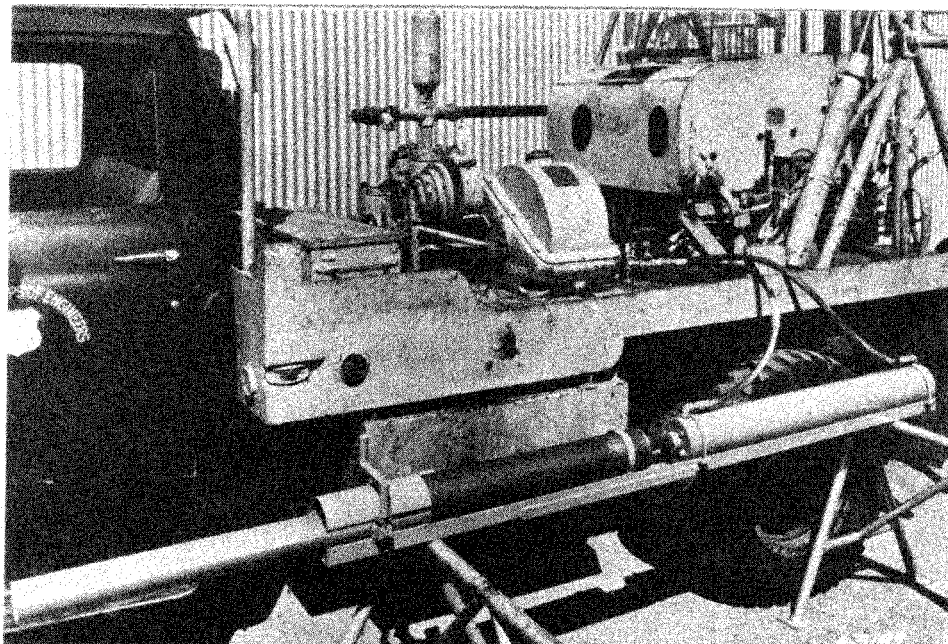

Figure 6-7. Photograph of a hydraulic sample jack which is operated by the hydraulic system of the drill rig

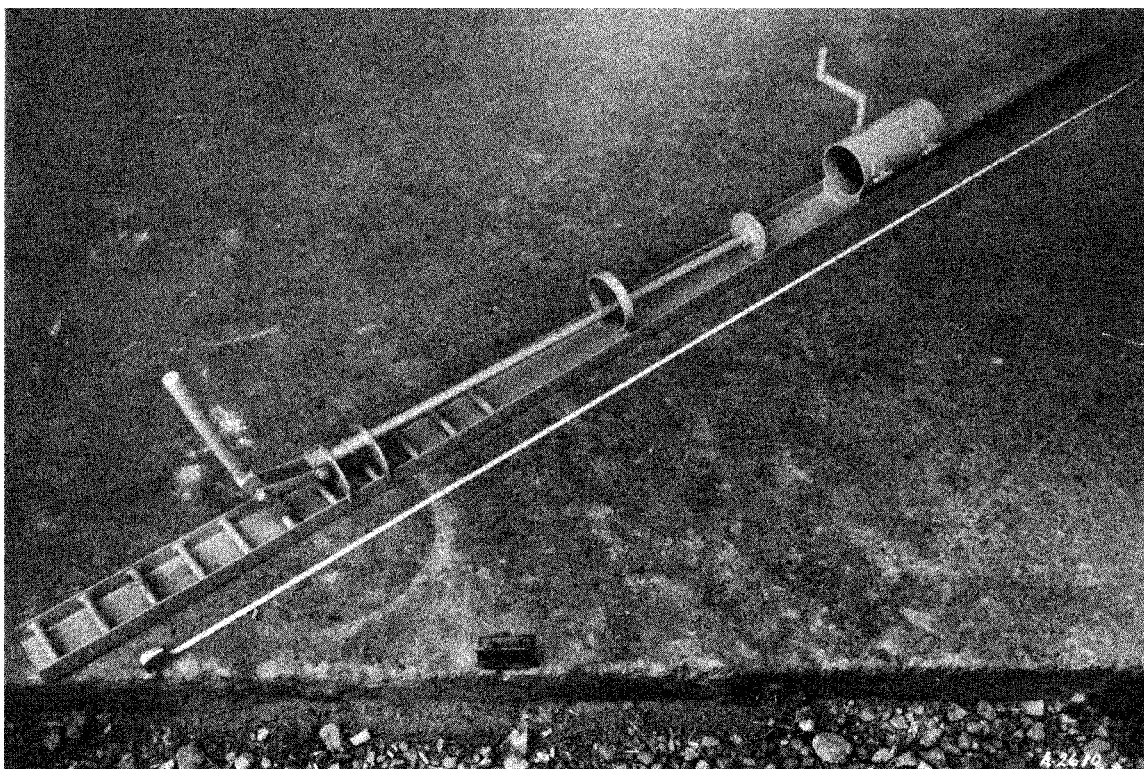

Figure 6-8. Photograph of a manually operated mechanical sample jack

| BORING LOG
FIELD DATA | | | | | | | | | | | | | | | |
|-----------------------------------------|------------|---------|------|-----------------------------------------|------|--------|------|--------------------------|-----------|-----------------------------|------------------------------------------------|----------------------------------|--|--|--|
| Project <u>Morville Revetment Slide</u> | | | | Location <u>Range 2, Riverside 400'</u> | | | | Date <u>16 July 1971</u> | | | | | | | |
| Drill Rig <u>W-4048</u> | | | | Inspector <u>Elliot</u> | | | | Operator <u>Brown</u> | | | | Surface elev <u>58.0 ft. MSL</u> | | | |
| Levee District <u>Concordia</u> | | | | Job No. <u>7063</u> | | | | Boring No. <u>MR-1</u> | | | | | | | |
| SAMPLE NUMBER | DATE TAKEN | STRATUM | | DRIVE | | SAMPLE | | TYPE OF SAMPLER | CONTAINER | HYDRAULIC PRESSURE OR BLOWS | CLASSIFICATION AND REMARKS | | | | |
| | | FROM | TO | FROM | TO | FROM | TO | | | | | | | | |
| - | 16 July | 0.0 | 11.5 | 0.0 | 12.0 | - | - | 6" Fishtail | - | - | Brown silty clay, stiff Cl | | | | |
| 1 | 16 July | 11.5 | | 12.0 | 12.5 | 12.0 | 13.2 | 5" Shelby Tube | Tube | 20 | Gray clay, med. CH | | | | |
| 1A | | | | 12.5 | 13.0 | 13.2 | 13.3 | " | Jar | 80 | | | | | |
| | | | | 13.0 | 13.5 | | | | | 100 | (Drive, 2.50'; Sample, 2.50'; | | | | |
| 2 | | | | 13.5 | 14.0 | 13.3 | 14.4 | " | Tube | 160 | Gap between Sample | | | | |
| 2A | | | | 14.0 | 14.5 | 14.4 | 14.5 | " | Jar | 180 | & Piston, 0.00') | | | | |
| - | | | 16.2 | 14.5 | 16.5 | - | - | 6" Fishtail | - | - | Gray clay, med. CH | | | | |
| 3 | 16 July | 16.2 | | 16.5 | 17.0 | 16.5 | 18.9 | 3" Shelby Tube | Tube | 100 | Gray sand, fine SP | | | | |
| | | | | 17.0 | 17.5 | | | | | 160 | (Drive, 2.48'; Sample, 2.42'; | | | | |
| | | | | 17.5 | 18.0 | | | | | 200 | Gap 0.06') | | | | |
| | | | | 18.0 | 18.5 | | | | | 280 | (Mud Wt. 70.0 Lb/Cu Ft.) | | | | |
| | | | | 18.5 | 19.0 | | | | | 320 | | | | | |
| - | 16 July | | | 19.0 | 22.0 | - | - | 3 1/2" Fishtail | - | - | Gray sand, fine SP
(Mud Wt. 71.0 Lb/Cu Ft.) | | | | |

WES FORM NO. 819
REV FEB 1971

Sheet 1 of 4 Sheets

Figure 6-9. An example of a boring log of an undisturbed sample boring

Chapter F-7 Equipment for Disturbed Soil Sampling In Borings

7-1. Sampler Type

Various types of augers and drive and displacement samplers are available for obtaining disturbed samples of most soils. In general, the equipment (and procedures) for obtaining disturbed samples of soil are similar (or perhaps require minor modifications) to the equipment and methods which were discussed in Chapters 5 and 6 for undisturbed sampling operations. The most satisfactory type of sampler depends upon the nature of the material to be sampled, the purpose for which the sample is intended, and the type of drill rig which is used. Procedures for obtaining disturbed samples are discussed in Chapter 8.

7-2. Augers

Augers may be used for obtaining disturbed samples in all types of soils except clean cohesionless sands and gravels with little apparent cohesion or those soils in which the borehole will not remain open. Augers are best suited for sampling above the water table. Samples are taken directly from the auger upon its withdrawal from the hole. Augers are generally available in sizes from 25- to 75-mm- (1- to 3-in.-) diam for hand-held devices to 2.4-m- (96-in.-) diam or larger for machine-operated helical and disk augers. A photograph of a bucket auger drill in operation is presented in Figure 3-10.

a. Hand augers. Iwan-type posthole augers and light helical augers are used for shallow borings. Figure 7-1 is a photograph of Iwan augers.

b. Barrel augers. Barrel-type augers may be used with drill rigs to obtain disturbed samples of most cohesive soils above and below the water table. The Vicksburg solid and hinged augers and the McCart split auger, as shown in Figures 7-2 and 7-3, respectively, are typical barrel-type augers. The Vicksburg and McCart augers are fashioned after the Iwan auger and are equipped with rigid overlapping curved blades at the bottom of the barrel. The blades of the Vicksburg hinged auger are held together during augering operations by a hinge and slip ring. The blades of the McCart auger are held together by a bolt. Split augers are especially adapted for removal of sticky soil from the auger barrel. However, split augers are not strong enough to be used in hard or stony soils.

c. Helical augers. Helical augers, which are sometimes called worm-type augers, may be used with drill rigs to obtain disturbed samples of cohesive soils from above or below the water table. The auger consists of a stem onto which the helical fluting or auger flights are wrapped. A drive head is attached to one end of the stem; fluting, pilot bit, and cutting teeth are attached to the other end. As the names imply, the auger stem may be either solid or hollow; the fluting may consist of as few as one revolution of the fluting or one flight to continuous fluting over the total length of the stem. Figure 7-4 is a photograph of a short-flight solid-stem auger. Figure 7-5 is a photograph of segments of a continuous-flight hollow-stem auger and a continuous-flight solid-stem auger.

The operations of the short-flight and the continuous-flight augers are similar. The principal difference is the method in which the soil is brought to the ground surface. For the short-flight auger, the auger must be returned to the surface each time the flights are filled with soil. The principal advantage of the short-flight auger is a better knowledge of changes of strata. The disadvantage of this method is that the auger must be removed from the borehole each time the flights are filled with soil. The advantage of the continuous-flight auger is that the soil is automatically brought to the ground surface by the rotation of

the auger as it penetrates. However, the quality of soil samples may be of questionable value because of the potential for mixing soils from different strata.

The hollow-stem auger may be used as casing to prevent caving of unstable soils. After the boring has been advanced to the desired depth, the center rod and pilot bit are removed. A sampling device can be operated through the stem of the auger.

d. Bucket augers. A bucket auger consists of a relatively short barrel which is open at the top and equipped with cutting teeth attached along slots on a hinged drop bottom. Two designs for the slots in the bottom of the bucket are available. For cohesive materials, open slots are located ahead of the cutting teeth. For cohesionless materials or for drilling below the water table, hinged steel or rubber flaps are used to cover the slots in the bottom of the bucket to prevent the loss of material. To fill, the bucket is rotated and the flaps pivot upward to allow the material to enter. When the bucket is filled, it is pulled out of the borehole and moved away from the rig by a dump arm before it is emptied. Figure 7-6 is a schematic drawing of several types of bucket augers. Figure 7-7 is a schematic drawing of a hinged drop-bottom bucket which was designed for rapid removal of cohesive or cohesionless soil from the bucket.

A variety of types of bucket augers are available for specific tasks. For example, bellings buckets are used for underreaming, such as when a larger diameter of borehole is needed at depth. To activate the bellings bucket, downward pressure is applied by the Kelly to open the reamers. Other types of buckets include those for picking up large boulders and buckets to chop hard materials. Examples of the use of bucket augers include drilling large-diameter accessible borings, boreholes for cast-in-place piles, water wells, and pressure relief wells near Corps structures.

7-3. Push or Drive Samplers

Push or drive samplers, which are pushed or driven into the soil without rotation, may be used for obtaining disturbed samples of most soils. Push-tube samplers can be subdivided into two broad groups: open samplers and piston samplers. Open samplers consist of a vented sampler head attached to an open tube which admits soil as soon as the tube is brought in contact with the soil. The sampler head itself may be equipped with a ball check valve which creates a partial vacuum that aids in sample recovery and prevents the entrance of drilling fluid during sample withdrawal. Some open samplers are equipped with a cutting shoe and a sample retainer. Piston samplers have a movable piston located within the sampler tube. The piston helps to keep drilling fluid and soil cuttings out of the tube as the sampler is lowered into the borehole. The piston also helps to retain the sample in the sampler tube.

As compared to piston samplers, open samplers have advantages due to cheapness, ruggedness, and simplicity of operation. The principal disadvantage of open-drive samplers include the potential for obtaining nonrepresentative samples because of improper cleaning of the borehole or collapse of the sides of the borehole.

a. Open samplers. Various types of pushed or driven open samplers are available. The sampling tube may be either thick-walled or thin-walled. In most instances, split-tube samplers are preferred because the two halves can be separated to observe soil stratification. Sample retainers may be required for sampling sand, gravel, and very soft or friable soils. The type of open-drive sampler which is selected depends upon availability and experience, location and accessibility of borehole, and the soil to be sampled.

(1) *Thin-walled samplers.* The thin-walled open sampler consists of a tube affixed to a sampler head assembly which may or may not be equipped with a check valve. Most sampling tubes are drawn to provide a suitable inside clearance, although this “requirement” is only necessary for undisturbed sampling operations. These tubes normally have an OD of 75 to 125 mm (3 to 5 in.) and a length of 76 to 91 cm (30 to 36 in.). Thin-walled tubes are sharpened on one end and therefore, may be easily damaged by buckling or by blunting or tearing of the cutting edge as they are driven into stiff or stony soils. To reduce the potential for damage, the tube should be pushed rather than driven. Hence, the basic principle of operation of the thin-walled sampler is to force the cylindrical tube into the soil in one continuous push without rotation.

Thin-walled open-drive samplers may be used to obtain samples of medium-to-stiff cohesive soils. Soils which cannot be sampled with this device include soils which are hard, cemented, or too gravelly for sampler penetration, or soils which are so soft or wet that the sample will not stay in the tube.

(2) *Thick-walled samplers.* A large number of thick-walled samplers are available. The most-well known split-tube or split-barrel type sampler is the split-spoon sampling tube which is used with the SPT, as described in Appendix G of the Geotechnical Manual. Another thick-walled sampler includes the California sampler.

Thick-walled split-spoon samplers of various sizes have been used extensively for obtaining disturbed samples of all types of soil, both above and below the water table. The sample-tube barrel is threaded on both ends and split lengthwise. When assembled, the two halves are held together by the driving shoe at one end and the head at the other end. A space is provided in the driving shoe for a spring basket-type sample retainer.

Split-spoon samplers are commercially available in 50- to 115-mm (2- to 4-1/2-in.) OD sizes. The 51-mm (2-in.) OD by 35-mm (1-3/8-in.) ID split-barrel sampling tube which is used for the SPT gives good representative disturbed samples of all soil types except gravel and gravelly soils. Larger sizes of samplers are used to obtain samples of material containing gravel or large-volume samples. Except for the requirements imposed for the SPT, the sampling spoons can be driven with any convenient weight hammer. Figure 7-8 shows two sizes of split-spoon samplers and various types of sample retainers.

b. Piston samplers. Piston-type samplers perform satisfactorily in obtaining disturbed samples of most types of soil. By locking the piston at the bottom of the sample tube, piston samplers can also be used as displacement samplers. Piston samplers are discussed in paragraph 5-1a(2).

7-4. Displacement Samplers

The Memphis and the Porter samplers are retractable-plug displacement samplers. With the plug locked at the bottom of the sampler, the sampler is driven to the desired sampling depth. To sample, the plug is retracted and the sampler is driven to obtain the sample. These samplers are intended for manual operations in soft soils and are limited for use to a depth of about 10 m (33 ft). Both samplers have a 32-mm (1-1/4-in.) OD by 25-mm (1-in.) ID barrel and cutting shoe and are equipped with an extension pipe of the same diameter as the barrel. The Porter sampler is fitted with a segmented brass liner consisting of seven, 150-mm- (6-in.-) long segments. Each liner segment is 25-mm (1-in.) OD by 24-mm (15/16-in.) ID. Caps are provided for sealing the individual segments of samples after recovery.

7-5. Vibratory Samplers

A variety of large-scale and small-scale vibratory samplers offers rapid, inexpensive methods of obtaining disturbed, and usually representative, samples of saturated, cohesionless materials, i.e., silts and fine sands found in barrier islands and deltaic deposits which are often inaccessible by conventional drilling and sampling equipment. The principle of operation consists of the application of a vibrating or oscillating energy to the sampling tube rather than the application of a brute force, such as by a percussion hammer or hydraulic drive. The oscillation of the sampling tube tends to induce positive pore pressures which result in a reduction of the effective stresses within the material to be sampled. For the hand-operated sampler, a small gasoline engine designed for use as a concrete vibrator is the power source of the system. A flexible shaft attaches the motor to the vibrator head mounted on the sampling tube. A tripod, which consists of a tripod headplate and legs, is required to support the sampling tube during sampling operations and to provide a reaction frame for extracting the sampling tube and sample from the borehole. The system uses thin-walled aluminum sampling tubes of various lengths and diameters that are commercially available. The use of vibratory samplers has made it possible to obtain inexpensive representative disturbed soil samples to depths in excess of 10 m (33 ft) at sites, such as unconsolidated backswamp deposits, previously considered to be inaccessible to most drilling and sampling equipment. Figure 7-9 is a photograph of a portable vibratory sampler. Additional information is presented in paragraphs 8-2 and 10-5.

7-6. Percussion Samplers

Percussion drilling, which includes the use of churn or cable-tool drills, wireline drills, and hammer drills, such as the Becker hammer and the eccentric reamer system, may be used to advance borings for disturbed sampling in hard cohesive soils, cemented sands and gravels, and gravelly soils. Samples obtained with a bailer or from the return wash water in percussion borings are not satisfactory as disturbed samples because the finer materials will be suspended in the water. Therefore, drive samplers or core barrels are required for obtaining disturbed samples from a borehole advanced by a churn drill. When the Becker hammer drill is used, disturbed samples may be taken from the return cuttings. However, these samples are a mixture of all soil materials in the depth interval from which the particular sample was obtained.

a. Wireline samplers. Wireline samplers are similar to other percussion-type hammer samplers except that the entire sampling assembly, including the hammer, drive head, and sampling tube, is lowered into the borehole to obtain the sample. The hammer is activated by a cable attached to the surface. This type of system is particularly adapted for deep borings and nearshore drilling because the drill rods do not have to be assembled and disassembled each time a sample is obtained. A variety of sampling tubes and various hammers have been successfully used to obtain representative disturbed samples of all soils except those containing large gravel. Figure 7-10 illustrates a split-spoon sampler with a New Orleans wireline drive hammer.

b. Hammer drills. Several hammer drills are available for obtaining disturbed samples of soil and fragmented rock. The most widely recognized hammer drills are the Becker hammer drill and the eccentric reamer (ODEX) system. Both drilling systems are patented and are discussed in detail in paragraph 3-3*d*. The use of the Becker hammer drill as a penetration test is discussed in Appendix H of the Geotechnical Manual.

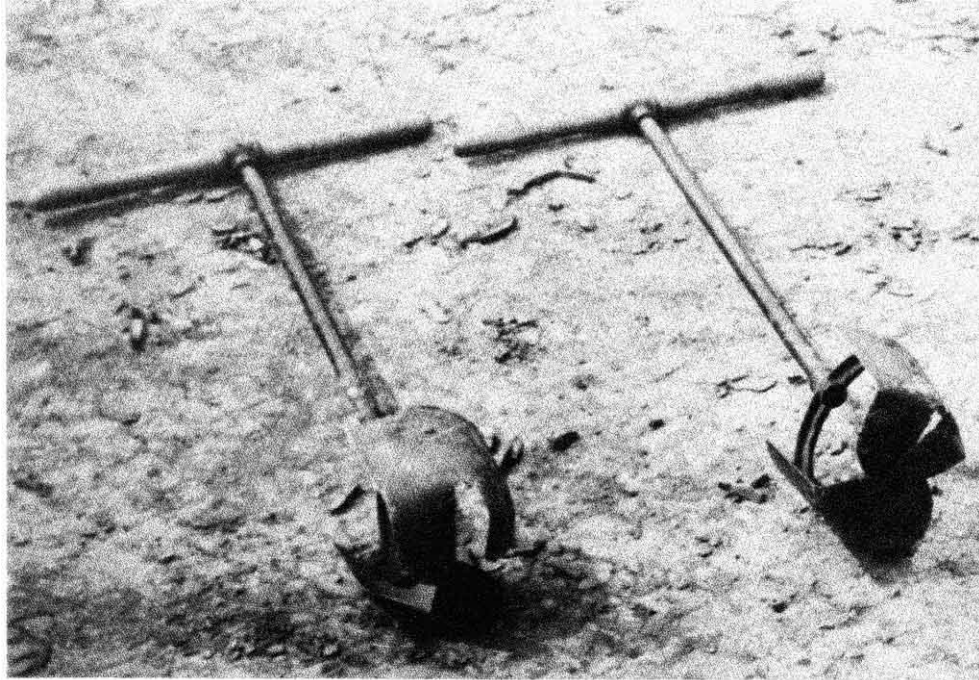

Figure 7-1. Photograph of an Iwan auger

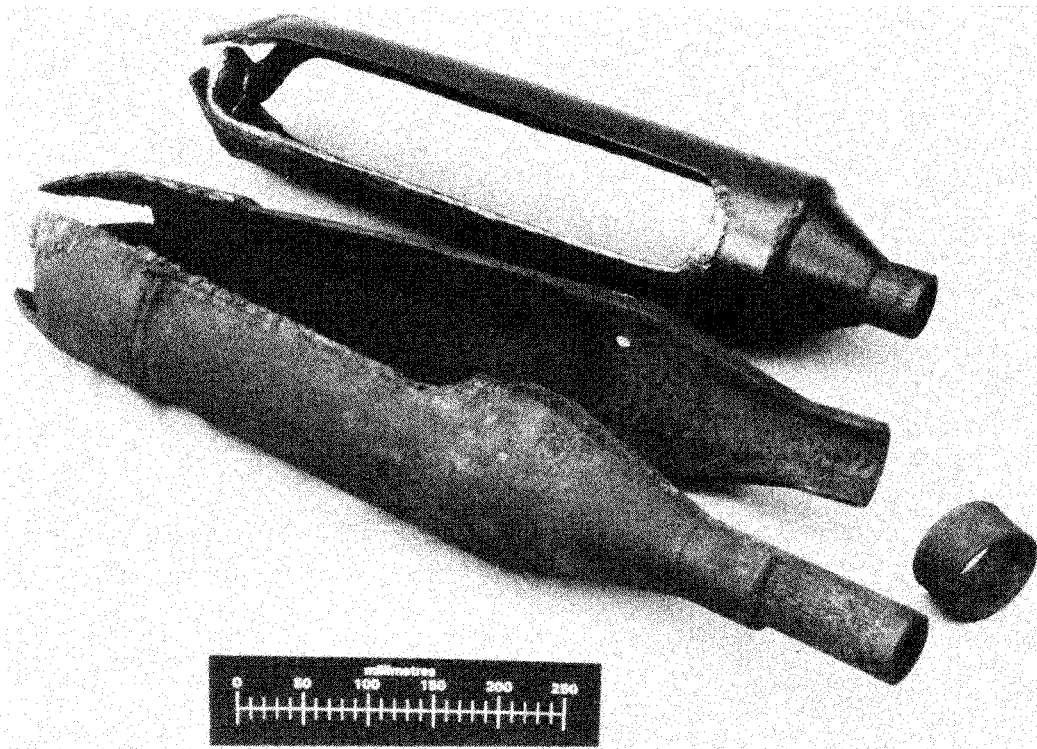

Figure 7-2. Photograph of the Vicksburg solid and hinged barrel-type augers

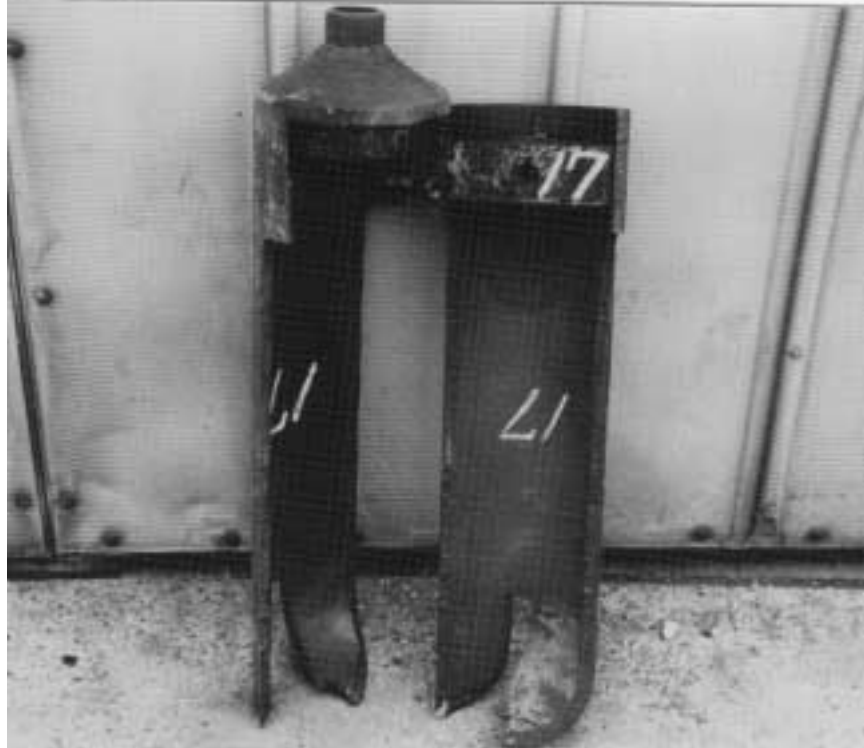

Figure 7-3. Photograph of the McCart split barrel-type auger

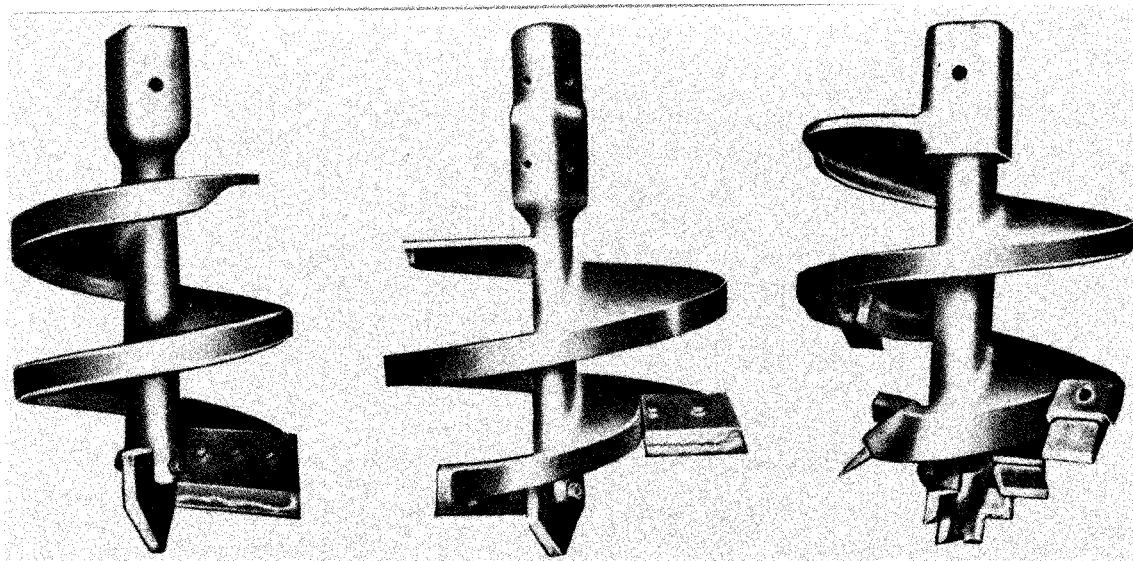

Figure 7-4. Photograph of short-flight solid-stem augers

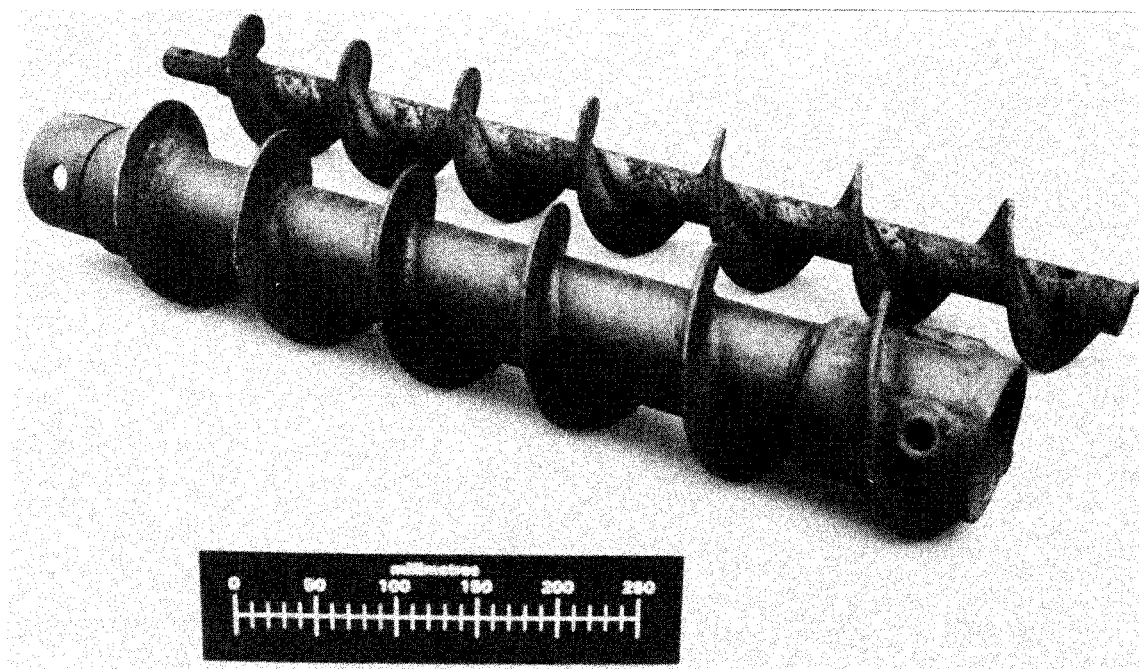

Figure 7-5. Photograph of segments of a continuous-flight solid-stem auger and a continuous-flight hollow-stem auger

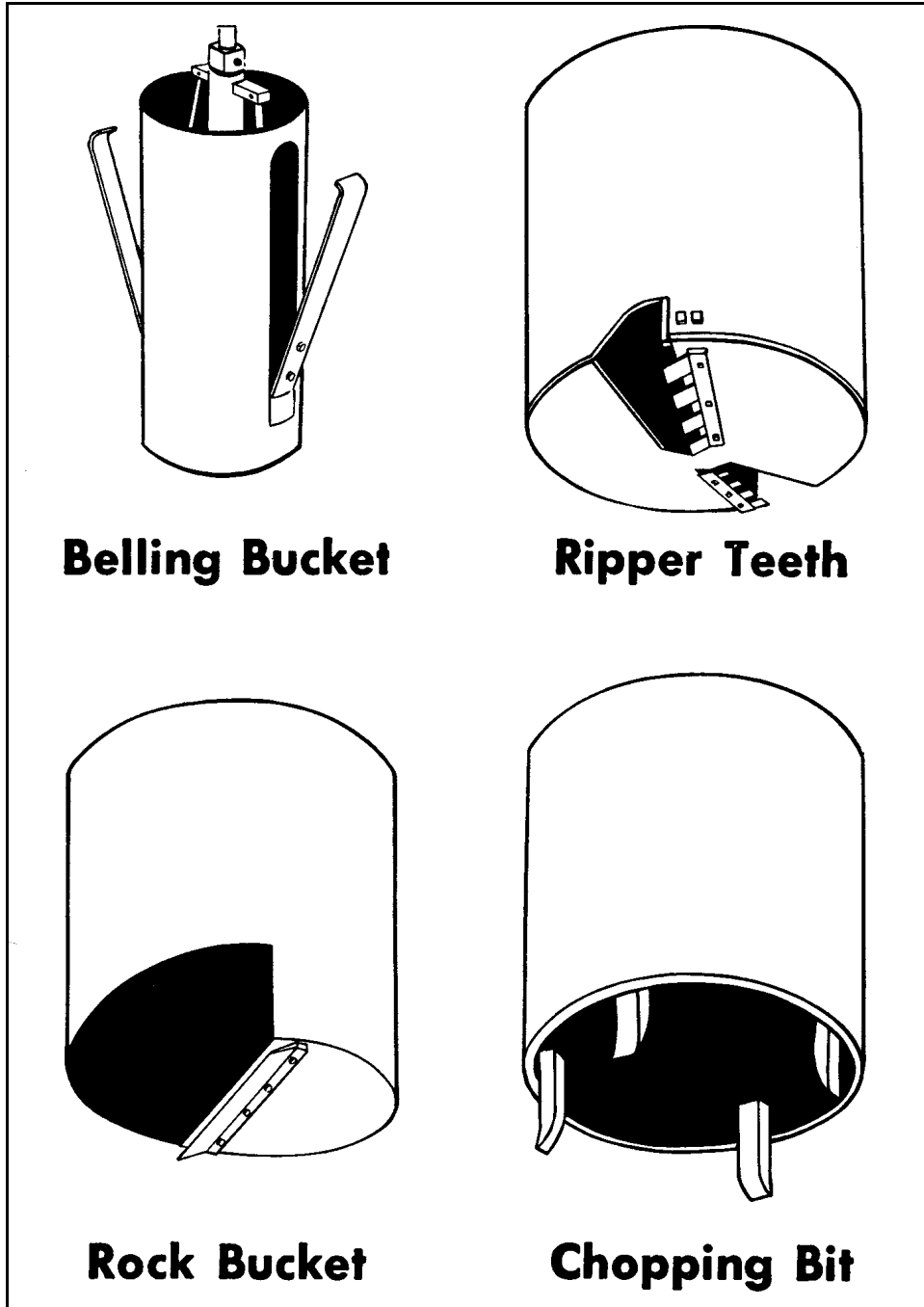
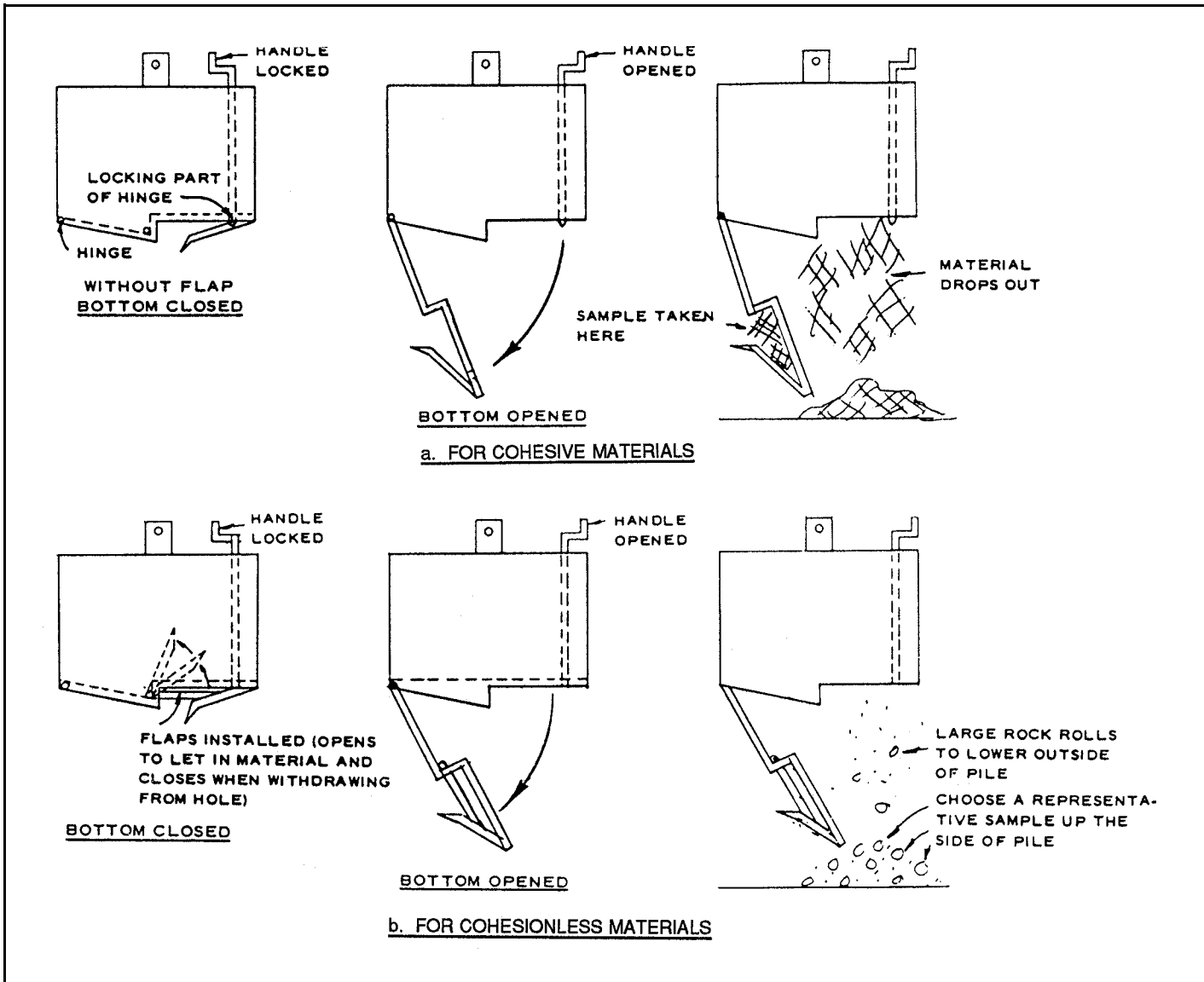

Figure 7-6. Isometric drawing of several types of bucket augers



F-7-9

Figure 7-7. Schematic drawing of hinged drop-bottom buckets which were designed for rapid removal of cohesive or cohesionless soils

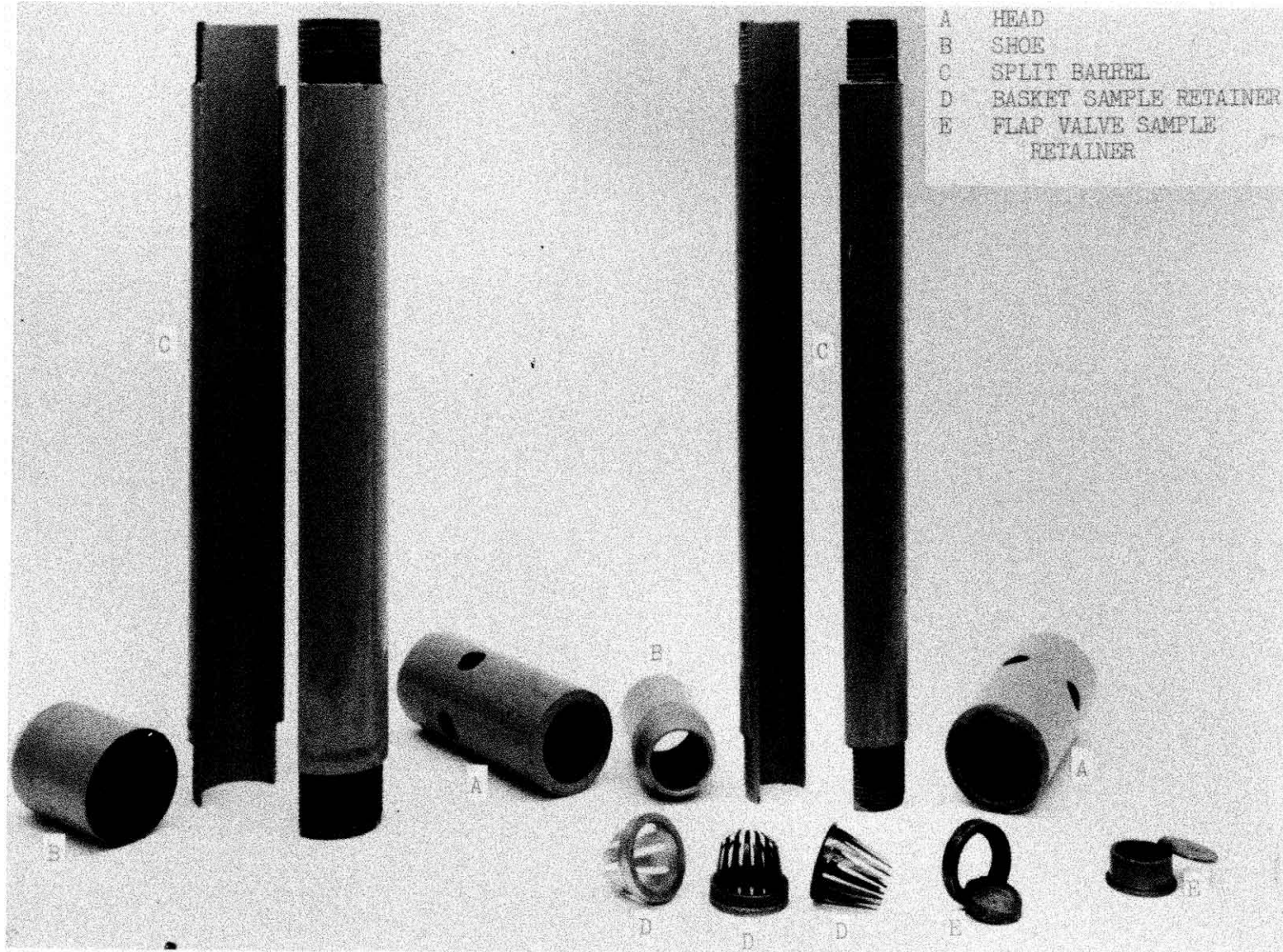

Figure 7-8. Photograph of two split-spoon samplers and several sample retainers



Figure 7-9. Photograph of a portable vibratory sampler (after Smith, Dunbar, and Britsch 1986). Note: Safety is a very important consideration for Corps of Engineers projects. Safety items, including hardhats, gloves, safety shoes, protective clothing, and dust or vapor masks, should be worn, as appropriate, for the particular drilling and sampling operation

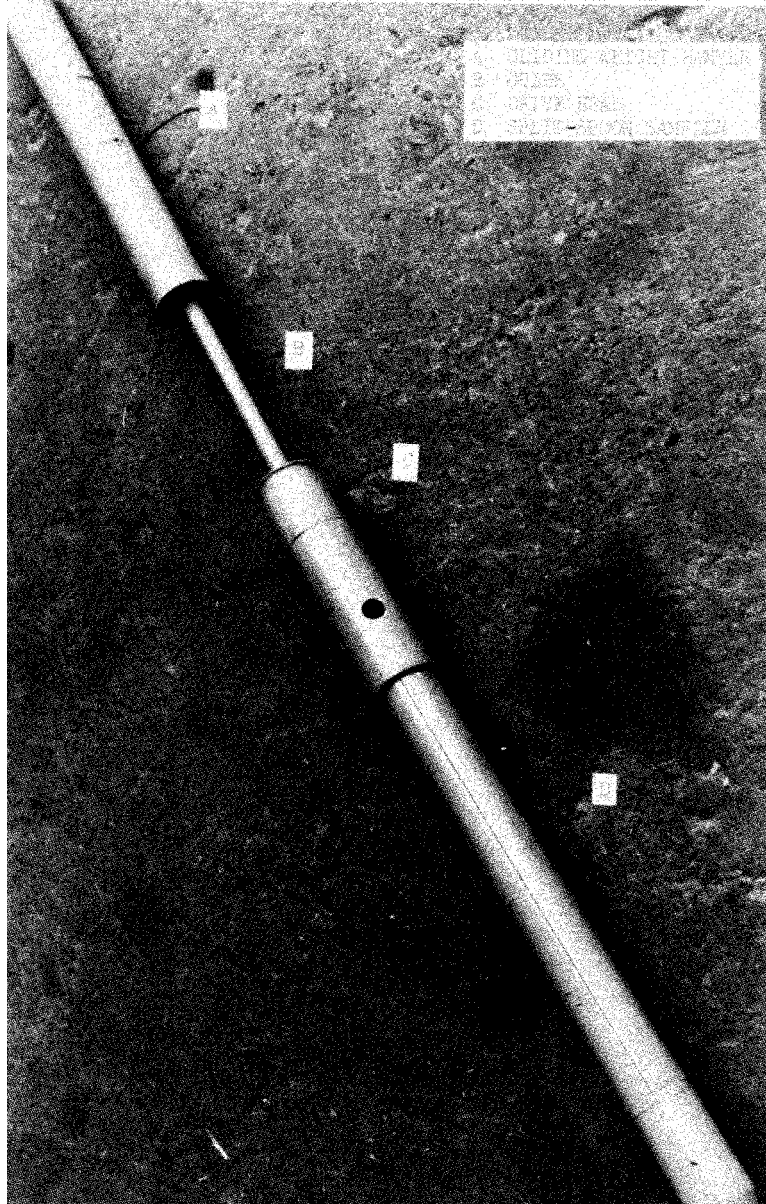

Figure 7-10. Photograph of a split-spoon sampler with a New Orleans wireline drive hammer

Chapter F-8 Procedures for Disturbed Soil Sampling In Borings

8-1. Advancing the Borehole

Boreholes for disturbed soil samples may be advanced in the same manner as those procedures used for boreholes for undisturbed soil samples. After a vertical pilot hole has been established, if necessary, attach the drill bit or auger to the drill rod and lower the string into the borehole. Attach more drilling rods as necessary. At the bottom of the borehole, perform drilling operations to advance the hole to the desired depth. After the hole has been advanced, remove the excess cuttings before the drill string is withdrawn from the borehole. As the drill string is withdrawn from the hole, disconnect the sections of rod and lay aside. Repeat until the cutting head is retrieved.

When lowering the equipment into the borehole, count the number of rods to determine the depth of the borehole. Carefully monitor and record the depth of the hole for use during the sampling operations as the vertical location of the sample is needed. All trips in and out of the borehole should be made without rotation of the drill string.

The methods and procedures for cleaning boreholes for disturbed sampling operations are similar to the procedures for cleaning boreholes for undisturbed sampling operations. Boreholes may be cleaned by rotary drilling and augering methods as previously reported in Chapter 6. Bailers or sand pumps may also be used to clean cased holes provided that bailing is controlled to prevent the disruption of the soil that is to be sampled. A clean, open hole is essential for obtaining satisfactory samples; disturbance of the soil at the sampling depth is not critical unless it results in a nonrepresentative sample.

a. Diameter of the borehole. The diameter of the borehole should be at least 6 mm (1/4 in.) greater than the OD of the sampler or casing, if casing is used.

b. Methods of advance. Boreholes for disturbed samples may be advanced by augering, rotary drilling, displacement, or churn drilling. Hammer drilling is gaining acceptance for drilling in certain soils, such as gravelly soils. However, samples are generally not recovered as a part of the hammer drilling operations. Therefore, hammer drilling is not discussed in this chapter; equipment and procedures for hammer drilling are discussed in paragraph 3-3*d*. The use of the Becker hammer drill as a penetration test is discussed in Appendix H of the Geotechnical Manual..

(1) *Augering.* Augers may be used to obtain disturbed samples of the in-place soil. However, the samples may not be representative of the in situ formation due to the mixing action of the auger. The structure of the soil may be completely destroyed and the moisture content of individual soil strata layers encountered may be changed.

A large number of augers are available. In addition to handheld augers, such as the Iwan or posthole type, helical and tubular augers which are described in Chapter 7, machine-driven augers including single- or continuous-flight (spirals) solid-stem or hollow-stem augers, disk augers, and bucket or barrel augers may be used to advance boreholes for disturbed samples in the same manner as described for advancing boreholes for undisturbed samples in paragraph 6-1*b*.

Auger borings are generally used in soils where the borehole will remain open, usually above the groundwater table. Below the groundwater table, drilling fluid or casing may be required to stabilize the borehole. Because auger borings typically do not use drilling fluid, the augering method may be preferred for drilling holes in embankment dams; the absence of drilling fluid eliminates the potential for hydraulic fracturing.

Augers operate best in somewhat loose, moderately cohesive, moist soils. In general, the holes are bored without the addition of water, although the introduction of a small amount of water may aid in drilling, especially in hard, dry soils or cohesionless soils. If water is added to the borehole, it should be noted on the boring logs.

(2) *Rotary drilling.* The method of advancing the borehole by rotary drilling consists of rotation and application of downward pressure on the drill bit or cutting shoe which is attached to the bottom end of the drill string. Drilling fluid, such as compressed air or drilling mud, must be used to remove the cuttings from the face of the drill bit and out of the borehole. Bottom discharge rotary bits are not acceptable for advancing the borehole. Side discharge bits may be used with caution. Jetting through an open-tube sampler to clean out the borehole to sampling depth is not permitted. Prior to sampling, the loose material from the hole must be removed as carefully as possible to avoid disturbing the material to be sampled. As a rule of thumb, boreholes may be advanced in the same manner as for undisturbed samples which is described in paragraph 6-1; cleaning of the borehole prior to sampling is discussed in paragraph 6-3.

Boreholes in soft or loose soils or when the boring is extended below the groundwater level may be stabilized with casing or drilling mud. Procedures and requirements for casing are similar to those described in paragraphs 3-4*d* and 6-2*b*. However, only disturbed samples shall be taken when the casing is driven in the boreholes.

If the casing is driven, the driving hammer is usually 113 to 181 kg (250 to 400 lb). Other equipment which is needed includes a driving shoe, a driving guide, and an assembly to pull the casing. Before the casing is driven, a small flat area should be shoveled on the surface of the ground and a short piece of casing should be selected. While the casing is held steady, the cathead or wire drum can be used to lift and drop the hammer to drive the casing. After several sections of casing have been added, rotate the casing clockwise. This operation tends to free the casing and make it easier to drive. The casing should not be driven to a depth greater than the top of the next sample interval.

After the casing has been placed, the inside of the casing must be cleaned. Wash boring and rotary drilling with fluid circulation methods are suitable for removing the material in the casing. If rotary drilling techniques are used, follow the procedures that are suggested in paragraph 6-2*b*. If the wash boring method is used, a water swivel and water hose should be attached to the top of the drill rods and connected to the water pump, and a chopping bit should be attached to the bottom of drill rods. After the drill rods have been lowered into the casing, circulation of drilling fluid should be started. The drill string should be raised and dropped by the cathead and rope method or by the wire drum hoist. The drill string should be rotated frequently. The jetting action of the drilling fluid will wash the material out of the casing.

After the soil in the casing has been removed, the casing should be raised slightly to allow the casing header or adapter to be removed to permit the sampler to be operated through the casing. To permit sampling through the casing, the ID of the casing must be slightly larger than the OD of the sampler. When a larger diameter casing is used, the jetting action of the drilling fluid is reduced. Thus, segregation and alteration of the intended soil sample is minimized.

(3) *Displacement methods.* Displacement samplers may be used to advance boreholes for disturbed samples. After a plug has been installed in the bottom of the sampling apparatus, the sampler is driven or pushed to the depth to which the sample is to be taken. To sample, the plug is retracted and the sampling drive is executed. For most soils, the disturbance created below the plug or sampler is not believed to be sufficient to prevent obtaining a satisfactory disturbed sample.

(4) *Percussion drilling.* The churn-drilling method, which is also called cable-tool drilling, is accomplished by raising and dropping a chisel-shaped bit attached to a heavy weight or drill bar suspended from a steel cable. A small amount of water is added to the bottom of the borehole to form a slurry with the loose material which has been chopped or dislodged by the bit. When the carrying capacity of the slurry is reached, the bit is withdrawn and the slurry is removed by bailing. More water is then added to the borehole, and the drilling and bailing segments of the operation are repeated. In soft or cohesionless soils, it is sometimes possible to advance the boring by bailing alone, although the material does not constitute an acceptable sample. When borings in fat clays are advanced, small amounts of sand may be added to increase the cutting action of the bit. Similarly, clay may be added to increase the carrying capacity of the slurry when drilling in coarse, cohesionless soils.

Casing is generally required for churn drilling and is normally driven with the churn-drill driving mechanism. The borehole is advanced ahead of the casing. If the casing is advanced ahead of the borehole, heaving at the bottom of the hole may occur. If heaving occurs, water or drilling fluid may help to stabilize the borehole, although the efficiency of the churn drill is dramatically decreased. In soft or cohesionless soils, it is often difficult to impossible to advance the borehole ahead of the casing. Furthermore, the quality of the samples may be suspect as fines will remain in suspension in the slurry. Hence, the slurry should not be considered as representative of the in situ materials.

Continuous sampling may be obtained by the churn-drilling method if the chopping bit is replaced by an open-tube sampler and the short-stroke drilling jar, which is attached between the drill bit and drill rod, is replaced by a long-stroke fishing jar. The longer jar facilitates the driving of the sampler without imparting an upward motion to the sampler. Although the borehole is advanced by the sampling operation itself, the hole must be cleaned by bailing each time the casing is advanced. Additional information is presented in paragraph 3-3*b*.

Another method of advancing the borehole by the percussion technique is hammer drilling, i.e., the Becker hammer drill and the eccentric reamer system. Since the use of these systems does not directly yield soil samples, a discussion of sampling procedures is not presented herein. However, discussions of the Becker hammer drill and the eccentric reamer system are presented in paragraph 3-3*d*; the use of the Becker hammer drill as an in situ test is discussed in Appendix H of the Geotechnical Manual.

8-2. Sampling Procedures

a. Augers. When augers (paragraph 7-2) are used as samplers for disturbed sampling operations, the auger should be carefully lowered to the bottom of the borehole to prevent dislodging material from the sidewalls of the hole. After the auger reaches the bottom of the hole, it may be advanced by rotation and a slight downward force. The speeds of advance and rotation should be adjusted to obtain maximum-size cuttings in an attempt to preserve the in situ composition of the soil to the greatest extent possible. The depth of penetration of the auger should be carefully monitored to allow for an accurate determination of the depth from which the sample is obtained.

The method of sampling with flight augers depends upon the type of auger. For single-flight augers, the auger must be carefully removed from the borehole prior to sampling. Disturbed samples can be obtained from the cuttings on the leading edge of the auger, provided that the cuttings are not contaminated with materials from other depths or segregation has not occurred because of the loss of material as the auger is removed from the borehole. Disturbed or undisturbed samples can be obtained by removing the auger from the spindle and replacing the equipment with a sampling device such as a split-spoon or thin-walled sampler. If this method is used, the depth should be carefully checked to ensure that material has not ravelled from the walls of the borehole or fallen from the auger as it was withdrawn from the hole.

For continuous-flight augers, soil can be sampled at the top of the flights of the auger, although sampling by this method is not a good practice because soil from different depths may be mixed. If a solid-stem auger is used, the auger must be removed from the borehole before a sampling device can be used to obtain disturbed or undisturbed samples. Procedures are similar to those required for sampling with the single-flight auger. If the hollow-stem auger is used, the borehole can be advanced to the desired depth, the center plug can be removed, and sampling can be conducted by lowering a wireline sampler or some other suitable sampler through the hollow stem of the auger to the bottom of the borehole. When sampling through the hollow-stem auger, the hollow stem of the auger acts as a casing. A discussion of equipment and procedures for the hollow stem auger sampler is presented in paragraphs 5-1c and 6-4c, respectively.

b. Drive samplers. Push or drive samplers (paragraph 7-3) may be advanced by pushing, jacking, or driving with a hammer. If an open-tube sampler is used, the sampler must be lowered carefully to prevent dislodging material from the sidewalls of the borehole and filling of the sampling tube before it reaches the bottom of the hole. When a piston sampler is used, procedures which are similar to those described in paragraph 6-4a for obtaining undisturbed samples should be followed. Unless a sample retainer is used with the drive-sampler assembly, it may be necessary to allow several minutes to elapse following the completion of the drive before the sampling tube is withdrawn from the formation. This delay will permit adhesion and friction between the sample and the sampling tube to develop which will help to prevent loss of the sample upon withdrawal.

c. Displacement samplers. Displacement samplers (paragraph 7-4), i.e., Memphis, Porter, or similar samplers, are assembled with a pointed plug piston fixed at the bottom of the sampler and are driven to a depth corresponding to the top of the intended sample. To sample, the pointed plug is retracted to a sampling position and the sample drive is made. A slight rotation of the piston rod following the sampling operations closes the vents; this action helps to prevent sample loss during the withdrawal of the sampler from the borehole.

d. Vibratory samplers. To obtain a sample with a vibratory sampler (paragraph 7-5), a sharpened, thin-walled tube as long as 10 m (33 ft) or more is vibrated at a frequency of approximately 2 cycles/second (120 Hz). A slight downward pressure which can be applied by hand is usually sufficient to cause a fairly rapid penetration of the sampling tube. At the completion of the drive, an expandable packer may be placed in the top of the tube to aid in sample recovery. A block and tackle attached to a guide frame can be used to extract the sample and tube from the borehole.

Before the sampling drive is initiated, the sampling tube should be oriented vertically. Verticality should be maintained during the drive to facilitate the sample withdrawal from the borehole. If extracting the sample tube is difficult, a few cycles of vibration may be applied to reduce the friction and adhesion

between the walls of the borehole and sampling tube. However, excessive vibrations should not be applied as the sample may fall from the tube.

The sample may be extruded, examined, and logged in the field or may be sealed and shipped to the laboratory for testing. If a field examination is conducted, the sample may be extruded by vibrating the slightly inclined sampling tube while simultaneously sliding a half section tray under the sharpened edge of the tube. Provided that the core trough is moved at the appropriate rate, a continuous core may be observed. If the core is to be preserved in the sampling tube, the tube should be cut into segments about 1 m (3 ft) long to facilitate handling. The ends of each segment should be sealed to preserve the in situ moisture content and stratification of the soil sample, as required by the project. Segments should be identified and boring logs updated.

e. Percussion samplers. Percussion samplers (paragraph 7-6) include wireline samplers which are driven by a sliding-weight hammer or long, weighted drilling or fishing jars. The wireline sampler and driving mechanism are lowered to the bottom of the hole, and the wireline is marked for length of intended drive. The driving mechanism is then raised and lowered by cable action in strokes slightly less than the total stroke of the hammer. When the drive is completed, the total assembly is removed from the borehole by the wireline. If the sampler becomes stuck in the soil, it can be driven upward using the hammer-drive mechanism to extract it from the formation.

8-3. Boring and Sampling Records

All pertinent borehole and sample data must be recorded in a boring log. Clear and accurate data are required to describe the soil profile and sample locations. Information and observations which may aid in estimating the condition of the samples and the physical properties of the in situ soil should be recorded. The log of a disturbed sample boring should contain all applicable information as discussed in Chapter 13 and in paragraph 6-6 for undisturbed samples.

8-4. Preservation and Shipment of Samples

Disturbed samples should be handled and preserved to prevent contamination by foreign material and to ensure that the in situ water content is preserved, if necessary. Each specimen should be representative of the in situ soil at the depth from which the sample was taken. Stratification should be preserved, if possible. For specific cases, soil samples should be protected from temperature extremes during shipment and storage. Additional guidance for preservation and shipment of samples is provided in Chapter 13 and ASTM D 4220-83 (ASTM 1993).

a. Containers. If the water content of the sample is to be preserved, the sample should be sealed in a glass jar or other suitable container. Large-volume representative samples may be placed in tightly woven cloth bags and tied securely to prevent contamination and loss of sample. If samples are to be stored for an extended time, the soil should be placed in plastic-lined cloth bags as soil moisture will cause the cloth bags to deteriorate. In general, metal containers should not be used if samples are to be stored, as the container will tend to rust or corrode and may contaminate the sample.

b. Sealing. Samples for water content determination must be sealed to prevent changes of soil moisture. If glass jars are used, the gasket and the sealing edge of the container must be clean to ensure a good seal.

c. Identification. All soil samples must be properly marked to accurately identify the origin of the sample. A completed ENG Form 1742 and/or 1743 (see Figure 13-1) should be securely fastened to each sample. A second tag should be placed in a waterproof envelope inside the sample bag; this tag will aid in sample identification in case the outer tag is lost. All markings should be made with waterproof, nonfading ink.

d. Packing for shipment. In general, disturbed samples do not require special shipping precautions. However, the sample containers should be protected from breakage and exposure to excessive moisture which may cause deterioration of the labels and/or cloth bags. Glass jars usually can be packed in the cartons furnished by the manufacturer. If the transportation requires considerable handling, the cartons should be placed in wooden boxes. Double bags should be used if the bag samples are expected to receive considerable handling.

e. Methods of shipment. The most satisfactory method of sample shipment is in a vehicle that can be loaded at the exploration site and driven directly to the testing laboratory. This method helps to minimize sample handling and allows the responsibility of transporting the samples to be delegated to one person. Samples shipped by commercial transportation companies require special packing or crating, special markings, and instructions to ensure careful handling and minimum exposure to excessive heat, cold, or moisture.

Chapter F-9 Sampling Frozen Soils

9-1. Introduction

Drilling and sampling in frozen ground is somewhat similar to performing the same operations in rock. Sellman and Brockett (1987) reported experiences of drilling in a range of geotechnical materials. For finer grained materials, such as silt, clay, organic material, and ice, at a few degrees below freezing, they reported that the materials were ductile and tough and needed to be cut like plastic or metal. They also reported that unfrozen water was sometimes present at the grain boundaries. As the in situ temperature decreased, the materials became stronger and more brittle and drilled like chemically cemented or crystalline rock. For coarser-grained frozen soils, such as coarse sands and gravels, Sellman and Brockett reported that drilling was similar to drilling in concrete. Likewise, the U.S. Army Corps of Engineers, Kansas City District (1986) reported that drillers had described drilling in frozen sand as “much like drilling sandstone.”

Sellman and Brockett (1987) reported that much of the off-the-shelf drilling equipment could be used for drilling frozen soils. Diamond or tungsten drill bits with only minor modifications to the drill rig, fluid circulating system, and drilling tools could be used. However, they warned that some drill bits did not perform as well in frozen soils as in unfrozen soils. As rule of thumb, Sellman and Brockett suggested that if the bit performed well in frozen soil, it would also perform well in unfrozen soil; however, the reverse condition was not always true.

The equipment and procedures for drilling frozen soils include the use of a drill bit suited to drilling the frozen soil, equipment to chill the drilling fluid to a temperature which is equivalent to or slightly less than the temperature of the frozen formation, equipment for transport and storage of the frozen samples, and perhaps, equipment to obtain samples which are slightly larger in diameter than conventional unfrozen samples. For example, larger fluid ports in the drill bit may be needed to permit the ice cuttings to be transported without clogging the bit. If drilling fluid is used, it should be cooled to the in situ temperature to minimize the thermal shock to the formation. Lange (1963) suggested that the temperature of the drilling fluid should be within ± 1 deg C (± 2 deg F) of the in situ temperature of the formation. Oversized samples would permit the periphery of the sample to be trimmed prior to testing if a slight amount of thawing occurred during the sampling and handling processes. Furthermore, the larger diameter samples would be less fragile than the smaller diameter samples and therefore would be less likely to be broken during the sampling and handling processes. Related information is presented in Appendix D: “Artificial Ground Freezing for Undisturbed Sampling of Cohesionless Soils.”

With respect to the strength of frozen soil, the strength would tend to increase as the temperature was decreased or as the ice content was increased. With other factors held constant, the torsional strength of a sample would increase as the diameter of the sample was increased. As compared to drilling and sampling unfrozen soils and rocks, the time required to complete each borehole would be governed by material type, equipment condition, proficiency of the operator, core retrieval efficiency, etc. Good coring practices and procedures should be followed, regardless of whether the material is sampled in a frozen or an unfrozen state.

9-2. Drilling Equipment

The principal decisions for drilling and sampling in frozen soils include the selection of suitable drilling equipment, a method of advancing and stabilizing the borehole, drilling fluid, and a refrigeration unit to cool the drilling fluid and drill string to a temperature equivalent to or slightly less than the temperature of the in situ formation. The drill bit and the refrigeration unit are probably the two pieces of equipment which will have the greatest influence on the success of drilling operations in frozen ground. A discussion of the equipment follows.

a. Drill bit. When the drill bit is selected, a number of factors regarding its design should be considered. The drill bit should be designed to resist impact loading on the cutting teeth and the abrasive action of the soil cuttings on the teeth and matrix of the bit. It should be designed for full face cutting. If a full cut design is not utilized, the uncut ribs of frozen soil will rub against the bit body and slow the drilling process. Penetration of the bit beyond the uncut ribs can be accomplished only by frictional melting and abrasion of the uncut ribs. The flow paths for the cuttings should not be obstructed. Drilling in frozen soils may cause the cuttings to stick together and refreeze. These cuttings could plug the flow paths for the drilling fluid and render it ineffective for transporting the cuttings to the surface. If an obstruction of the flow paths occurred, cuttings could collect in the annulus above the drill bit or on the walls of the borehole and cause the bit to become lodged in the borehole.

(1) *Cutting teeth.* The drilling characteristics of frozen soils vary according to grain size, ice content, and temperature of the material. In general, the material tends to become stronger and more brittle as the temperature becomes colder, although the frozen strength is usually much less than the strength of chemically cemented rock or crystalline rock. Under the action of the drill bit, the frozen material tends to crack and crumble. The characteristics of bits for drilling in frozen sediments are frequently not found in commercial bits which have been designed for use in unfrozen soils and rocks. Frequently, excessive thrust and torque are used. As a result, poor cores are produced, poor drilling rates are experienced, and excessive wear on equipment often occurs. For frozen, coarse sands and gravels, diamond drill bits have been used with limited success, provided that the matrix or ice is frozen solidly. However, diamond bits are not well suited to drilling frozen fine-grained soils and ice at a few degrees below freezing. Likewise, percussion and roller rock bits are generally ineffective. The cutter teeth on most commercially available drag bits do not cut the whole face but merely dig furrows in the frozen material. This problem occurs because there is no overbreak of the material and the drill bits have not been designed to ensure a full coverage of the surface being drilled by the cutter teeth.

Chisel-edge, wedge-shaped, finger-style cutters, such as the Hawthorne bit for drilling or sawtooth bits for coring, work well in fine-grained frozen soils, provided there is overlap of the cutting surfaces. Teeth made of tungsten carbide provide a durable cutting surface. The grade of carbon in the tungsten carbide bit should be chosen to optimize abrasion resistance and impact resistance of the cutting teeth. This finger-style cutter is advantageous because the individual fingers can be easily sharpened or rapidly replaced. When a finger-style bit is used, the shape and orientation of the cutting wedges influence the efficiency and stability of the bit. The internal angle of the wedge and the angle at which it is attached to the drill bit determine its orientation. Figure 9-1 may aid the discussion of the shape and orientation of the cutting tooth.

The rake angle, $\hat{\alpha}_1$, is the most important angle of the cutting tooth. It is the slope of the front face of the advancing wedge and is measured from vertical. As the positive rake is increased, cutting becomes easier. If the rake angle is zero, the drill cannot penetrate the formation easily. With a negative rake, thrust and torque must be increased to advance the borehole. Additionally, a negative rake could tend to cause the drill bit or drill rods to unscrew if reverse rotation is used to free a lodged bit.

The sharpness of the cutting tooth determines the efficiency of the drill bit. A measure of the overall sharpness of the wedge is expressed as the included angle, β_3 . This angle is usually fixed. It must be large enough to resist breakage and hold a sharp edge. Typically, 30 to 40 deg is reasonable for drilling most hard materials.

The relief angle, β_2 , is the slope of the underside of the tooth. It is measured from horizontal and is automatically determined for a specific cutting tooth when the rake angle is specified. The relief angle governs the rate of penetration for any specific rotation speed.

The rake angle, β_1 , or the relief angle, β_2 , may be defined as apparent angles or as actual angles, depending on the reference criteria. Apparent angles are defined with reference to the axis of the drill and are constant, regardless of the drilling conditions. Actual angles are defined with reference to the helical penetration path. Actual angles vary with the drilling conditions, including the penetration rate, rotation speed, and the radius of the boring head.

The apparent relief angle governs the rate of penetration. When the actual relief angle is reduced to zero, i.e., the helical angle of the penetration path is equal to the apparent relief angle, the rate of penetration reaches a maximum value. Hence, the maximum penetration rate for a given bit design and a specific rotation speed can be calculated. Likewise, the minimum apparent relief angle for any position on the cutting head can be calculated if the desired penetration rate and the rotation speed are given. From a practical standpoint however, the efficiency of the cutting action near the center of the bit is relatively low because the penetration rate is high as compared to the rotation speed. Thus, the center of the bit may either be fitted with a sharp spear point that indents and reams the center of the borehole or an annulus that cores a small-diameter core. If the latter method is used, the core tends to shear when the length to diameter becomes excessive.

The cutting wedges can also be designed for a specific direction of cutting. For oblique cutting, the cutting edge aids in the lateral transport of soil cuttings. During orthogonal cutting, the cutting edge travels at right angles to the tangential travel direction. The direction of cutting is important for removal of cuttings from the face of the bit. The direction of cutting, along with the location of fluid ports, should be considered when a finger-type bit is designed or selected.

Each cutting tooth should be designed for a specific location on the bit. For example, the relief angle, rake angle, and orientation of a cutting tooth located near the center of the bit may be much different than the comparable placement of a cutting tooth located near the edge of the bit. It should also be noted that although a drill bit may be designed and/or selected for a specific drilling operation or condition, wearing on the underside of the tool by the action of the cuttings may affect the efficiency of the drill bit. Periodic inspections of the drill bit and cutting surfaces should be made, and repairs or replacement of the cutting teeth or drill bit should be made as necessary.

(2) *Stability of the drill bit.* The lack of stability can cause vibrations and shuddering of the drill string. These factors, in turn, make drilling a straight hole difficult. The stability and smooth rotation of the drill bit is influenced by a number of variables which include the symmetry of the cutter placement, the number of cutters, the stability of drive unit, and the diameter of the borehole as compared to the bit body or auger diameter. A step configuration of the cutting teeth, as illustrated in Figure 9-2, tends to stabilize the bit in the borehole as well as enhancing its cutting efficiency.

b. *Augers.* All of the basic drilling operations, including penetration, material removal, and wall stabilization, are satisfied when drilling with augers. Furthermore, a minimum amount of hardware and

equipment is required. The principal disadvantage of an auger for drilling and sampling in frozen formations is that the ambient air temperature must be lower than -2 to -4 deg C (26 to 28 deg F). If higher air temperatures are encountered, heat from the warm air will be transferred down the stem of the auger. Furthermore, heat is created as a result of friction between the soil and auger. The effect could include thawing of the pore water and deterioration of cores and walls of the borehole.

Bucket augers or hollow-stem or solid-stem augers can be used. With bucket augers or short-flight augers, the borehole can be advanced by lowering the auger in the hole and rotating. After the bucket or auger flights are filled with cuttings, the auger is withdrawn from the borehole to remove the cuttings. The auger also must be removed from the borehole before a core can be obtained. If a continuous-flight auger is used, the cuttings are carried to the surface on the auger flights. With the hollow-stem auger, a sample can be obtained by lowering a specially designed core barrel through the hollow stem to obtain a sample of soil, rock, or ice or by using the auger to cut a core of material. Sampling through a hollow-stem auger is discussed in Chapters 5 and 6. A brief description of the U.S. Army Engineer Cold Regions Research and Engineering Laboratory (CRREL) hollow-stem coring auger (Ueda, Sellman, and Abele 1975) is discussed below.

The original coring auger, known as the CRREL 3-in. (76-mm) coring auger, was the standard tool for shallow depth coring in frozen materials for three decades. The auger consisted of a section of tubing wrapped with auger flights. A cutting shoe was affixed to one end of the hollow tube, and a drive head was attached to the other end. The overall length of the barrel with the cutting shoe and driving head attached was approximately 1.0 m (3.3 ft). The cutting shoe was equipped with two chisel-edged cutting teeth. The chisel-shaped teeth were designed with a 30-deg rake angle, a 40-deg included angle, and a 20-deg relief angle. Elevating screws which were attached to the cutting shoe were used to control the effective relief angle. Cuttings were fed onto two helical auger flights. The pitch of the auger flights was 20 cm (8 in.) and the helix angle was 30 deg. During the coring operations, the cuttings were carried upward on the auger flights and allowed to pass through holes in the hollow tube and to accumulate above the core. Cuttings were not permitted to accumulate above the drive head because of the tendency to jam the sampling apparatus in the borehole. The cuttings which had accumulated above the core wedged between the core and the barrel wall during the sampling operation; this action helped to retain the sample in the coring auger. Unfortunately, it is also believed that the material that had been wedged between the core and the walls of the tube also applied torque to the core which caused the core to break into short lengths.

The Rand auger, which replaced the CRREL coring auger, was designed to obtain a core approximately 108 mm (4-1/4 in.) in diameter by 1.4 m (4.6 ft) in length. The cutting shoe was equipped with two chisel-edged cutting teeth which were affixed onto 45-deg helical slots. The teeth were designed with a 45-deg rake angle, a 30-deg included angle, and a 15-deg relief angle. Elevating screws were used to control the effective relief angle. Cuttings were fed onto two helical-auger flights. The pitch of the flights was 20 cm (8 in.) and helix angle was 25 deg. In addition to the minor changes to the Rand auger as compared to the CRREL coring auger, the significant modifications to the coring auger need to be addressed. First, holes were no longer placed in the walls of the hollow tube. The cuttings are carried on the auger flights to the top of the drive head. For the standard Rand auger, the drive cap is not solid and some cuttings may fall into the hollow tube and onto the top of the core. However, a solid drive cap can be used, if desired. To retain the core in the sample tube, the cutting shoe was fitted with spring-loaded wedges which clamped onto the periphery of the sample after the drive was completed. This clamping action helped to shear the core from the formation and retain it in the tube as the auger was removed from the borehole. For deep coring drives, a section of solid-stem flight auger can be attached to the top of the coring auger to retain the cuttings. The addition of auger flights to the top of the coring auger helps to

reduce the potential for jamming the apparatus in the borehole during retraction from a deep drive. To stabilize the drill rod on long coring runs, centering disks can be used on the drill rod at 1- to 2 m (3- to 6 ft) intervals.

c. Drilling fluids, fluid pumps, and refrigeration units.

(1) *Drilling fluids.* The circulation of drilling fluid at an acceptable temperature, adequate pressure, and rate of flow is extremely important when drilling frozen soils. If the temperature of the drilling fluid or equipment is higher than the temperature of the formation, pore ice could begin to melt. If cuttings are produced more rapidly than they are removed, they may be reground by the bit. This condition would tend to slow the drilling rate. Cuttings which are not efficiently removed from the borehole tend to stick together or to the walls of the borehole and refreeze. As a result, the drilling equipment could become lodged in the borehole.

A variety of chilled fluids have been used in the drilling of frozen soils, including diesel fuel, water-based fluids such as brine and mixtures of propylene glycol or ethylene glycol and water, and compressed air. Although a comprehensive discussion of commonly used drilling fluids for soils and rocks is presented in Chapter 4, a few comments on the use of chilled drilling fluids are needed.

(a) *Diesel fuel.* A liquid drilling fluid is more viscous than air. This characteristic tends to dampen mechanical shocks and vibrations which are caused by the action of the bit and core barrel to the core or formation. When a liquid as compared to compressed air is used as the drilling fluid, the pressure at the bottom of the borehole is not abruptly altered when drilling is ceased. Furthermore, the hydrostatic head at the bottom of the borehole is similar to the in situ condition.

Arctic-grade diesel fuel may be the best drilling fluid used to drill frozen soils, rocks, and ice. Unfortunately, diesel fuel is not an environmentally acceptable drilling fluid. Diesel fuel tends to contaminate the core. It may also change the freezing point of water in the soil pores. As a result, the pore ice in the core and the walls of the borehole may begin to deteriorate during the drilling process. Other disadvantages include: a large quantity of diesel fuel is needed; protective clothing and gloves should be used; and the potential for fire is increased.

(b) *Water-based fluids.* Water-based drilling fluids, such as mixtures of two to four percent by weight of salt to water (Hvorslev and Goode 1960) or two parts of water to one part of propylene glycol or ethylene glycol, by volume (U.S. Army Corps of Engineers, Kansas City District 1986), offer many of the same advantages and disadvantages of using diesel fuel. Water-based drilling fluids reduce the vibrations and mechanical shocks to the formation caused by the drilling operations as well as stabilize and balance the in situ stresses in the borehole. Liquid drilling fluids are much more efficient than compressed air for cooling the bit and transporting the cuttings away from the drill bit and to the ground surface. However, there is the ever present possibility that the core may be contaminated by the drilling fluid which may alter the temperature required to keep the pore water frozen. As in the case for diesel fuel, the pore ice in the core and on the walls of the boring could thaw and cause deterioration of the structure. Protective clothing, gloves, and other safety items should be worn because of the potential health concerns caused by the exposure of the skin and other organs to concentrations of salt or other chemicals in the drilling fluid.

(c) *Compressed air.* Compressed air does not exchange heat as efficiently, nor is it as effective for removing cuttings from the borehole as liquid drilling fluids. However, the use of compressed air for drilling frozen formations is environmentally more acceptable than are the other liquid drilling fluids.

When drilling frozen formations including ice-saturated fine-grained soils and ice, the requirements of chilled compressed air may be somewhat different than for drilling frozen or unfrozen coarse-grained materials. When frozen formations are drilled, the temperature and the flow rate or return velocity of the compressed air should be monitored and adjusted as necessary. The temperature of compressed air may increase because of friction as it is pumped through the drill string and returned to the surface. The temperature of the return air should be slightly lower than the temperature of the formation being drilled. The required upward annular velocity is a function of the size of the cuttings, the drill bit, and the formation and should be adjusted as necessary. For example, Lange (1973a) reported that compressed air delivered at 600 standard cubic feet per minute (scfm)¹ at 110 psi was satisfactory for drilling frozen gravel. From the data which were given in Lange's report, the upward annular velocity was calculated as 20 m/sec (4,000 ft/min). Diamond impregnated and surface-set diamond bits were used. For drilling ice, Lange (1973b) reported that an uphole velocity of 8 m/sec (1,500 ft/min) was satisfactory. Finger-type ice coring bits were used. From this information, it is apparent that there is no "cookbook" answer on the correct flow rate for drilling with air. Depending on the drilling conditions, materials, and equipment, a range of compressed air requirements could be required. It is suggested that a range of flow rates should be investigated and the optimum condition should be utilized.

(2) *Fluid pumps and air compressors.*

(a) *Fluid pumps.* A progressive cavity-type pump or a positive displacement piston pump can be used for circulating a liquid drilling fluid. Precautions should include a routine inspection of the circulation system for accumulation of cuttings. If excessive cuttings are cycled through the system or accumulate along the baffles of the mud pit, the length of travel of the mud may have to be increased to allow sufficient time for the cuttings to settle before the drilling mud is recycled. The use of desanders should also be considered.

(b) *Air compressors.* The air compressor must have adequate capacity to obtain a sufficient uphole velocity to carry the cuttings to the surface. In Chapter 4, it was reported that the effective use of air as a drilling fluid required a high volume of air to efficiently remove the cuttings from the borehole. High pressure alone would not assure a sufficient volume of air. Furthermore, excessively high air pressure could damage the formation or cause other drilling problems. An uphole velocity on the order of 20 to 25 m/sec (4,000 to 5,000 ft/min) was suggested for many drilling conditions. As a matter of precaution when frozen formations are drilled with air, a routine inspection of the core barrel and bit should be conducted for constrictions of airflow, such as frozen cuttings collecting at these orifices. A sludge barrel should also be used to collect particles which are too heavy to be lifted by the flow of compressed air or if the air pressure suddenly failed.

(3) *Refrigeration units.* During drilling operations, heat is generated by the mechanical cutting of the frozen formation. Other sources of internal and external heat energies include the ambient air temperature and the frictional heating of the drilling fluid as it is compressed and/or pumped through the drill system. To minimize the thermal disturbance of the borehole wall and core, the drilling fluid, albeit liquid or gas, must be continually cooled. This cooling can be accomplished by circulating the drilling fluid through a chiller attached parallel to the coolant system.

¹ The *McGraw-Hill Encyclopedia of Science and Technology* (McGraw-Hill, Inc. 1992) states that standard air is 20 deg C (68 deg F), 101.3 kPa (14.7 psi), and 36 percent relative humidity; gas industries usually consider an air temperature of 15.6 deg C (60 deg F) as standard.

There are no unique designs of a refrigerator plant. Generally speaking, the design of the refrigeration system can be obtained from data from compressor manufacturers handbooks, although the assistance of an engineer or technician from a refrigeration company may enhance the cost-effectiveness of the design of the system. The requirements for the system will vary according to the specific site conditions. Factors such as the type of drilling fluid, the temperature of the subsurface material, and the ambient air temperature may affect the design of the system. The cooling capacity of the refrigerator plant should be compatible with the flow rate and pressure of drilling fluid as dictated by the drilling rig and the drilling fluid pump.

The refrigeration system generally consists of a freon compressor which is used to chill a fluid, such as ethylene glycol. The drilling fluid is circulated through a heat exchanger to cool it. If compressed air is used, the heat exchanger may be similar to the radiator on an automobile or may consist of chilling coils in a pressure vessel. If a liquid drilling fluid is used, chilled ethylene glycol may be pumped through chilling coils in the mud pit or through chilling coils in a pressure vessel. When the heat exchanger system is selected, consideration should be given to the method for defrosting the system, especially when the drilling and sampling operations are conducted in a humid environment in which the ambient temperatures are anticipated to be greater than approximately -7 deg C (20 deg F). Lange (1973b) reported that it was more difficult to defrost a liquid to compressed air heat exchanger than to defrost an air to air heat exchanger. Consequently, the type of heat exchanger and the ease of defrosting it could influence the selection of the refrigeration system and/or the drilling fluid.

d. Other equipment. Drilling in frozen formations may require other special pieces of equipment. Split-ring or basket-type core lifters will likely retain core satisfactorily for most sampling operations. For deep boreholes, a drill collar (Lange, 1973b) may be used to shift the point of tension and compression in the drill string; the use of this equipment will reduce the downward pressure on the formation. Rod stabilizers (Brockett and Lawson 1985) are useful for minimizing the potential for eccentric drilling which can cause oval boreholes or cores. Sludge barrels can be placed above the core barrel when drilling with compressed air. This equipment is useful for capturing particles which are too heavy to be lifted by air pressure; it can also be used to capture the cuttings suspended in the borehole in case the air compressor suddenly failed. Additionally, the sludge barrel would minimize the potential for cuttings falling on top of the drill bit and refreezing and/or wedging it in the borehole. It is noteworthy that a sludge barrel is often affixed to the top of an auger specifically to capture the cuttings. Lastly, it may be necessary to artificially freeze an in situ formation of cohesionless soils to obtain high quality undisturbed samples. Special equipment and recommended procedures to artificially freeze an in situ formation are discussed in Appendix D.

9-3. Drilling and Sampling in Frozen Soil and Ice

The procedures for drilling and sampling in frozen ground are similar to the procedures which are used for unfrozen ground that are reported in Chapter 6. The principal differences include selecting the drilling equipment and drilling fluids, chilling the fluid and equipment, removing the cuttings from the borehole, and providing freezers or some other suitable method for storage of the frozen core. A suggested procedure is presented in the following paragraphs.

Casing may be used to stabilize unfrozen soil or water at the earth's surface or as a casing collar in frozen soil. To set the casing in frozen soil, drill a pilot hole about 1 m (3 ft) deep with a suitable drill bit. Place a 1.5 m (5 ft) long section of casing in the borehole, drive the casing to firm frozen soil, and then remove the soil from inside the casing. After the casing has been set, place the slush pit over the borehole, align the collar of the slush pit with the casing, and place packing in the joint between the

casing and the collar of the slush pit. If unfrozen soil or water are encountered, the procedures for setting casing are similar to the procedures for setting casing in frozen soil. However, the depth to stable soil, and hence the depth at which the casing must be placed, may be much greater than the depth required for frozen soil.

a. Advancing the borehole.

(1) *Augering.* The procedures for using augers to advance boreholes in frozen soil or ice are similar to those which are suggested in Chapter 6. However, as with any drilling or sampling procedures, the driller may modify the recommended procedures as required to enhance the drilling and sampling operations for the particular site conditions.

(2) *Rotary drilling.* Rotary drilling in frozen soils is not much different from the procedures and operations which are reported in Chapters 6 and 8 for drilling unfrozen soils. In addition to the requirement for keeping the formation frozen by using chilled drilling fluid and drilling equipment, the primary differences for drilling in frozen soils as compared to unfrozen soils include the use of a slush pit with more baffles to allow sufficient time for the cuttings to settle, additives to adjust the viscosity and specific gravity of drilling fluid, and in some cases, the use of casing for near surface conditions when peat or large volumes of unfrozen water are encountered. Other factors which must be considered include the ambient air temperature and the weather conditions, the in situ formation temperatures, and the effects of thawing on the behavior of the material.

In general, rapid penetration at high rates of revolution of the bit with low pressures and low volumes of fluid circulation is recommended for most soils. Experience has shown that slower rates of penetration have resulted in increased erosion and thawing of the walls of the borehole because of the drilling fluid. The type of drilling fluid also needs careful consideration. Chilled air cannot remove frictional heat from the drill bit as efficiently as liquid drilling fluids. Chilled brine, ethylene glycol, or diesel fuel may be environmentally unacceptable. These drilling fluids may also change the freezing point of water in the soil pores and thus cause thawing of the formation. When casing is needed, the liquid drilling fluids may be undesirable because of the need to freeze the zone between the casing and soil.

Finger-type tungsten drag bits have been used for advancing boreholes in frozen formations. In general, the results were good except the cuttings tended to collect in the borehole and thus inhibited the cooling effects of the drilling fluid. Ice-rich silt and ice-rich sand were easily drilled and cored, although sand tended to dull the cutting surfaces more rapidly than silt. Ice-poor sand was easier to core than ice-poor silt or ice-poor clay. Dry frozen silt or silty clay was fairly difficult to drill as the cuttings tended to ball and refreeze on the walls of the borehole. The result was sticking and freezing of the bit or core barrel when its rotation was stopped. Gravelly soils tended to damage the carbide cutting tips. When ice formations are drilled, the downward pressure of the drill bit must be minimized. The reduction of pressure on the drill bit can be accomplished by the use of a drill collar which shifts the point of tension and compression in the drill string.

b. Sampling.

(1) *Sampling with Augers.* If sampling is conducted in conjunction with augering, the procedures will be dictated by the type of samples to be obtained. Disturbed samples cannot be obtained from the cuttings which have been carried to the surface by the auger flights; these cuttings may be mixed with materials from various depths and therefore may not be representative of the formation(s) of interest. Cores of frozen material can be obtained by the hollow-stem auger sampler, as described in paragraphs

5-1c and 6-4c, or the center bit can be removed and the barrel of the hollow-stem auger can be used as casing for sampling with core barrel samplers. It should be noted that the hollow-stem auger could freeze in the borehole during the sampling operations. Therefore, this method should be used cautiously.

The coring run consists of augering the barrel into the formation until it is filled with cuttings and core. During this operation, the depth of penetration should be monitored as an excessive drive will damage the core. However, it has been reported that when ice is cored, cuttings were purposely wedged between the core and core barrel. This action enhanced the breaking of the ice core at its base and recovering the sample. This procedure is not recommended for soil sampling operations.

Several precautions for sample coring with augers are offered. All trips up and down the borehole should be made without rotation. Select the proper bit for the formation to be drilled. Bits which are improperly matched with the formation may result in coarse cuttings which would tend to collect on the top of the core barrel. During withdrawal, the cuttings would compact and could cause the device to jam in the borehole. If the device becomes frozen in the borehole, the freezing point of the pore water in the cuttings must be lowered to free the apparatus. Cuttings can be thawed by brine solutions, antifreeze solutions, or jetting air past the cuttings. However, these operations may also cause the walls of the borehole to thaw.

(2) *Sampling with core barrel samplers.* The equipment and procedures for sampling frozen soils are similar to the equipment and operations which are reported in Chapters 5 through 8 for sampling unfrozen soils. Standard double-tube core barrels equipped with tungsten coring bits and basket-type or split-ring core lifters have been used for sampling frozen cohesive and cohesionless soils.

9-4. Special Considerations

A number of considerations are noteworthy when drilling operations are conducted in frozen formations. However, the two most important considerations are the selection of the drilling fluid and the drill bit. A brief discussion follows.

The type of drilling fluid should be selected after the benefits and limitations of each are considered. At high ambient temperatures, compressed air will not cool the drilling equipment sufficiently. As a result, the in situ formations may tend to thaw. At ambient temperatures less than about -4 deg C (25 deg F), compressed air works well although the defrosting problems for chilling air by mechanical refrigeration is difficult. Liquid drilling fluids, such as diesel fuel, ethylene glycol, and brines, have a greater capacity for heat exchange than compressed air. However, these fluids may tend to alter the freezing point of the in situ material as well as contaminate the formation and the sample cores. Furthermore, the liquid drilling fluids may have an adverse effect on the drilling equipment, i.e., the salt in a brine tends to deteriorate drilling equipment, or diesel fuel may dissolve or dilute the grease used to lubricate the drilling equipment.

The drill bits and rate of advancement should be selected according to the material in the formation. The drill bit should employ full-face cutting of the formation. Uncut ribs rub against the bit body and slow drilling and/or stop penetration. If the cutting surfaces of the bit are incorrectly positioned, an irregular and scored surface of the core may result. If the rate of penetration is too aggressive, the core may break or the fluid ports in the drill bit or core barrel may become clogged frequently. If the rate of drilling is too slow or if the cutting of the bit is ineffective, small chips or frictional melting and refreezing of the core could occur. The stability and smooth running of the drill bit is influenced by symmetry of cutter placement, the number of cutters, the stability of drive unit, and the diameter of the borehole as compared

to the bit body or auger diameter. The lack of stability can cause vibrations and shuddering of the drill string which would make the drilling of straight holes difficult to impossible.

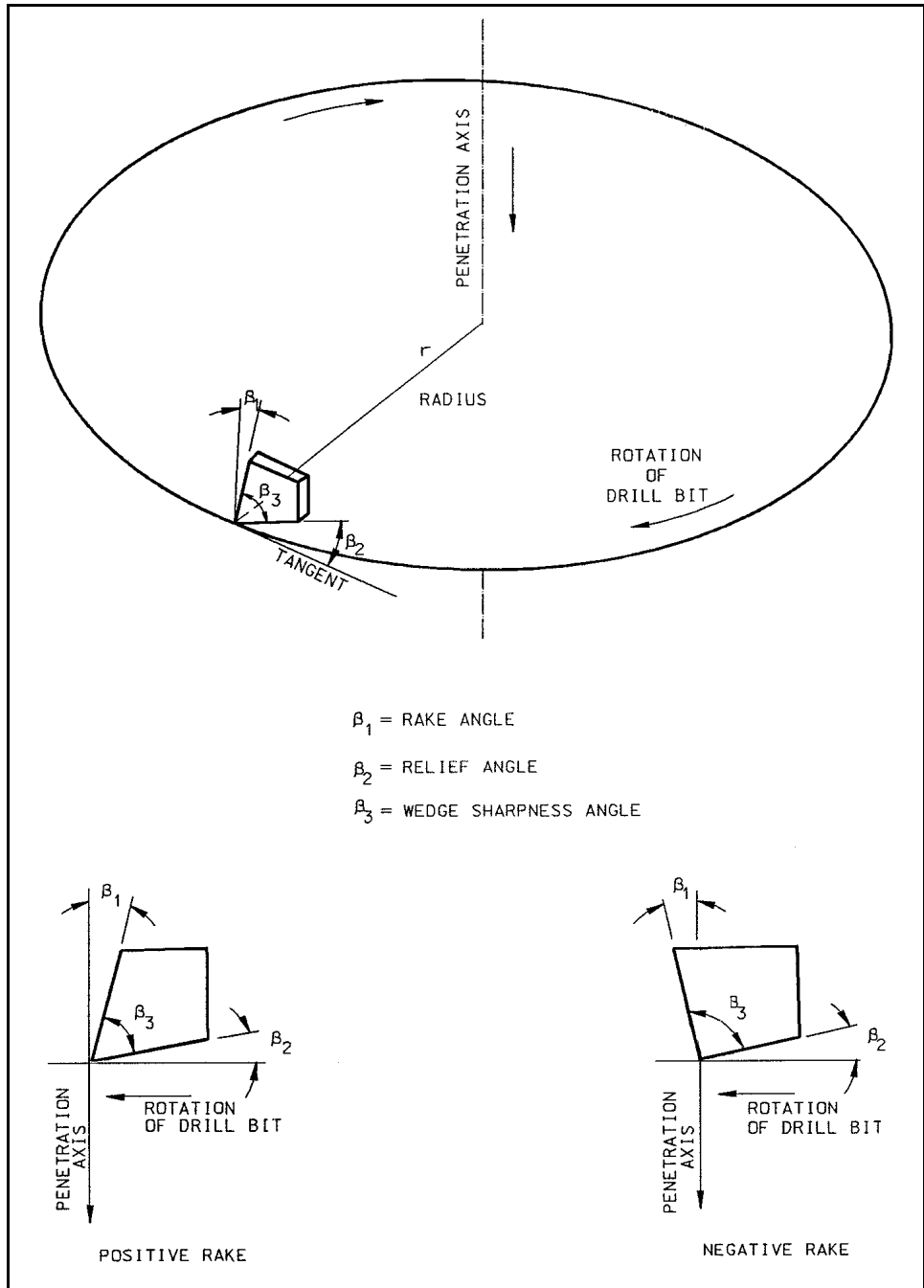

Figure 9-1. Schematic of a cutting tooth which defines the shape and orientation of the tooth (after Mellor 1976)

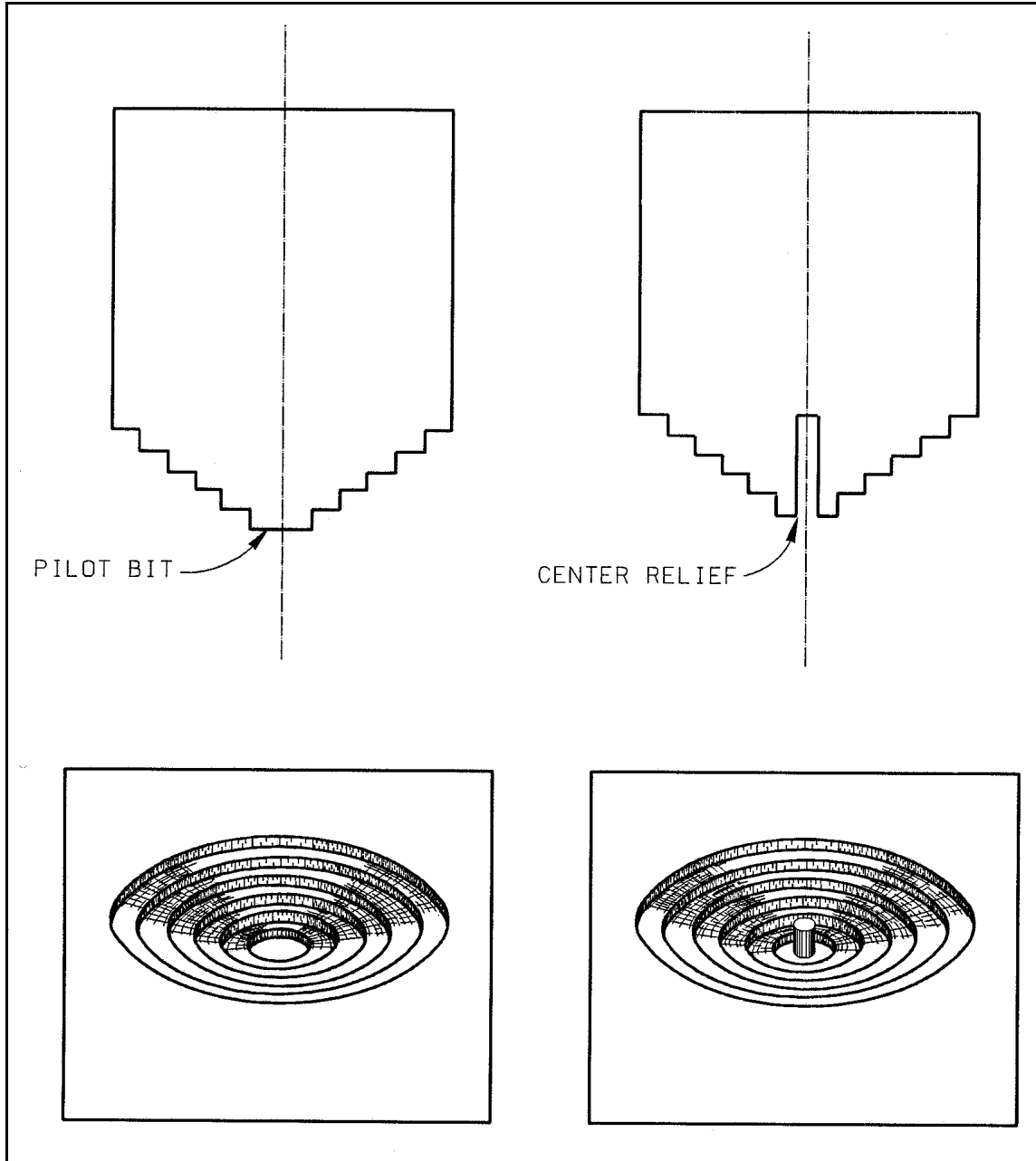

Figure 9-2. Schematic of the step configuration of the cutting teeth on a drill bit and an isometric drawing of the cut surface at the bottom of the borehole

Chapter F-10 Underwater Sampling of Soils

10-1. Introduction

This chapter is intended to provide guidance for obtaining soil samples in the nearshore environment, such as harbors, rivers, coastal plains, backswamps, and wetlands where the depth of water varies from 0 to 45 m (0 to 150 ft), and is generally less than 20 m (65 ft). Sampling in deep water is not addressed herein. This guidance is intended to support typical projects such as marine construction projects, dredging of channels and harbors, construction of levees and dams, and reclamation of wetlands. Therefore, the information concentrates on common, commercially available sampling equipment and methods. One-of-a-kind research tools or equipment available only from foreign countries is not discussed. Appendix A lists references that discuss some of these topics. However, guidance for obtaining chemical samples, which is typically done in conjunction with soil sampling, is beyond the scope of this manual. Geotechnical personnel should coordinate underwater chemical sampling with the Project Environmental Engineer, or should refer to EPA Manual 503/8-91 (the “green book”) and the appropriate Regional Implementation Manual.

Generally, sampling soils underwater in the nearshore environment is not significantly different from sampling soils on land. The concerns for obtaining minimally disturbed samples for geotechnical testing are the same; the samples are just more difficult to obtain. In addition to the need to find the right equipment for obtaining samples, a work platform or vessel and a positioning system are needed. The wind, waves, tides, currents, and water depths must also be considered when planning a site investigation.

The selection of appropriate sampling equipment for retrieving underwater samples depends upon several factors: soil data required, sizes of test specimens needed, sediment type, geology, the depth of water or elevation of the seafloor, environmental conditions, vessel availability, and funding limits. These factors do not always favor selections that are compatible. For example, the equipment required to obtain the size and/or quality of sample(s) may not be deployable from the vessel available within the project budget, or the available vessel may not be able to operate in the required shallow-water depths. Each of these factors will be discussed in this chapter.

10-2. Underwater Sediment Types

The selection of appropriate equipment for underwater sampling depends on the type of sediment to be sampled. Because some samplers cannot be used to retrieve a high-quality sample, or in some cases, any sample in certain types of materials, it is important to know beforehand the types of sediments most likely to be encountered at the site.

Marine sediments can be classified according to several criteria (Noorany 1989). In the nearshore environment, marine sediments are classified according to their origin. Lithogenous (derived from rock) sediments are formed from terrestrial or volcanic sources. Underwater lithogenous (terrigenous) sediments result either from a rise in the sea level, the submergence of land due to geological events, or by soil particles being transported by wind, water, or ice to the sea where they settle. Because sampling terrigenous sediments is similar to sampling the same types of soils on land, determination of the source of the sediments and the method by which the deposit was formed can help in predicting whether the sediment is normally consolidated or overconsolidated; this information can be used as a guide for

selecting the best sampling method(s). Biogenic sediments, which are found in both nearshore and deep ocean deposits, are formed from the remains of marine organisms. The most common sediments are either silica (SiO₂) or calcium carbonate (CaCO₃) materials. Hydrogenic sediments are formed by a chemical reaction that occurs under the right conditions of temperature, pressure (water depth), and chemical content of the water and subsequent precipitation of material. Hydrogenous deposits of calcium carbonate can be found nearshore in some areas. Unlike the terrigenous sediments, calcium carbonate sediments are particularly difficult to sample without disturbance; additional information is contained in the proceedings of the international conference on calcareous sediments (Jewell and Khorshid 1988).

10-3. Planning an Underwater Site Investigation

Planning a site investigation on land is discussed in Chapter 2. As compared to an onshore investigation, a nearshore or offshore investigation may encounter some unique problems. To plan an effective offshore investigation, preliminary information should be gathered on the site configuration, environmental conditions, the type of sediment expected to be found at the site, and the sampling equipment and work platforms available and their capabilities. With this information, decisions can be made regarding where to take samples, how many, and to what depth to meet the project requirements. Information on the expected sediment type and the data needed from the samples will determine the type of sampler to use.

One of the first steps is to obtain a marine chart of the area to be surveyed. Suitable charts and maps are available from the National Ocean Service and the National Oceanic and Atmospheric Administration (NOAA) for coastal and Great Lakes areas, the Defense Mapping Agency for open ocean and foreign waters, and the U.S. Army Corps of Engineers for inland rivers, lakes, and canal systems; these documents can be purchased at local marine chandlery stores or ordered from the issuing agency. If the survey site is close to shore, a topographic map of the adjacent land area may also be very helpful. Marine charts normally will show sediment types, water depths, shipping channels, permanent moorings, bridges, buoys, shoals, underwater cables and pipelines, and other items of interest. Water depths are usually referenced to low-water level, whereas bridge clearances are referenced to high-water levels. The date of the chart should be checked and the information on it verified and/or adjusted according to its age. For example, water depths in a harbor may be less than indicated due to sedimentation.

Prior to the investigation, it is suggested that a site visit should be conducted, if possible, to compare the chart with the actual site conditions. Moorings, piers, or other shoreline construction can affect the planning of the survey. While at the site, obtain boat traffic patterns, weather conditions, typical wave heights and currents, and other conditions which could affect the survey. The impact of seasonal events, such as sport boating or fishing seasons, and changes in environmental patterns, such as the deposition and erosion of sediments, weather patterns, or the occurrence of fog, should be investigated. Local tide charts, if applicable, are sometimes available from the harbor master or port services or can be obtained from the National Ocean Service; these charts can be very helpful in planning work for the best use of daylight hours and in conjunction with the tides. Public utility companies should be contacted for updated information if the chart indicates underwater cables or other equipment. The U.S. Coast Guard also provides updated information to the chart in "Notice to Mariners" information on new hazards and changes. The location of onshore structures that could block the navigation system operation and sites which could be used for the navigation system shore stations should be noted.

10-4. Work Platforms for Underwater Sampling

Several types and sizes of work platforms, including scaffolds, barges, and ships, are available to support underwater sampling work. When a platform is selected for a site survey, a number of factors should be considered. These factors include the effects of tides, currents, and depth of water; the positioning of the platform and the capabilities for deploying and retrieving the sampler; the type of sampling equipment as well as the number, size, quality, and depth of samples; safety; and the availability of the equipment. Figure 10-1 shows a small drill rig on a scaffold. Figure 10-2 shows a barge set up for nearshore work. Figure 10-3 shows a jack-up barge that can be used to support an onshore drilling rig. Workboats and drillships are used for sampling in deeper water. A discussion of each of these factors is presented in the following paragraphs.

When a sampling operation is being planned, site data are needed on maximum and minimum water depths, tides, currents, and typical wave heights for the expected weather conditions. The minimum water depths will determine the draft of the vessel that can be used. The height of the vessel, including antennae, navigation equipment, and crane boom, will be important if bridges or other obstacles have to be negotiated.

If samples are required from specified points or locations, then navigation, positioning, and station-keeping systems will affect the type of work platform which is selected. Frequent moves to different locations will require a platform that is easily maneuvered and quickly anchored. The positioning system will depend on the physical characteristics of the site to be surveyed. Vessels typically have from one to four anchors, whereas it may be necessary to install temporary anchors and winches on a barge. Some vessels have bow thrusters which allow them to hold a position without anchoring or with only a minimal number of anchors. If the navigation system on the vessel cannot provide the accuracy required, a supplemental system will have to be employed. With a preplanned investigation, a priority for obtaining samples and their relative locations will allow a more efficient site survey.

The height, reach, and load capacity of the lifting equipment should be specified. Typical types of lifting equipment include cranes, winches, A-frames, and davits. Figure 10-2 shows a barge with a crane, an A-frame, and a winch. The vertical and horizontal clearances for an A-frame should be known because the horizontal clearance varies from the top to the bottom of the A-frame. Figure 10-4 shows a sampling device hung from a pair of davits along the side of a vessel; it can be deployed with winches. Figure 10-5 shows a sampler deployed with a mobile crane mounted on a barge. Because of insufficient deck space, the head of the corer was supported overwater by the crane while its base was placed on the deck as the core was removed.

The support requirements for the sampling device such as power, compressed air, water flow and pressure, deck space and lifting capacity to deploy and retrieve the sampler, and core handling and storage space, need to be considered when the work platform is selected. For example, the type of sampling device should be selected based upon the quality, diameter, and depth of samples needed. However, if the work platform does not have the required support equipment, such as an internal power source or sufficient lifting capacity, then space must be available on the vessel for a generator or positioning an auxiliary A-frame hoist and other support equipment. As an option, alternative types of sampling devices should be considered.

Safety is a very important consideration when a work platform is selected. The vessel should meet U.S. Coast Guard requirements. Life vests and standard personal safety equipment must be provided.

During the coring operation, appropriate shapes (flags) should be displayed indicating the vessel is restricted in its ability to maneuver.

Locating a vessel for an offshore survey can sometimes be difficult. Local harbor masters, port services, or port operations offices can be used as a starting point. Commercial companies have equipment varying from drill ships to workboats to barges for rent; sport fishing boats are also suitable for site work. Many Army installations and Navy bases or shipyards have vessels that can be used. Military reserve units often have vessels that can be used with enough advanced notice. The Military Sealift Command (MSC) and NOAA have many vessels available for offshore work; however, MSC and NOAA require long lead times for scheduling the use of these vessels.

As can be seen by the data in the previous paragraphs, the selection of the work platform is a combination of science and art. No single work platform will satisfy all needs for all nearshore and offshore drilling and sampling operations. The work platform must be selected which will allow the highest quality samples to be obtained at the least cost by using available equipment and techniques applied with experience and sound judgment as dictated by the specific site conditions.

10-5. Underwater Samplers

The choice of an underwater sampler for a particular site investigation depends on the sediment type(s); the type of data needed from the samples; the quality, depth, and diameter of the samples; the depth of water at the site; available work platforms; environmental conditions; and, of course, funding constraints. The most common types of underwater samplers can be divided into three categories based upon the method of deployment, i.e., free samplers, tethered samplers, and drill string samplers. These types of samplers are generally available through commercial enterprises and government agencies. A discussion of each sampler, including its operation, deployment and retrieval requirements, size and quality of sample, the types of sediments in which it can be used, and vessel and support requirements, follows.

a. Free samplers. Untethered samplers, including boomerang samplers, hand-held diver-operated samplers, and remotely operated vehicle (ROV) samplers, can be deployed with minimal attachments to the work platform. Boomerang corers are truly free from any attachment; hand-held diver-operated samplers are dependent upon whether or not the diver is tethered to the work platform; whereas the particular design of ROV samplers determines whether or not they must be tethered.

(1) *Boomerang corer.* The Boomerang corer, as its name implies, returns to the surface after it has been deployed and a sample has been obtained. The corer consists of an expendable ballast portion which contains a plastic core tube connected to two glass floats. To deploy, the sampler is dropped off the work platform and is permitted to free-fall through the water and embed in the seafloor. The sediment-filled core tube is returned to the surface by the glass floats, leaving the expendable ballast portion embedded in the seafloor. The Boomerang corer needs a minimum depth of water of about 10 m (33 ft) to stabilize and obtain its maximum velocity for embedment and maximum sample length. Theoretically, there is no maximum water depth for this device; cores have been obtained from depths exceeding 8,800 m (29,000 ft).

Since the manufacturer provides a detailed manual with the Boomerang corer that is shown in Figure 10-6, only a brief description of the device is presented herein. The corer is 203 cm (80 in.) long overall and weighs 85.7 kg (189 lb) in air and 59.0 kg (130 lb) in water. The expendable ballast portion is a steel shell which serves as the core barrel (lower end) and the float housing (upper end). On the outside of the core barrel is a sliding lead pilot weight attached by a wire to a release lever located in the float housing.

The retrievable and reusable float portion consists of two glass floats and a core tube. The plastic core tube, which is 6.7-cm (2-5/8-in.) ID by 7.3-cm (2-7/8-in.) OD by 122 cm (48 in.) long, is fitted with a stainless steel core catcher in the bottom end and a butterfly valve assembly in the top. The glass floats are attached to the valve assembly; one of the floats usually contains a battery-operated flashing light or pinger to aid in locating the float portion after it has returned to the surface.

The operating sequence of the Boomerang corer is outlined in Figure 10-7:

Step 1: The corer is dropped over the side of the vessel in a vertical orientation. During this operation, care is needed to ensure that sudden swings of the corer are avoided which could cause the pilot weight to slide up the barrel and release the floats.

Step 2: As the corer descends, the hollow rubber ball is compressed by water pressure until it is released, usually at a depth of 10 to 15 m (33 to 49 ft).

Step 3: When the corer embeds in the seafloor sediment, the pilot weight is pushed up with respect to the core barrel, the float release lever is tripped, and the floats are released.

Step 4: As the floats begin to rise, a pin which holds the butterfly valve open is pulled out; this action allows the butterfly valve, which helps to retain the core in the sampling tube, to close. The floats rise and pull the core tube to the surface.

Step 5: When the floats reach the surface, they can be retrieved by hand or by whatever lifting equipment is available. Once the core has been retrieved, the sample should be identified, field logs should be completed, and the sample should be sealed in the plastic tube or placed in a sample jar for storage and shipment to the laboratory.

Although a full length sample is not always obtained in dense sand, a high-quality representative sample of cohesive or cohesionless soils can usually be obtained with the Boomerang corer because of its high-impact velocity. The advantages of this device include the ease in which it may be deployed and retrieved, its relatively accurate positioning on the seafloor as compared to its drop location, and the speed at which a series of cores can be taken. Because of its simplicity, the Boomerang corer can be deployed from almost any vessel or work platform. Depending upon how many corers are being used and how much associated equipment is needed, only a small amount of deck space is usually needed. Tight station-keeping capabilities are not required, although it is a good idea to record the locations where the corers are deployed. Boomerang corers can be deployed in fairly rough seas; the limiting factor is that the vessel must be capable of maneuvering to recover the core. Its disadvantages include the large wall thickness of the core barrel plus liner relative to the core diameter and the short sample length typically obtained for sands.

(2) *Diver-operated hand-held corers.* There are many different versions of diver-operated hand-held corers. Although the operating depths of hand-held corers are controlled by the depth limits imposed on divers (generally less than 30 m or 100 ft), these corers provide a method of sampling areas that are difficult to reach by other coring methods. In general, hand-held corers use a clear plastic core tube that can be pushed or driven into the sediment by a scuba diver. Typically, the core tubes are 3.8 cm (1-1/2 in.) in diameter by 0.6 to 0.9 m (2 to 3 ft) in length, although some larger diameter core tubes are available. Fairly high-quality samples can be obtained in cohesive and cohesionless sediments, although the sample quality and retrieval are dependent upon the diver's skill with the tool. Consequently, training and practice can make a significant difference. The main advantage of this type of corer is that samples

can be obtained from otherwise inaccessible areas. The vessel requirements for supporting the hand-held corer are minimal and are determined mostly by diver needs. The disadvantages include the small diameter of the core and its short length.

One type of hand-held diver-operated corer that is available to government agencies through Naval Facilities (NAVFAC) Ocean Construction Equipment Inventory (OCEI) is described herein. The OCEI corer (Figure 10-8) consists of an aluminum guide frame, a stainless steel hammer, and a core head; it is 119 cm (47 in.) long, weighs 10.4 kg (23 lb) in air and 7.3 kg (16 lb) in water, and can be used to obtain a 3.8-cm- (1-1/2-in.-) diam by 76-cm- (30-in.-) long sample. To obtain a sample, the corer should be placed upright with the base positioning tabs resting on the diver's fins; this placement positions the piston at the seafloor surface. To sample, the clamp on the piston rod is released and the core tube can be pushed into the sediment using the handles on the head. When the core tube can no longer be pushed by the diver (the diver is neutrally buoyant), the hammer can be used to further embed the tube, provided that the free-fall hammer blows are counted. When the core tube is fully embedded, the diver should lock the piston rod clamp before the corer is pulled out of the sediment. Before the diver returns to the support vessel with the core, a cap should be placed on the bottom of the core tube to retain the sample. After the core tube has been removed from the frame, the plastic tube can be cut off at the top of the sample and capped, or the piston can be positioned on top of the sample, the tube filled with seawater, and then capped. The caps on the top and the bottom of the tube should then be taped, the core should be labeled, and the field logs, including the number of free-fall hammer blows, should be updated.

(3) *ROV-operated samplers.* There are some sampling devices that can be operated by the manipulator arms on remotely operated vehicles (ROV). Typically, these samplers are research tools which are designed for use with a specific ROV. Generally, ROV-operated samplers can be used to obtain fairly short, small-diameter cores, are relatively expensive to operate, and are intended for use in deep water. However, there are situations where the ROV device is the best solution to the sampling problem, such as where accessibility is a problem and the depth of water is too great for divers.

b. Tethered samplers. Tethered samplers are attached to the work platform by some type of umbilical support cable or lowering wire, such as a wireline. Tethered samplers can be subdivided into dredges and grab samplers, box corers, gravity corers, and bottom-resting samplers.

(1) *Dredges and grab samplers.* Dredges and grab samplers can be used to obtain disturbed and perhaps nonrepresentative, surficial sediment samples of the seafloor from almost any depth of water. Although there is some overlap between what is called a dredge and a grab, dredges generally are dragged across the seafloor to obtain a sample, whereas grabs have jaws that close after penetrating the seafloor. Examples of each are given in Figure 10-9. Vessel positioning is not critical for the use of these samplers, although some navigational data are needed. Because some components of the seafloor may not be easily sampled, whereas other components may be washed out during sample retrieval, dredge and grab samples are suitable only for identifying the sediment type and should not be used for determining engineering properties. Because of the wide variety of dredge and grab samplers available and the relative simplicity of operation of each, the details for operation and deployment of various samplers are not explored herein.

(2) *Box corers.* A box corer is a device that contains a box which takes a large, relatively undisturbed sample when lowered to the seafloor by a wireline from the work platform. The box corer is pushed into the sediment by its own weight. When the deployment line is retracted, the bottom of the box is closed off by a rotating spade before the box corer is lifted. Most box corers can be operated in any water depth.

Box corers are available from several manufacturers, and therefore the design, size, and operation of each may vary slightly. The boxes are usually constructed of stainless steel or aluminum; sizes range from 10 by 30 by 30 cm (4 by 12 by 12 in.) to 30 by 30 by 90 cm (12 by 12 by 36 in.) to as large as 50 by 50 by 60 cm (20 by 20 by 24 in.). Most boxes have a bottom plate for supporting the sample in transport and a removable side for access to the sample after it has been retrieved. The parts of the box corer and its operational sequence are presented conceptually in Figure 10-10.

The box corer should be prepared for use according to the manufacturer's instructions. Care should be taken to ensure that the safety pins which prevent pretripping are set correctly. After the sampler is lifted off the deck, the pins supporting the weight column should be removed. Safe lowering rates for box corers depend on the seas and the type of device. For example, in calm seas, the box corer can be lowered fairly rapidly but should be slowed considerably as it nears the bottom to allow the corer to stabilize; in rough seas, the box corer should be lowered at a moderate rate and should not be slowed as the corer nears the bottom. When the box corer touches the bottom, deployment of the wireline should be stopped immediately to prevent excess line from getting tangled and interfering with the operation of the corer. If desired, a bottom-sensing pinger can be attached to the wireline; to prevent damage to the pinger during retrieval of the sampler, the wire should be marked to alert the winch operator of the location of the pinger.

After the box has been driven into the sediment by its weight, the corer can be retrieved. As the wireline is recoiled, the spade is rotated to close off the bottom of the box before the box is pulled out of the seafloor. The corer can be retrieved as fast as is possible but should be slowed as it nears the water surface. Once the corer is out of the water, it should not be set on the deck until the weight column support pins have been placed and a rope has been tied around the spade to prevent it from moving as the tension in the wireline is released.

To remove the sample box, a bottom plate must be inserted between the spade and the bottom of the box and clamped before the spade is released and returned to its original position. If the box corer is equipped with an integral spade, the box assembly can be removed from the frame by simply loosening two bolts. After the box sample has been removed from the sampler, the sample can be extruded and subsampled or stored in the box and sealed. Sampling logs for box cores should include information such as the type of box corer, its size, the weight column, the size and/or weight of sample, subsamples taken, and observations or remarks.

Box corers require a midsized vessel with deployment equipment that will provide the height clearance necessary to deploy and retrieve the box. If an A-frame is used, both vertical and horizontal clearances should be checked. The amount of deck space required is typically small; usually a moderate working area plus space for the footprint of the corer is sufficient. Although it is not necessary for the vessel to stay in a fixed position during the sampling operation, position data should be recorded at the instant the corer touches bottom. It should also be noted that core recovery is usually enhanced if the corer is brought to the surface of the water in a nearly vertical retrieval pattern.

The principal advantage of a box corer is that a large, relatively undisturbed sample of cohesive material can be retrieved. The disadvantages of the box corer include the short length of sample which is retrieved and the difficulty of sampling cohesionless sediments which usually wash out of the box corer during retrieval.

(3) *Gravity corers.* Although several types of gravity corers are available, all are operated similarly. In general, gravity corers consist of a large weight on top of a steel core barrel which contains a plastic

liner. The corer is lowered and raised from the seafloor by a wireline, although during the actual sampling process, the corer is allowed to free-fall and penetrate the sediment. Gravity corers can be used in almost any water depth; however, in shallow water, adequate free-fall distance must be available for the sampler to deploy.

Gravity corers have been classified by size or by operational method. Historically, gravity corers were divided into three groups based upon size: Phleger corers, Ewing corers, and deep-ocean corers. Today, several sizes of gravity corers are available; consequently, the operational method, which is based upon the requirement that a valve or internal piston is used to enhance sample recovery, provides a better classification system. Typically, the smaller, shorter corers use a valve and are commonly referred to as “gravity” corers, whereas the larger, longer corers use a piston and are referred to as “piston” corers. A discussion of the gravity and piston corer is presented herein.

(a) *Valve-type gravity corers.* Gravity corers are manufactured by several companies and can be designed to meet almost any coring requirements. The two most common devices are the Phleger and Ewing corers. The Phleger corer, which is shown in Figure 10-11, is typically 0.9 to 1.2 m (3 to 4 ft) long, weighs about 18 kg (40 lb), and can be used to obtain a sample 3.8 cm (1-1/2 in.) in diameter by 0.6 m (2 ft) in length. The Ewing corer, which is illustrated in Figure 10-12, will vary in weight and length depending upon the sample size; the weight of the sampler ranges from 90 to 450 kg (200 to 1,000 lb) and can be used to obtain a sample that is 6 cm (2-1/2 in.) in diameter by 1.8 to 3.0 m (6 to 10 ft) in length. These devices are strikingly similar. The wireline is attached to the bail, which is located at the top of each corer. Below the bail is the weight stand; depending upon the type of sampler, the weights are either permanent or removable. The core barrel, which is lined with a plastic liner and core catcher, is located below the weight stand. A core cutter is attached to the bottom of the core barrel. A check valve, which is used to retain the sample, is located at the top of the weight stand.

Before the gravity corer is deployed, the device should be assembled and inspected according to the manufacturer's instructions. The check valve should be inspected to ensure that it is working properly. If a trip arm release as shown in Figure 10-13 is used, it should be inspected for proper operation and the presence of the safety pin. When the gravity corer is deployed, it can be lowered in the water very rapidly but should be stopped as soon as the trip arm is released or the corer hits bottom. As soon as the core has been obtained, the corer should be slowly pulled free of the bottom and then returned to the surface as rapidly as possible. If the corer is relatively short with sufficient deck space and lifting clearance available, the corer should be retained in a vertical orientation until the core has been removed. As soon as the core cutter has been disconnected from the core barrel, the core liner can be removed. However, if the check valve creates a tight seal at the top of the sample, it may be necessary to break the suction before removing the core to prevent core disturbance. After the core liner has been removed from the corer, it should be capped, labeled, and stored as suggested in the section on core handling. The field logs should be updated in a timely manner.

Vessel requirements for deploying gravity corers will vary slightly, depending upon the specifics of the corer. Generally, the lifting equipment should be capable of handling the weight and the height of the full corer and the tripped cable, if a trip arm is used. The requirement for keeping the vessel at a fixed location is not critical unless it is necessary to sample a specified point; however, the vessel should not be permitted to move so far away from the embedded corer that it is pulled up at an angle.

The advantages of gravity corers include the ease of handling and the simplicity of operation. The principal disadvantage is the short sample length. The difficulty of obtaining a longer core is caused by selective sampling; as the gravity corer penetrates the formation, the sidewall friction between the

sediment and the liner builds up and eventually causes a plug to form at the core cutter. In an attempt to sample deeper sediments with a gravity-type corer, a piston was added; the piston-type gravity corer is discussed in the following paragraph. It is appropriate to note herein that Hvorslev (1949) recommended the maximum length-to-diameter ratio for an undisturbed sample of cohesive soil should be of the order of 10 to 20; for offshore investigations, the length-to-diameter ratios are frequently much larger. Perhaps, the excessive length-to-diameter ratios may cause increased sample disturbance.

(b) *Piston-type gravity corers.* A diagram of a typical piston corer is shown in Figure 10-14. The purpose of the piston is to remain at the top of the sediment and create a suction as the core barrel is pushed into the sediment; the effect of the suction is to enhance the recovery of the core and perhaps increase the length of the sample drive. As with the gravity corer, the piston corer has either a permanent weight or an adjustable set of weights at the top. Most piston corers can be used to obtain a 6.3- to 6.7-cm- (2-1/2- to 2-5/8-in.-) diam core; the length of the core is usually 3 to 15 m (10 to 50 ft), depending upon the type of sediment, although cores up to 40 m (130 ft) in length have been obtained. The length of the piston corer can be adjusted by adding 3-m (10-ft) lengths of core barrel and using longer plastic liners.

With the exception of a few steps for the operation of the piston, the operation of the piston-type gravity corer is similar to the operation of valve-type gravity corer, as noted in Figure 10-13. After the piston corer has been assembled according to the manufacturer's instructions, three additional steps are required before the sampler is deployed: the trip wire length should be adjusted, the clearance of the lifting equipment should be checked, and the core barrel should be filled with water. The length of the trip wire should be preset before the sampler is deployed to ensure that the piston is stopped and held at or slightly above the sediment surface as the core barrel penetrates the formation. The length of the trip wire can be calculated by Equation 10-1:

$$L_t = V_t + L_c + F_c - (l_t - d_t) \quad (10-1)$$

where

L_t = length of the trip wire

V_t = vertical distance the trip or trigger arm must move to release the corer

L_c = overall length of the corer

F_c = free-fall distance the corer travels before it impacts the seafloor sediment

l_t = overall length of the trip or trigger weight

d_t = depth of penetration of the trigger weight into the seafloor sediment

After the sediment has been sampled, about 0.3 to 0.6 m (1 to 2 ft) of water should be separating the top of the sediment and the bottom of the piston. This separation assures that the top sediments have been sampled. If the distance between the sediment and the piston is too large, the free-fall loop is too short or the length of the trip wire is too long; then the length of the wire(s) should be adjusted by an amount equal to the length of the excess distance between the piston and the core. If the mud marks on the outside of the corer indicate a significantly greater penetration depth than the length of the core retrieved,

the free-fall loop should be shortened an amount equal to the difference between the core length and the penetration depth.

Typically, the length of the trip wire is 3 to 6 m (10 to 20 ft), depending upon the overall length of the corer and the depth of penetration of the trigger weight into the seafloor sediment; the latter value is usually 0.6 to 1.2 m (2 to 4 ft). The required clearance of the lifting equipment on the work platform can be estimated as the sum of the length of the trip wire plus the length of the core tube. Short-piston corers, e.g., 3-to 6-m (10- to 20-ft) core length, can be deployed from a small crane or an A-frame, although it may be necessary to drag the sampler across the deck. For longer piston corers, it will be necessary to drag the device across the deck and upright in the water. After the sampler is suspended in the water and the trip weight has been deployed, the core barrel should be filled with water to prevent hydrostatic pressure from pushing the piston up as the device is lowered in the water.

After the sampler has been retrieved, the core cutter must be removed, the cable attached to the piston should be disconnected, and the bottom end of the liner containing the core catcher should be cut off. After the bottom of the core has been sealed, the plastic core tube should be removed from the sampling device. When the liner is removed from the barrel, the piston stop should be detached from the liner and the top of the sample tube should be sealed. The length of the core should be measured, the length of tube containing the core catcher should be noted, and the field logs should be updated. When cores longer than 3 m (10 ft) are obtained, the core liner should be pulled out a short distance, cut off, and sealed and labeled as each segment is removed. Core barrel sections can also be removed as needed as the liner is removed from the sampler. Although the sampler must be placed horizontally to remove the core liner, the sections of core should be turned upright as soon as possible and the top of each segment should be marked.

Although high-quality samples of cohesive sediments can be obtained with the piston corer, two sampling problems may occur: flow-in and piston surge. Flow-in occurs when the corer has not fully penetrated the sediment, usually when the piston is located somewhere in the middle of the core barrel. As the wireline is pulled upward to retrieve the corer, the piston is pulled to the piston stop before the sample tube is moved; this movement creates a suction in the core liner which tends to draw sediment into the core barrel. The flow-in sediment, which is very difficult to distinguish from the actual core, is disturbed. Fortunately, this problem can be minimized by the use of a split piston. When the split piston is utilized, an upward pull on the line causes the piston to separate; the main piston locks at the top of the sediment, and the secondary piston slides upward until it rests against the piston stop. Piston surge occurs when the piston is moved as the core barrel is penetrating the sediment. Ideally, the piston remains motionless during the sampling operation. However, the wireline is stretched by the weight of the sampler as the device is deployed. When the corer is tripped, an elastic wave travels up and down the wire and causes movement of the piston. Movement of the piston is also caused by the motion of the vessel. Presently, there is no universally accepted method for solving the piston motion problem.

(4) *Vibratory corers.* Over the years, many bottom-resting samplers have been built and used to obtain seafloor samples. Most of these devices were one-of-a-kind tools that eventually fell into disuse and no longer exist. However, vibratory-type corers have remained popular and are used extensively. Although several vibratory corers are commercially available, only typical vibratory corers are discussed herein. See paragraphs 7-5 and 8-2 for additional information on vibratory samplers.

The vibratory corer consists of a vibratory head attached to the top of the core barrel. The corer is supported in a bottom-resting frame which helps to ensure that the core barrel enters the sediment vertically as well as doubling as a reaction for advancing the sampling tube. The combination of weight

and vibration is generally used to drive the core barrel into the sediment, although vibrations can be combined with impact driving for some types of devices to increase the penetration. The vibrator can be electric, pneumatic, or hydraulic. The sizes of cores range from 76 to 152 mm (3 to 6 in.) in diameter by 3 to 12 m (10 to 40 ft) in length.

The vibratory corer should be operated and deployed according to the manufacturer's instructions. Care is needed to ensure that the inside of the core barrel is washed thoroughly before a new core liner is inserted to prevent the liner from becoming wedged against the walls of the core barrel. After the liner has been inserted, the threads should be cleaned before the collar is attached. Before the sampler is lowered to the ocean floor, the length of wireline to deploy the sampler should be calculated. For certain devices, deployment of the wireline is double the length of the core; this design feature must be considered when the length of the line and the sample drive are calculated. Once the corer has reached full penetration or refusal, the corer should be retrieved and placed on the work platform. When the liner has been removed from the core barrel, the cores can be cut into sections and sealed or opened for a visual analysis, as required. If extremely long cores have been taken, it may be necessary to detach a section of the core barrel to facilitate the removal of the core liner. If a full core was not obtained, the water on top of the sample should be drained by cutting the liner above the top of the sample before the sample is handled or sealed.

The vibratory corer can be operated in most coastal waters, and a sample can be obtained in most types of sediment. The time required to obtain a core depends on the density of the sediment. However, the core is disturbed to some degree; the degree of disturbance depends on the corer as well as the type of sediment. An example of a disturbed vibratory core is shown in Figure 10-15; the thin horizontal layers of dark sediment are curved downward due to disturbance. When sampling is conducted in nearshore areas, foreign objects, such as timbers or concrete, are sometimes encountered. These obstacles prevent the corer from obtaining a full core and sometimes damage the core barrel.

c. Drill string samplers. Drill-string samplers, as the name implies, operate through a drill string. Because these samplers are covered in detail in Chapters 5 through 8, this section presents only the unique aspects of their use for offshore investigations. Drill-string samplers require an onshore type of drill rig which is installed on a drill ship for use in deep water or placed on a temporary work platform. The work platform for the drill rig can vary from a small float or scaffolding to a large offshore workboat; the size of the platform is dependent upon the size of the drill rig and the support equipment required. The problems of using drill strings deployed from a work platform or vessel include the movement of the drill string as the platform is tossed about by the seas and the need to maintain a constant bit pressure appropriate for the soil type. To minimize these problems, power swivels, as illustrated in Figure 10-16, have been used.

(1) *Vertical stabilization of the drill string.* Three techniques to stabilize a drill string against vertical movement are available: (a) a heave compensator can be used on the vessel; (b) the drill string can be clamped to the seafloor; or (c) the drill string can be anchored to the formation with an inflatable packer. A schematic diagram of each method is presented in Figure 10-17. Heave compensators are devices that damp out vessel motion relative to drill-string movement with an hydraulic ram; these devices can be attached to either the crown block or the traveling block. A crown-block heave compensator can control approximately 1.5 to 6.0 m (5 to 20 ft) of heave, whereas a traveling-block heave compensator can control approximately 1.8 to 3.6 m (6 to 12 ft) of heave. Very heavy, hydraulically operated clamps which rest on the seafloor add to the reaction force available to the drill string and provide a means to reenter the borehole, if necessary. However, these devices are rather difficult to deploy, and the support equipment requires extra deck space. An inflatable packer,

commonly known as a down-hole anchor, can be attached to the drill string just above the bit and inflated against the borehole walls during the sampling process. The device is activated by a “latch-in” sampling tool and pressurized by drilling mud. When sampling is complete, withdrawal of the sampling tool causes the packer to deflate.

(2) *Operating without motion compensation.* If a motion compensation system is not available, the sampling tools, which are illustrated in Figure 10-18, can be used. These tools include a wireline-percussion sampler, a latch-in push sampler, and an hydraulic-piston sampler. The wireline-percussion sampler consists of a sliding weight and a sampling head to which sample tubes can be attached. To obtain a sample, the weight is raised with the wireline and then allowed to free-fall to drive the sampler into the formation. However, the “hammering” effect causes sample disturbance; therefore, the number of hammer blows is usually limited to approximately 30. The latch-in push sampler relies on a short sampling time to obtain a good sample without motion compensation. When the sampler is lowered into the borehole, a mechanism latches onto the drill string; the weight of the drill string is then used to push the tube to the bottom of the borehole. When the sampler is lifted, the latch mechanism releases and the sampler is retrieved on a wireline. Waves of too short a period will not allow sufficient time for the sampler to be recovered before it is again pushed into the formation by the weight of the drill string. The hydraulic-piston sampler is a jacking unit to which a 0.9-m- (3-ft-) long thin-walled sample tube has been attached. To obtain a sample, the jacking unit is lowered through the drill string until it latches onto the drill bit. Hydraulic pressure of the drilling fluid is then used to push the sample tube into the formation. During the sampling process, the piston rests on the sediment surface. After the sample has been obtained, the sampler is retrieved by a wireline.

10-6. Special Considerations for Underwater Sampling

When working in the marine environment, certain conditions require special attention. Because saltwater and saltwater mists are extremely corrosive, one of the most important aspects of any offshore geotechnical investigation is the cleaning and maintenance of the equipment. Other problems include sample recovery and storage and the difficulty of referencing the depth or elevation of bottom sediments. Selected topics are discussed in the following paragraphs.

a. Equipment cleanup. During offshore investigations, the sampling equipment as well as the vessel may require frequent washing to remove sediment, which can cause equipment to malfunction, and to prevent safety hazards on the deck. Saltwater obtained from a small water pump or from the saltwater tap on the vessel can be used for this purpose. However, at the end of the workday, the sampling equipment, including the wire ropes and any hand tools that were exposed to saltwater, should be hosed off with fresh water to prevent corrosion. If equipment is left underwater, sacrificial anodes should be attached to the equipment to counteract corrosion; locator pingers should also be attached to all equipment before it is deployed.

b. Corrosion resistant materials. Although most offshore coring equipment is constructed of corrosion-resistant materials, such as 316 stainless steel, the equipment needs to be maintained to remain operational and safe. If a new system is being designed for use in the marine environment, a metallurgist should be consulted early in the planning phase to assist in the selection of materials.

c. Wire rope. One of the most critical pieces of equipment for underwater sampling is the wire rope or wireline. Unfortunately, it corrodes easily when it has been exposed to saltwater and is then considered unsafe to use. Although galvanized wire rope is somewhat more corrosion resistant, it, too, will corrode when exposed to saltwater for a period of time. Therefore, most vessel and crane operators

are unwilling to dip crane hooks and wire ropes into the saltwater. Consequently, lifting straps, deployment wires, wire ropes, and other equipment required for the job must be supplied as an added cost to the project. A wire-rope catalog will provide information on the bending radius of the rope and the static working loads. A good rigger or rigging manual should be consulted for properly tying or terminating wire ropes. A torque-balanced wire rope which resists spinning when the equipment is lowering is also available.

d. Sample liners. Another consideration in offshore sampling is the type of plastic liner used in the sampler. The most commonly used liner is a clear plastic made of cellulose acetate butyrate (CAB). However, CAB is not very strong, can be easily damaged, and allows some moisture loss. Other plastics which have been used for core liners include rigid polycarbonate (Lexan) and polyvinyl chloride (PVC). As compared to CAB, Lexan is fairly strong, allows less moisture loss, and is more expensive; PVC is also fairly strong and allows little moisture loss, although it is opaque and contains heavy metals that could adversely affect the results of a chemical analysis of the soil sample. Some plastics can be custom extruded to meet the coring applications, whereas others can be obtained only in stock sizes. For extruded materials, there may be a minimum order or a tooling charge.

e. Core catcher. The most common type of core catcher is the mechanical “finger” type. The finger-type core catcher is relatively inexpensive and can be reused extensively provided that it is cared for. Although it works well in cohesive soils, cohesionless soils sometimes wash out as the core is brought to the surface. For hard-to-retain sediments, two other types of core catchers are available. The retainer, which is shown in Figure 10-19, uses a polyethylene sleeve affixed to the outside of a finger-type catcher; after the core has been obtained, the bag collapses to retain the sample. Figure 10-20 shows another type of core catcher which has a sphincter closure to retain the core. When a trip lever on the core barrel is released, a nylon sleeve which is located inside the core barrel is twisted to close the bottom of the core barrel.

f. Location of the bottom. Because underwater sediments progress from muddy water, to a pea-soup consistency, to mud, and eventually to a sediment with significant strength, one of the most difficult problems dealing with underwater sampling is determining the location of the “bottom” or the “mudline.” When sampling is done, especially in support of dredging operations, determining where the mudline starts is of great importance. A method of defining the location of the bottom should be selected and specified very clearly. One method is to use a flat steel plate of a specific dimension and weight; the bottom is defined as the point at which the plate comes to rest and does not move after a defined period of time. The plate should be attached to a specified lowering line for which the amount of stretch has been defined. An alternative method is to define the “bottom” as determined by a certain apparatus, such as a fathometer or a nuclear density gauge. Several U.S. Army Corps of Engineers Districts and Laboratories have experience with these devices.

g. Gas-charged sediments. Occasionally, gas-charged sediments, which are extremely difficult to sample without disturbance, are encountered offshore. Recently, samples of gas-charged sediments have been obtained with a sampler that retains the sample in a pressurized chamber. A drill-string wireline system is used to deploy the sampler. However, samples obtained in pressurized chambers are of little value unless the sample containers are opened and the samples are prepared for testing at conditions comparable to the in situ pressures; to achieve these conditions, the laboratory testing program can be conducted inside an hyperbaric chamber.

h. Sampling logs. As compared to the boring logs maintained for onshore investigations (see Chapter 13), the sampling logs for offshore operations require additional data such as the type of vessel

or platform; the navigation system and site coordinates; the time, depth of water, tides, and weather conditions; and the size and type of sampler and sampling procedures, including lowering and retrieval rates and the pullout load. An example of a data sheet that can be modified to meet the specific needs of an underwater sampling investigation is shown in Figure 10-21.

10-7. Sample Handling and Storage

In general, the methods for handling and/or storage of samples obtained during offshore drilling and sampling operations should follow the procedures used for onshore samples, which are described in Chapter 13 of this manual. However, special considerations are required for certain aspects of offshore investigations, including subsampling box core samples, handling long core samples, and the transport and storage of samples.

Because the size of the box core is fairly large and cannot be handled easily, subsamples of the box core should be obtained onboard the vessel prior to shipping the soil samples to the onshore laboratory. To subsample a box core, a piston, which can be attached to a rigid frame above the core, is placed on the top of the sample and is used as a guide for the tube that is pushed into the box core. The diameter of the subsampling tubes should be selected based upon the laboratory tests to be conducted on the subsamples. After all subsample tubes have been pushed into the box sample, the sediment around the tubes should be removed and saved for tests such as grain-size analysis and Atterberg limits.

Long cores that are obtained in plastic liners should be cut into segments 0.5 to 1.5 m (2 to 5 ft) long, depending on the proposed testing program, shipboard storage, shipping containers, and the estimated time for storage of the segments. In general, the length of the core should be decreased as the time for storage is increased to reduce settlement and leakage. As the liner is removed from the coring device, a permanent felt-tip marker should be used to mark the segments of the tube with a consistent labeling scheme, such as the bottom segment being labeled "1" or "a," etc.; each segment should also be labeled with an arrow pointing towards the top of the sample. After a segment has been labeled and the plastic liner has been cut, the segment should be measured and its condition noted; it should then be capped, taped with plastic tape, sealed with wax or plastic wrap and aluminum foil, and labeled. As a minimum, the label should contain the name of the project, the site number or name, the core number and segment number, the length of the segment, the date the core was taken, the depth of water, the sampler type, and any observations or problems. This information can be written on the plastic tube with a permanent marker, engraved into the plastic, or written on a card and inserted into a self-adhesive plastic bag attached to the core tube.

Samples should be stored and transported under conditions that minimize or prevent additional disturbance. Recall that core samples have already been disturbed by the change of stress and temperature as a result of being sampled at the relatively cool sea floor and recovered on the warm, and possibly even hot, deck. Cores should be stored vertically in a framework that prevents them from being jostled, and if necessary can be wrapped in plastic bubble wrap to cushion them from shipboard vibrations. The storage room should be maintained at a temperature of 2 to 4 deg C (35 to 40 deg F) with a relative humidity of 100 percent to prevent the growth of marine organisms. The method of packing the cores for shipment to the onshore laboratory should be preplanned to ensure that the shipping crates are designed to minimize core disturbance and the cores are sectioned to a standard length. The top of the shipping crate (hence, the top of the cores) should always be labeled "THIS END UP." Because calcareous samples are difficult to transport without causing severe disturbance, onboard testing of these materials is recommended, if possible.

10-8. Summary

Although numerous types of equipment are available for sampling offshore formations, a well-planned sampling operation can reduce the degree of difficulty and the expenses involved by ensuring that the proper equipment is available to obtain the required number of samples of satisfactory quality. Nearly all of the samplers discussed in this chapter can be used to sample cohesive materials. However, bottom-resting devices may sink under their own weight and therefore cannot be used for sampling soft sediments. For cohesionless soils, vibratory corers and wireline samplers can be used, although samples obtained with the vibratory corer are disturbed, whereas samples obtained with wireline samplers are fairly expensive. Specialized core retainers will help retain cohesionless soils in the sample tube. Rock sampling will likely require a drill-string sampler, although a few bottom-resting rock corers have been built for sampling the top of rock formations. Calcareous formations can be sampled by most of the devices discussed in this chapter. However, the effect of sample disturbance is unknown because the engineering behavior of calcareous materials cannot be predicted by conventional soil mechanics theory. Additional information on offshore sampling is available in the references cited in the section entitled "Bibliography" in Appendix A.

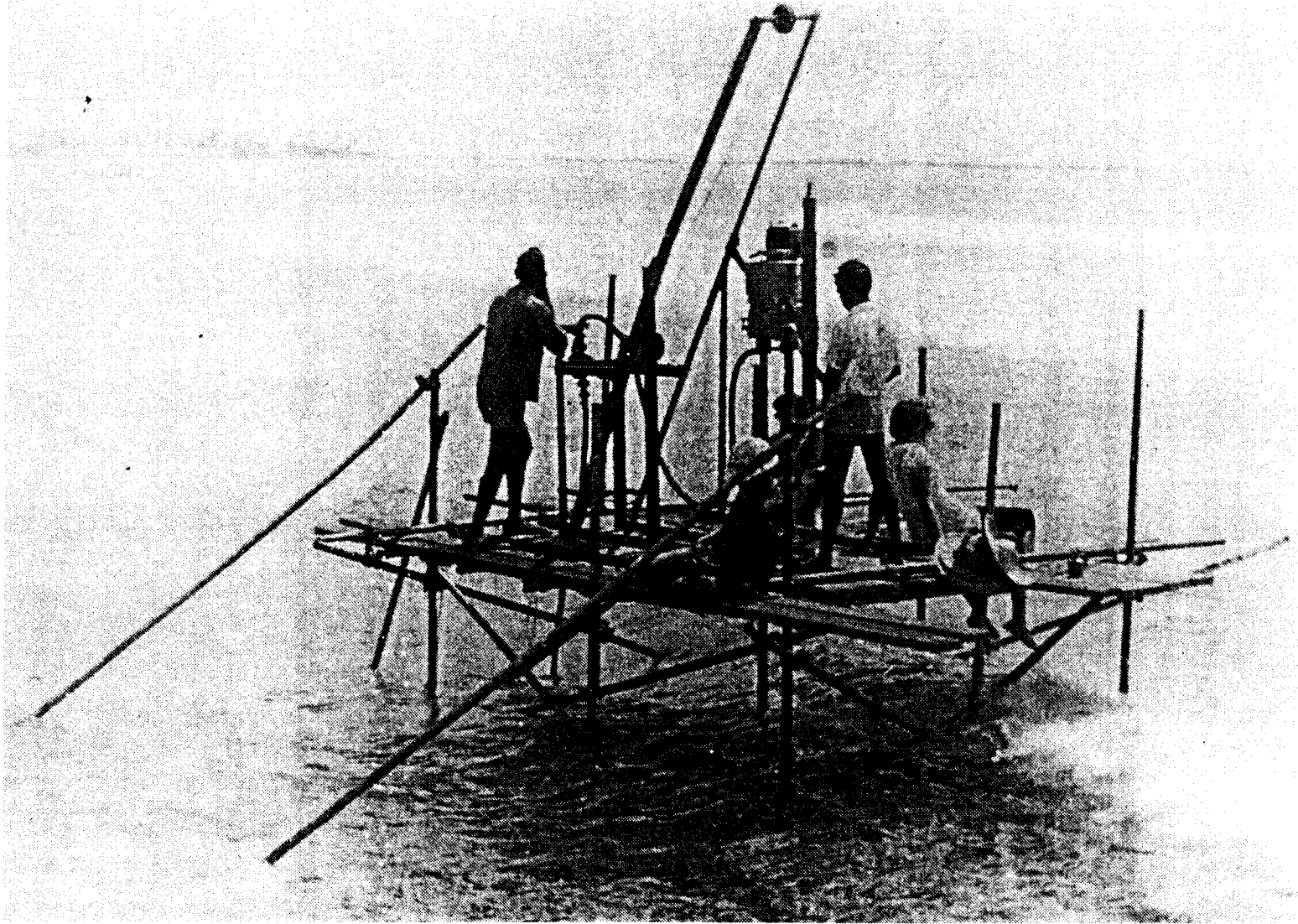

Figure 10-1. Photograph of a small drill rig on a scaffold. Note: Safety is a very important consideration for Corps of Engineer Projects. Safety items, including hardhats, gloves, safety shoes, protective clothing, life vests, and dust or vapor masks, should be worn, as appropriate, for the particular drilling and sampling operations. (Figure provided by the U.S. Naval Facilities Engineering Service Center)

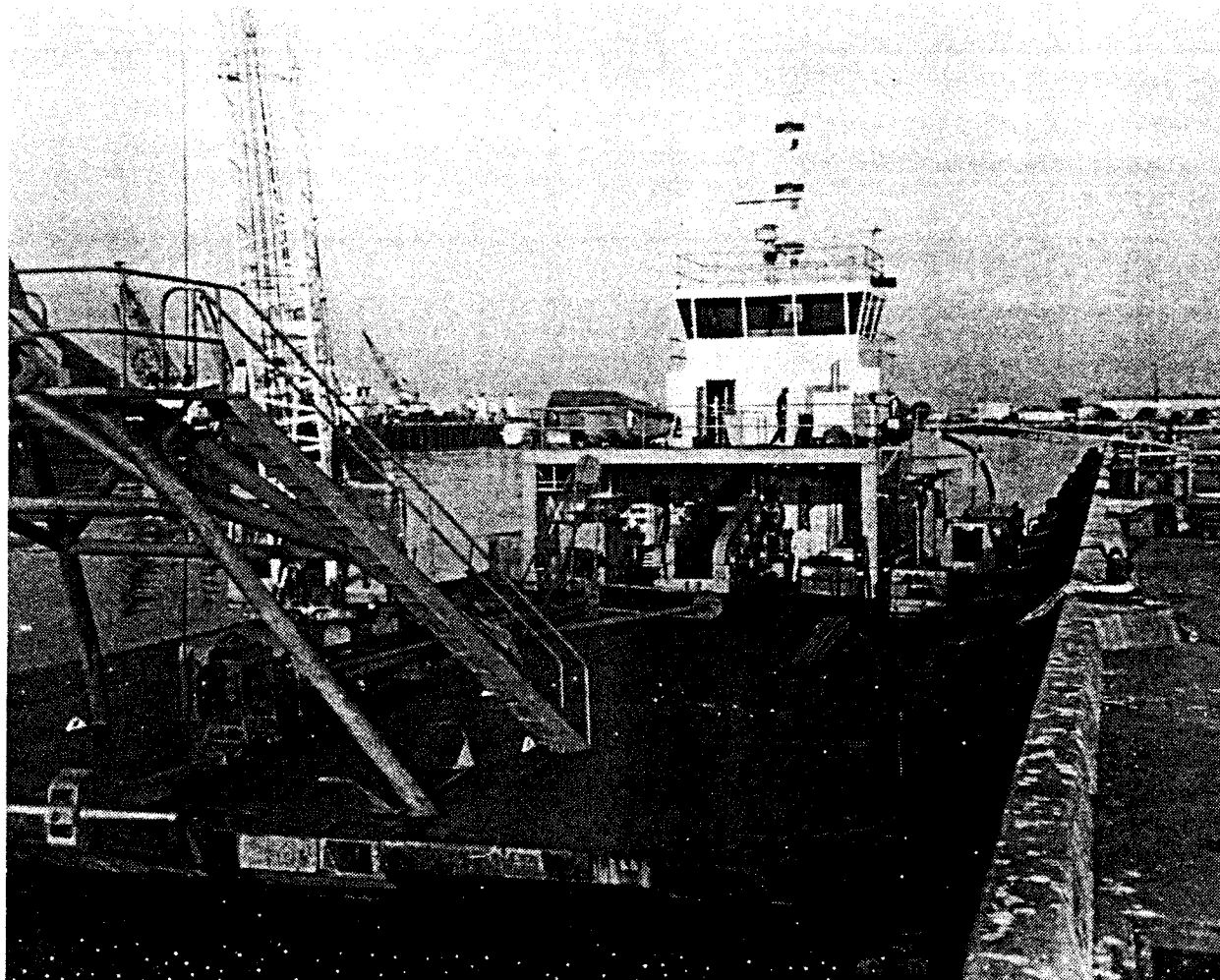

Figure 10-2. Photograph of a barge set up for nearshore work. Note the crane, A-frame, and winch for lifting and lowering drilling equipment. (Figure provided by the U.S. Naval Facilities Engineering Service Center)

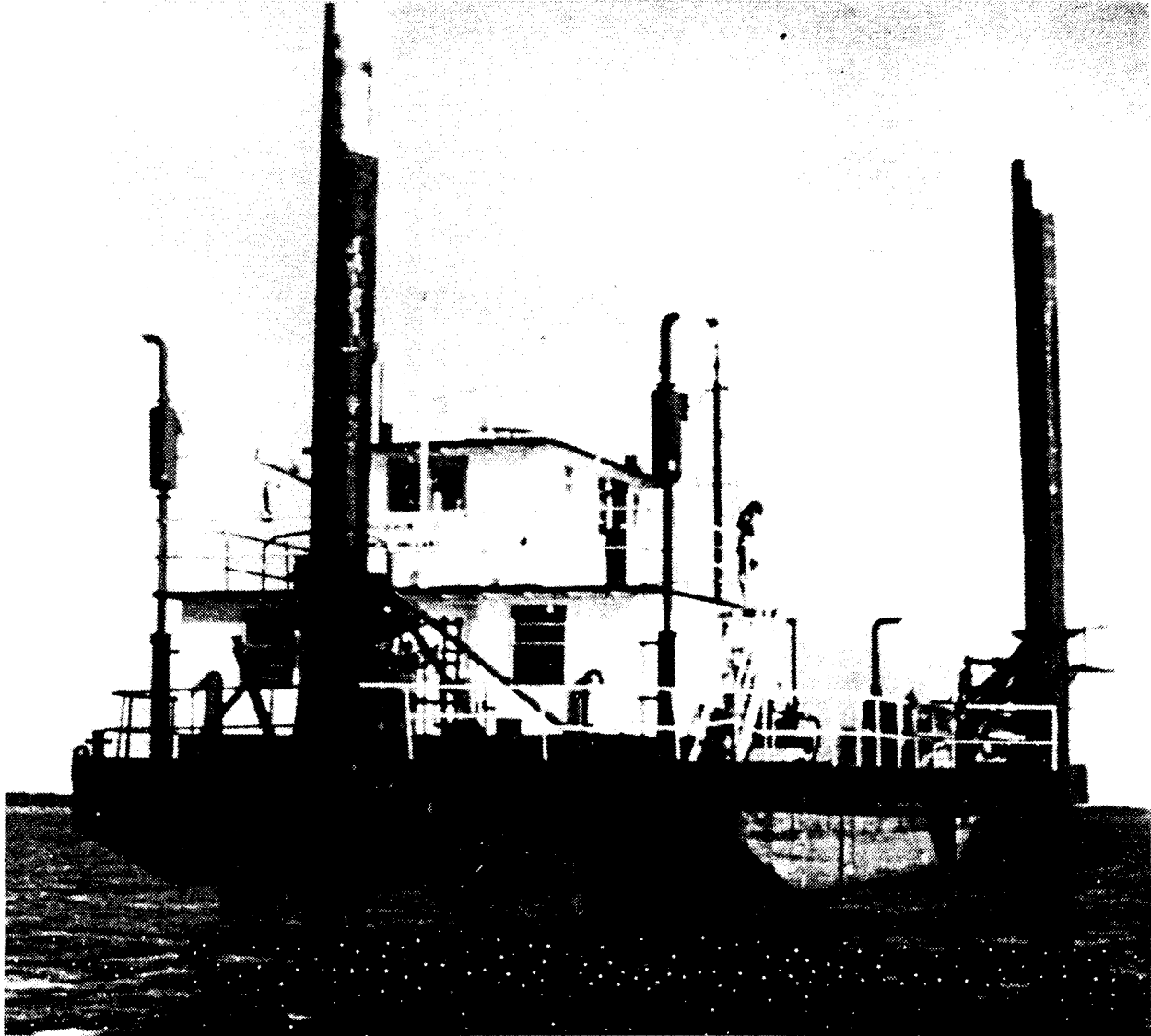

Figure 10-3. Photograph of a jack-up barge that can be used to support an onshore drilling rig. (Figure provided by the U.S. Naval Facilities Engineering Service Center)

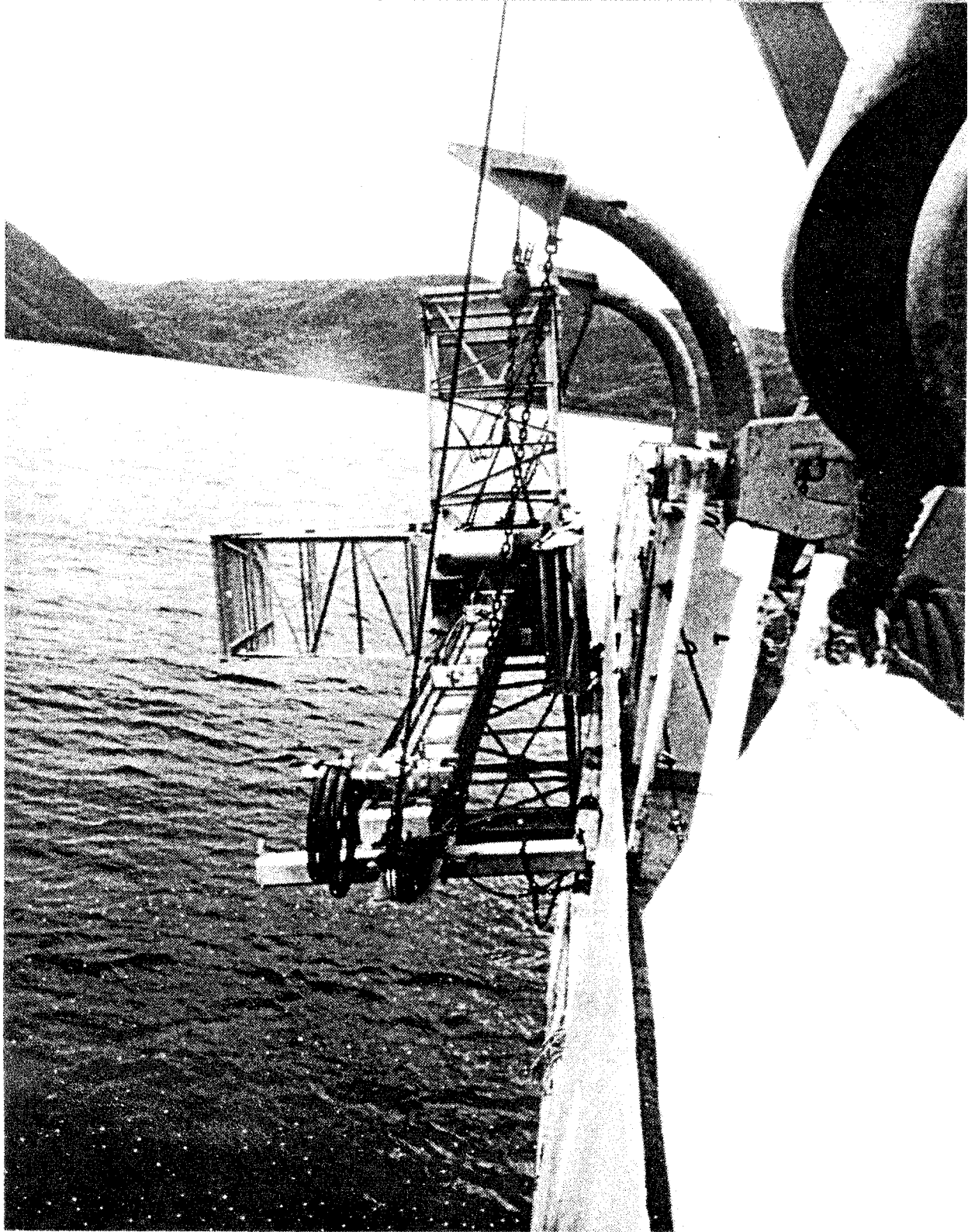

Figure 10-4. Photograph of a sampling device hung from a pair of davits along the side of a vessel. (Figure provided by the U.S. Naval Facilities Engineering Service Center)

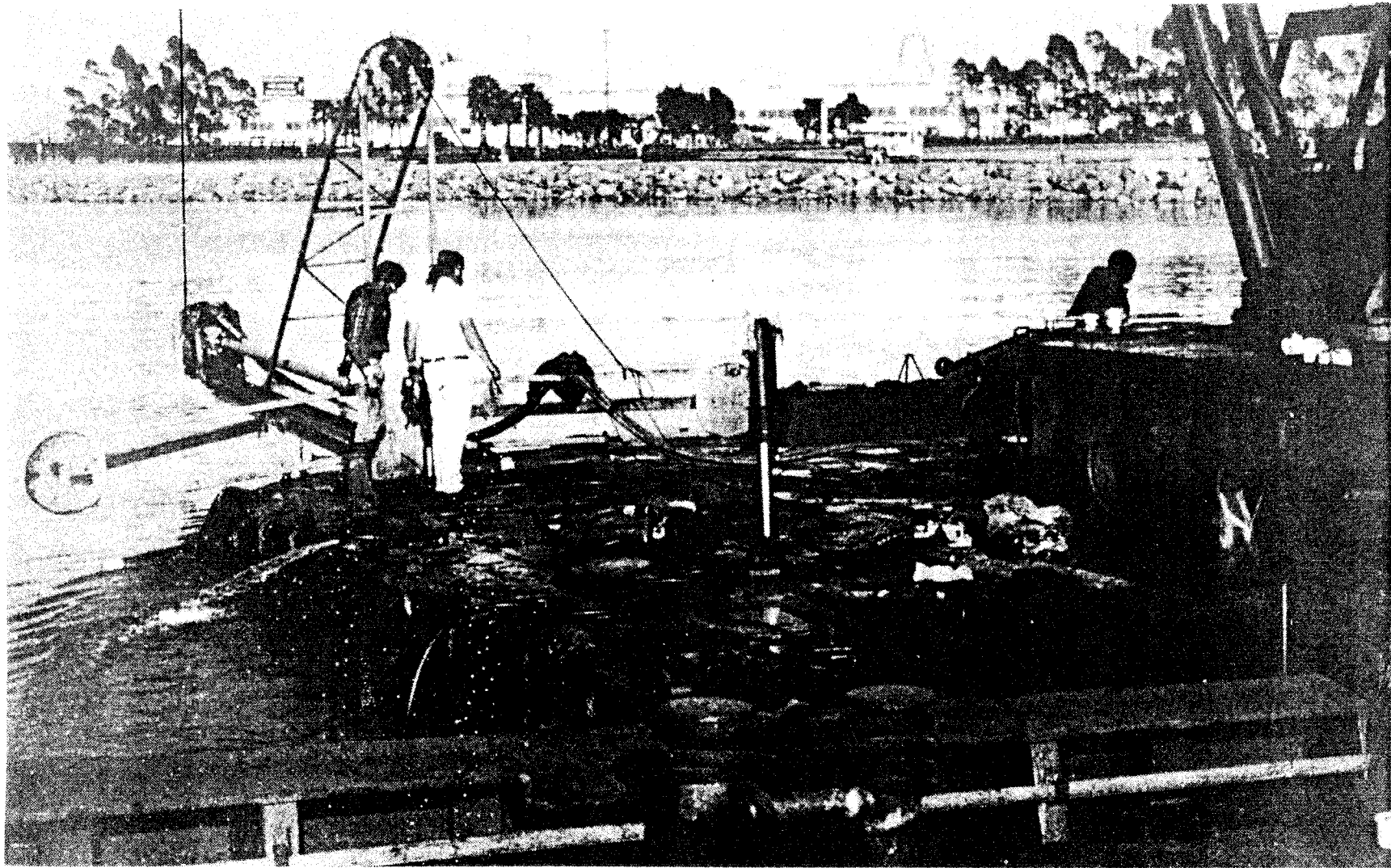

Figure 10-5. Photograph of a sampler being deployed with a mobile crane mounted on a barge. Because of insufficient deck space, the head of the sampler was supported over water by the crane while the base of the sampler was placed on the deck as the core was removed. Note: Safety is a very important consideration for Corps of Engineers projects. Safety items, including hardhats, gloves, safety shoes, protective clothing, life vests, and dust or vapor masks, should be worn, as appropriate, for the particular drilling and sampling operations. (Figure provided by the U.S. Naval Facilities Engineering Service Center)

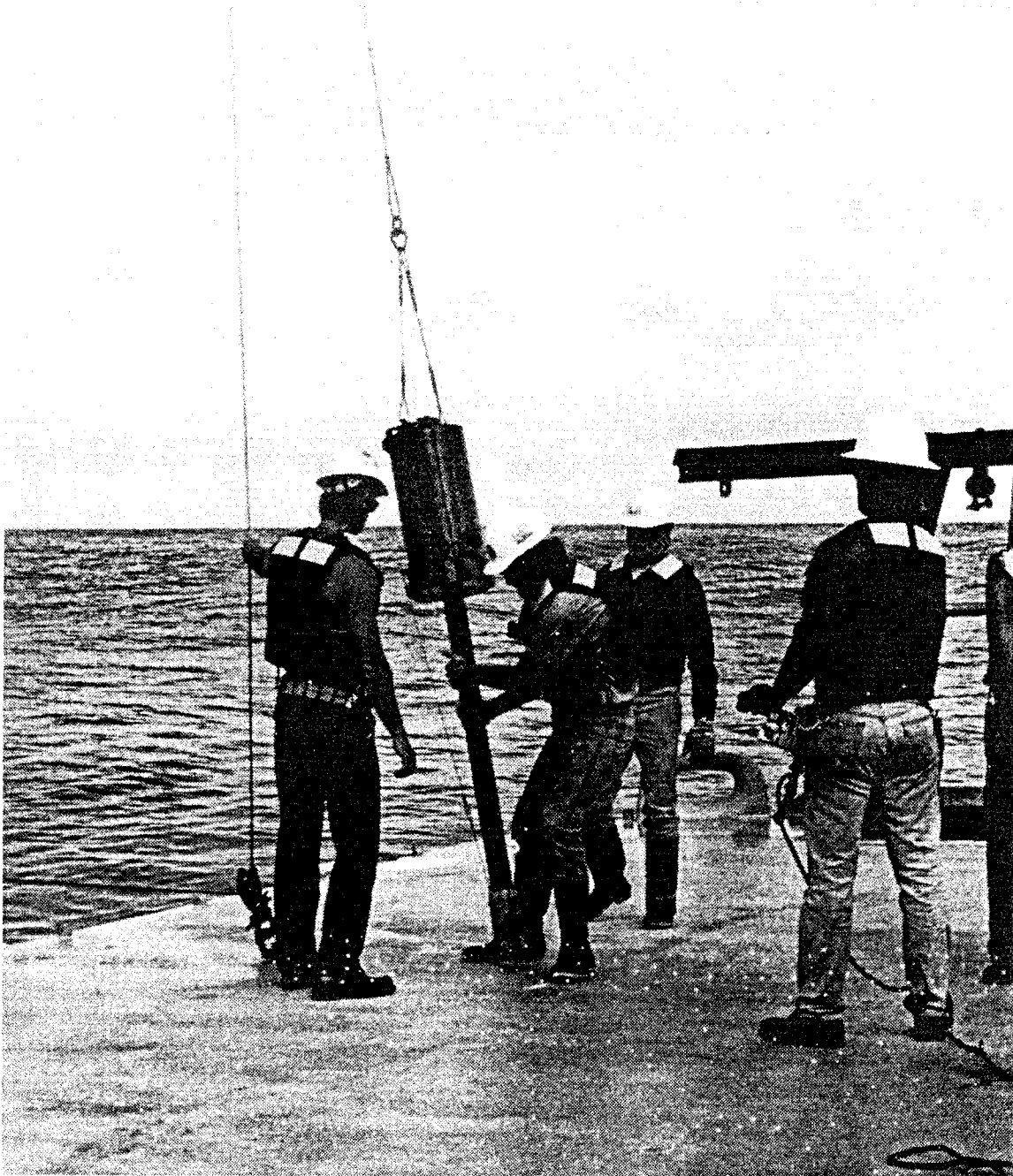

Figure 10-6. Photograph of a Boomerang corer. (Figure provided by the U.S. Naval Facilities Engineering Service Center)

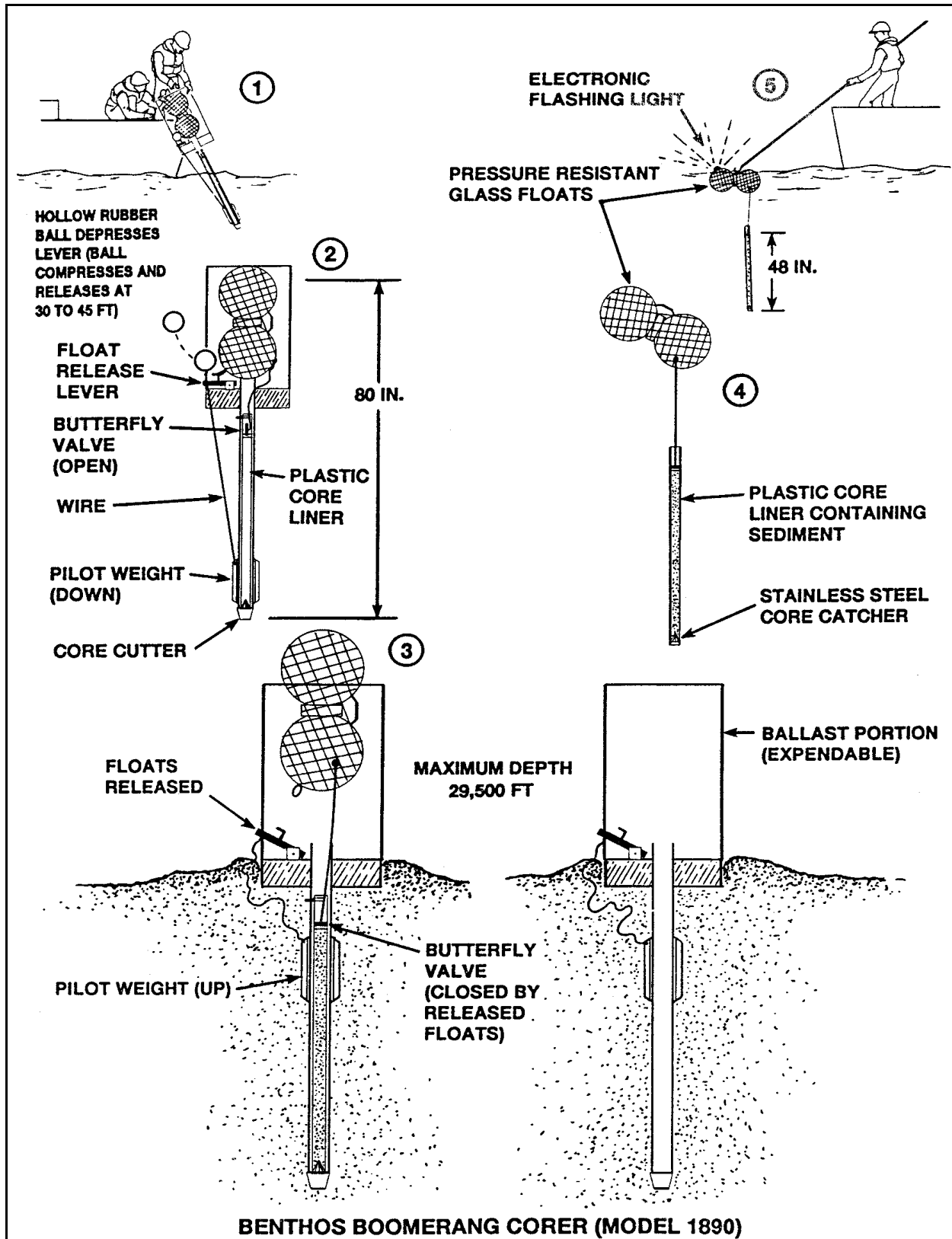
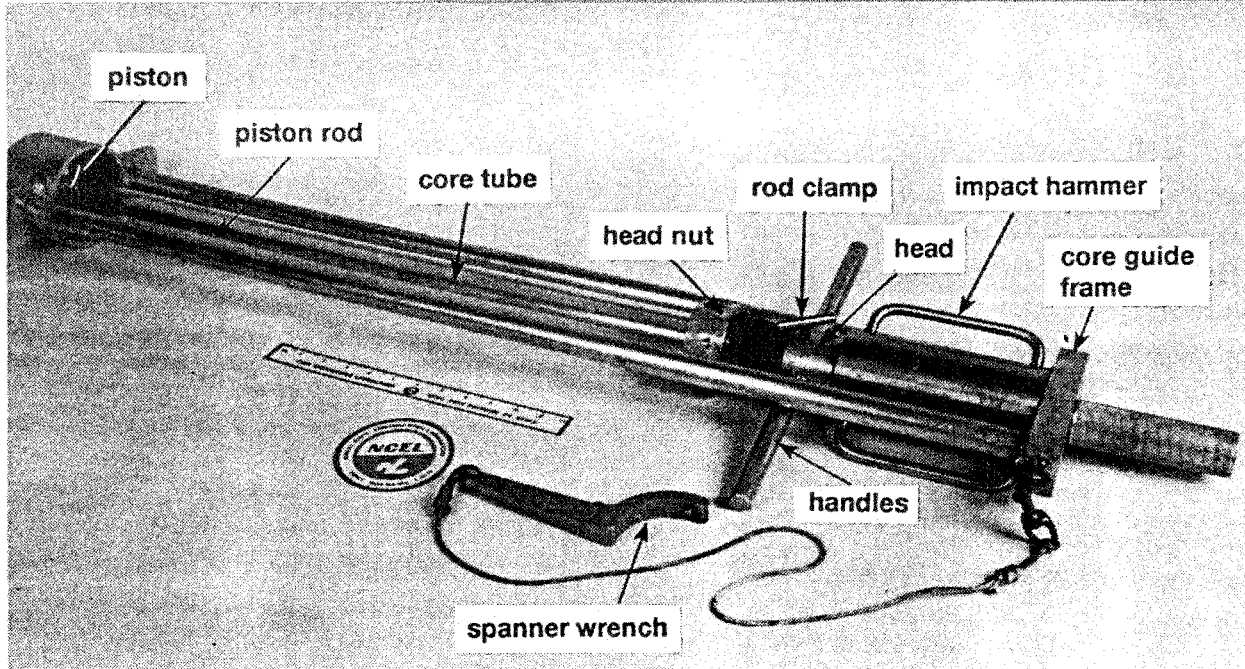
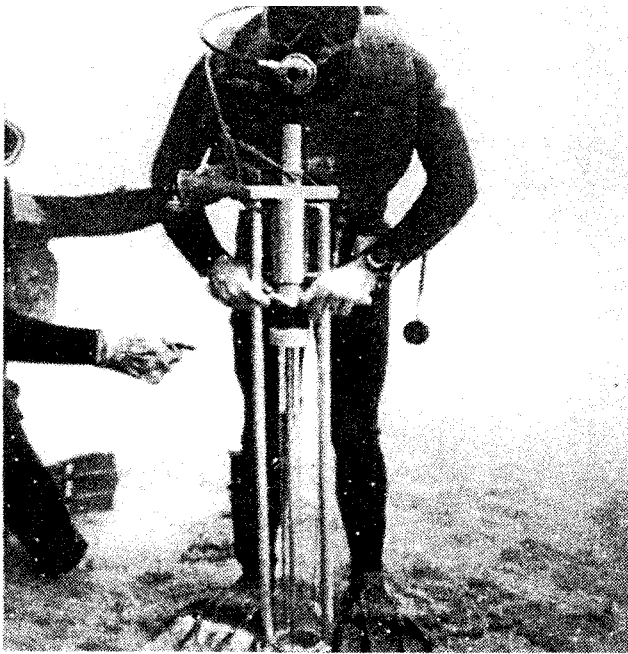

Figure 10-7. The operating sequence of the Boomerang corer. (Figure provided by the U.S. Naval Facilities Engineering Service Center)



a. Diver-operated corer with parts identified



b. Diver and partner operating corer underwater

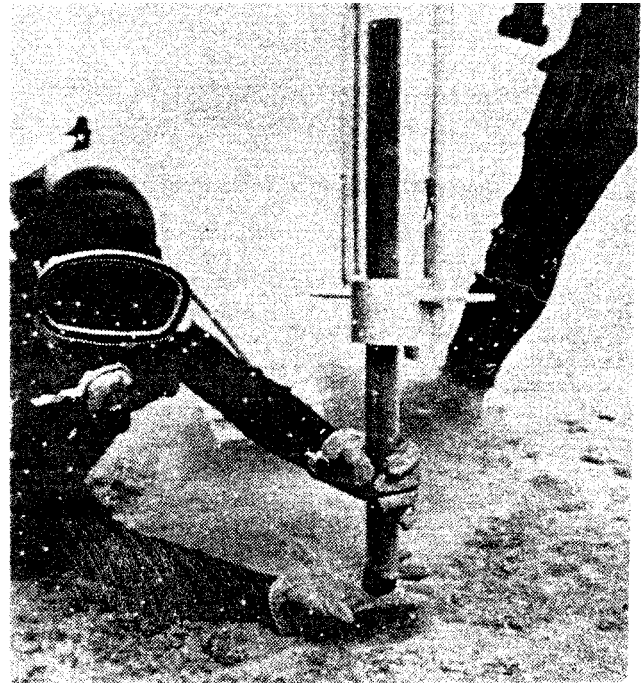

c. Divers capping bottom of core after pulling it out of the seafloor

Figure 10-8. Photograph of a hand-held diver-operated sampler available to government agencies through NAVFAC's Ocean Construction Equipment inventory. Note: Safety is a very important consideration for Corps of

EM 1110-1-1804

1 Jan 01

Engineers projects. Safety items should be worn, as appropriate, for the particular drilling and sampling operations (Figure provided by the U.S. Naval Facilities Engineer Service Center)

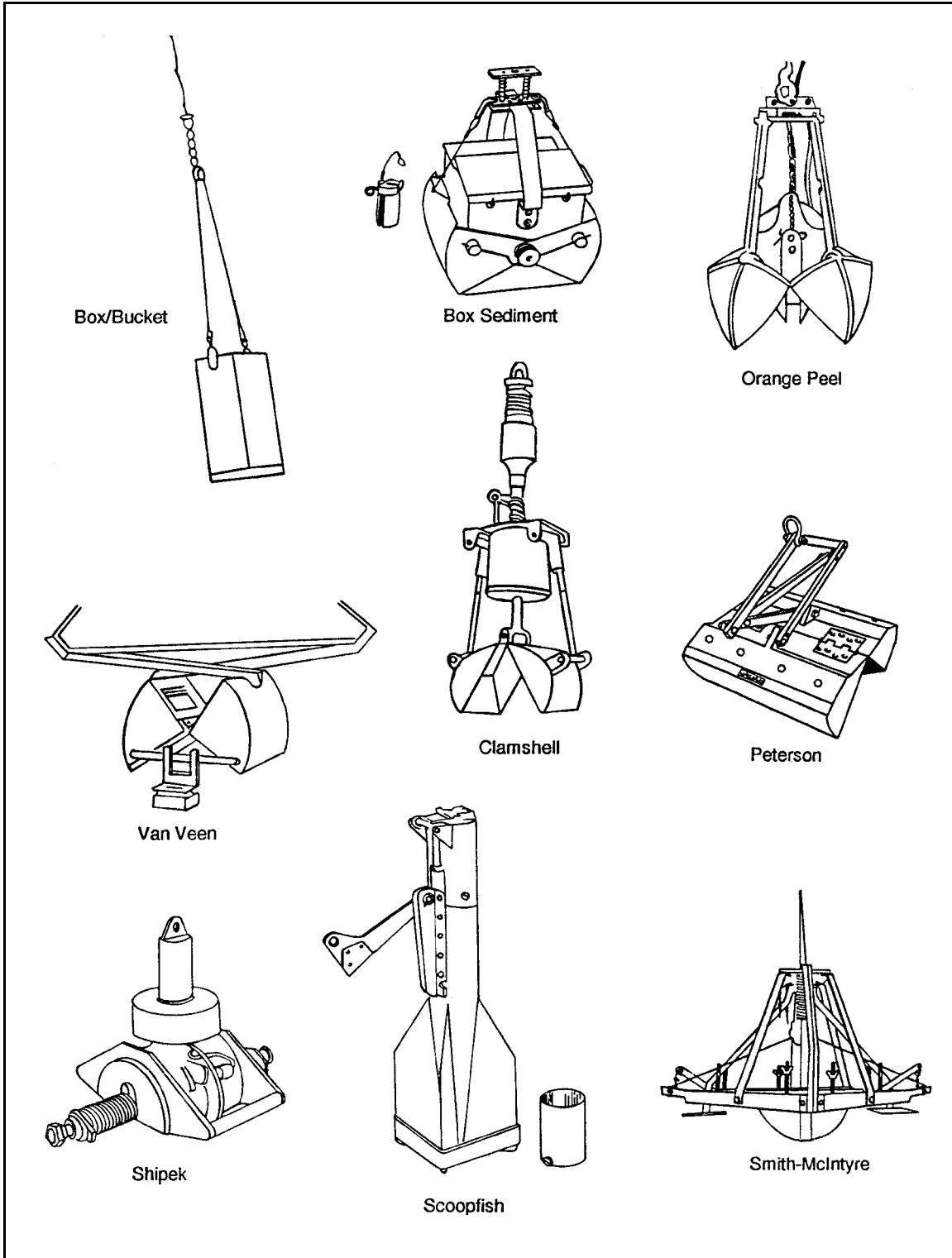

Figure 10-9. Schematic diagrams of several dredges and grab samplers that can be used to obtain disturbed, surficial sediment samples of the seafloor from almost any depth of water. (Figure provided by the U.S. Naval Facilities Engineering Service Center)

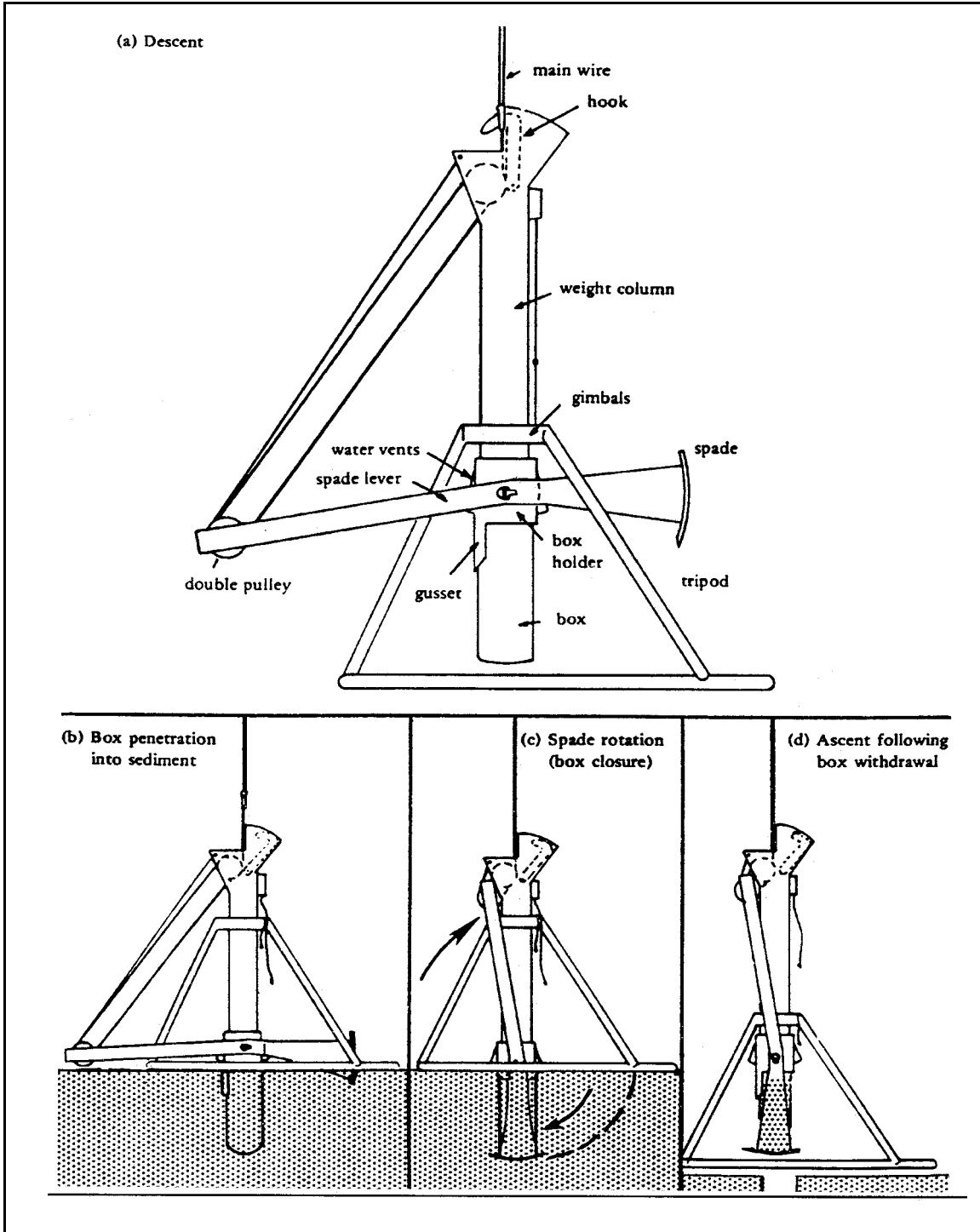

Figure 10-10. Conceptual presentation of the operating sequence of the box corer. (Figure provided by the U.S. Naval Engineering Service Center)

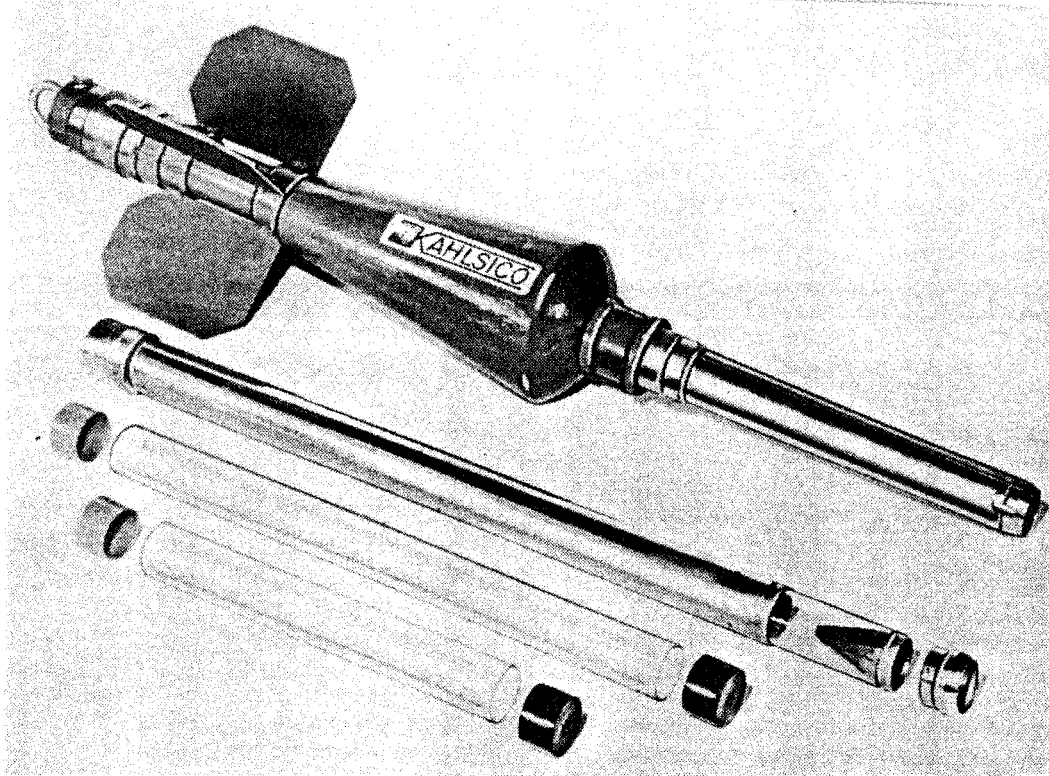

Figure 10-11. Photograph of the Phleger gravity corer. (Figure provided by the U.S. Naval Facilities Engineering Service Center)

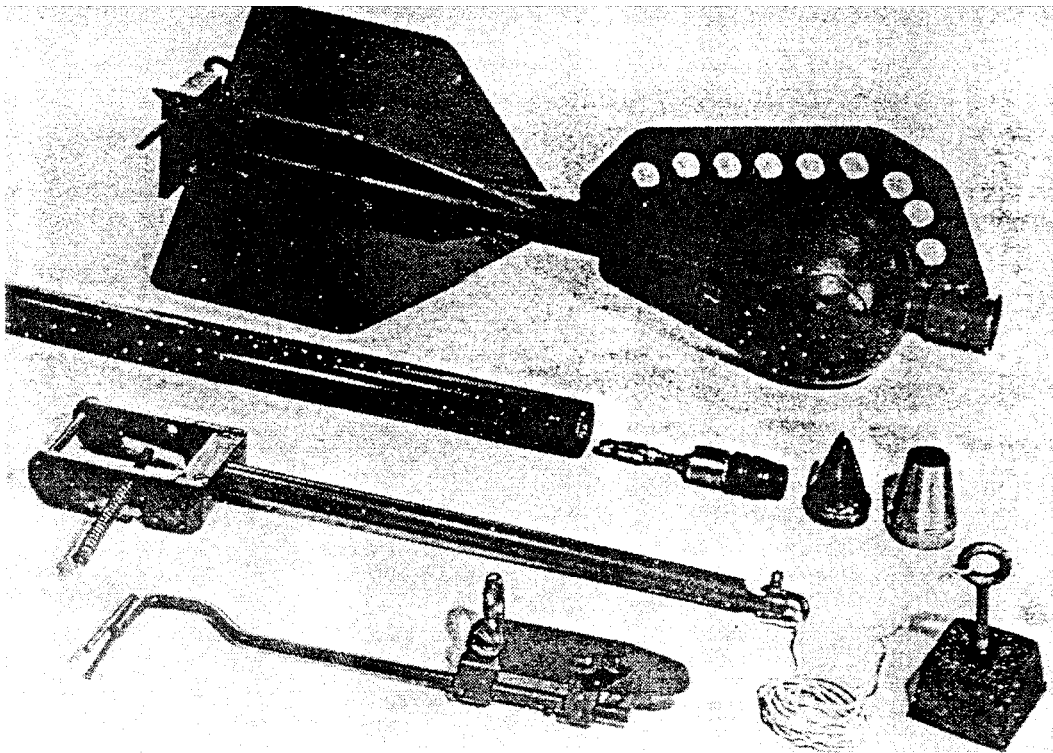
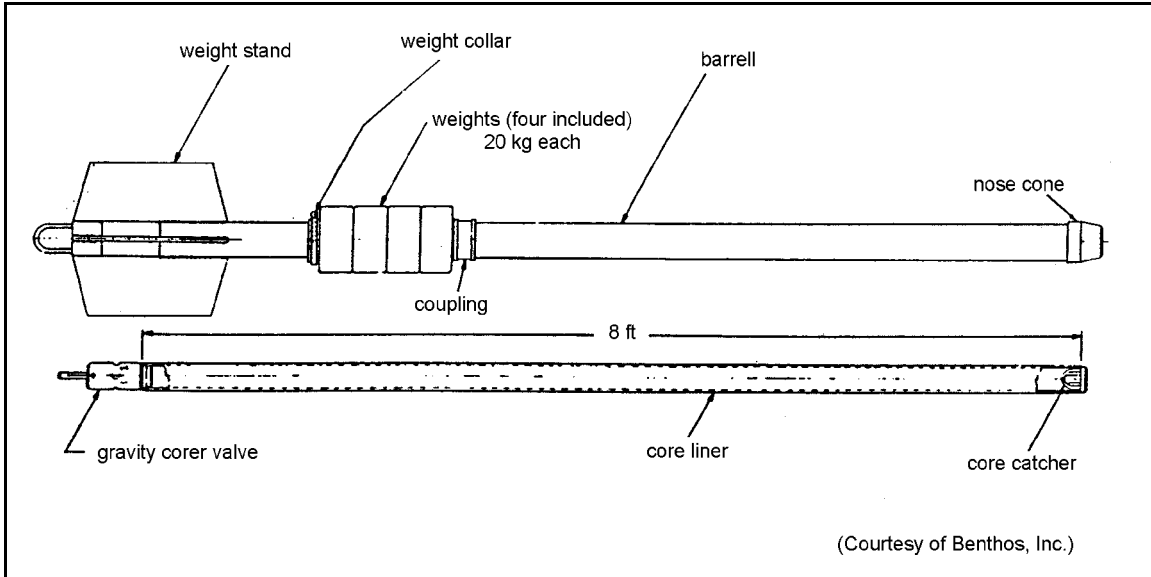

Figure 10-12. Ewing gravity corer. (Figure provided by the U.S. Naval Facilities Engineering Service Center)

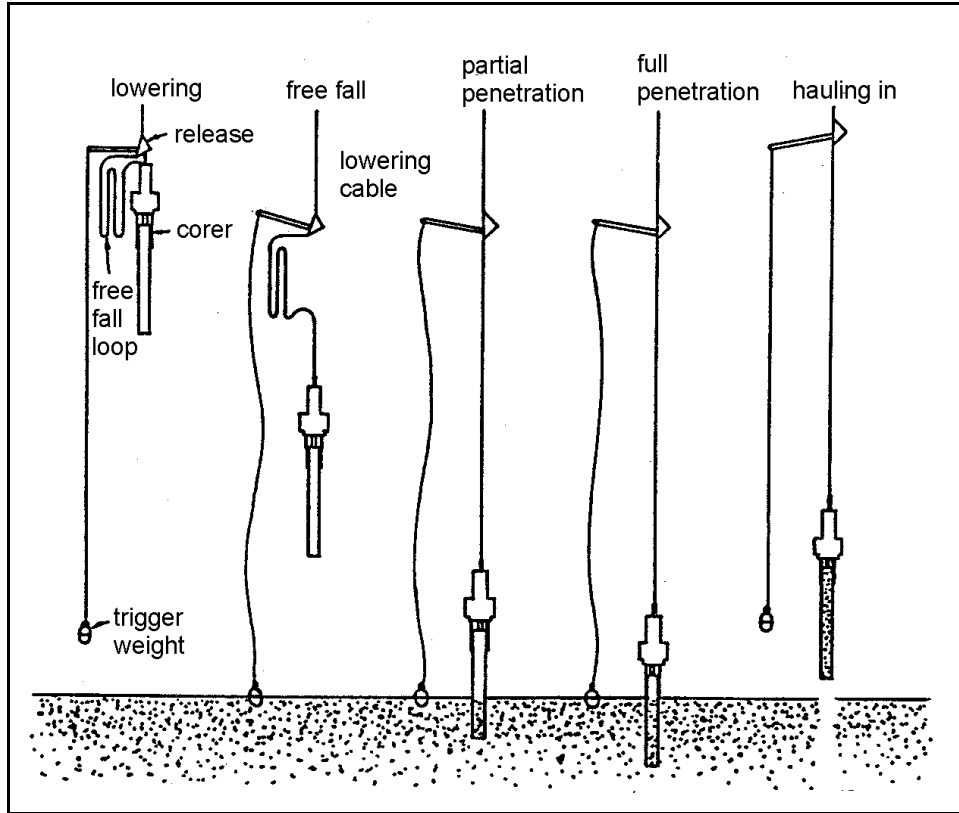

Figure 10-13. Schematic diagram of the trip arm release for operation of the check valve in a valve-type gravity corer. (Figure provided by the U.S. Naval Facilities Engineering Service Center)

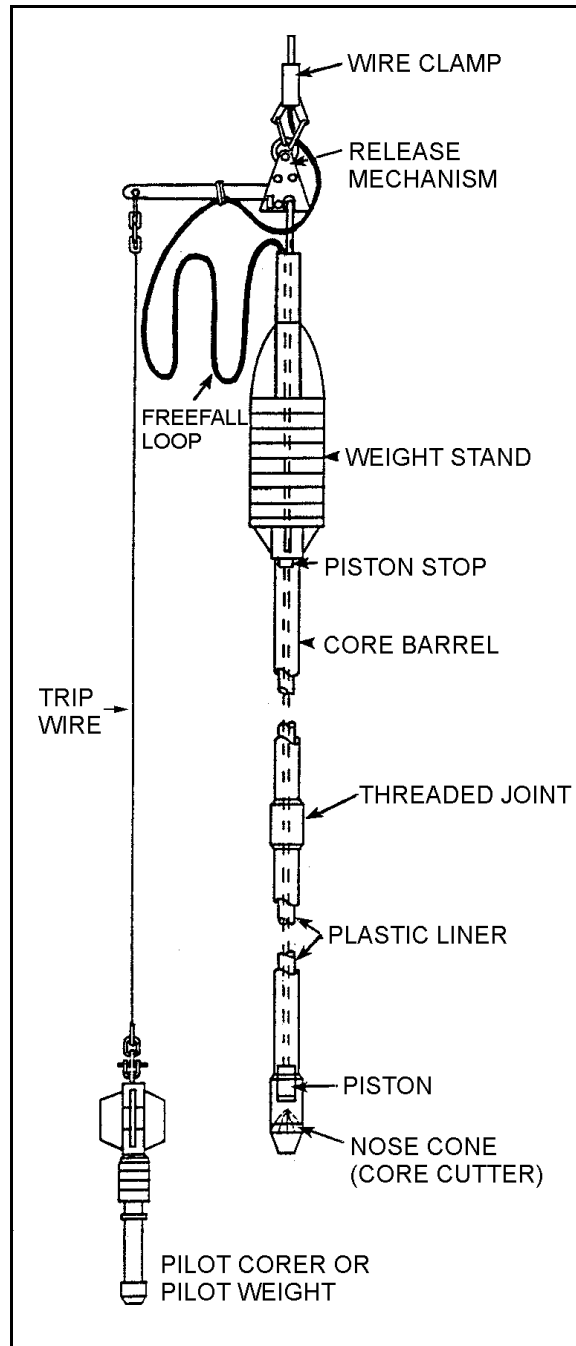

Figure 10-14. Schematic diagram of a typical piston-type gravity corer. (Figure provided by the U.S. Naval Facilities Engineer Service Center)

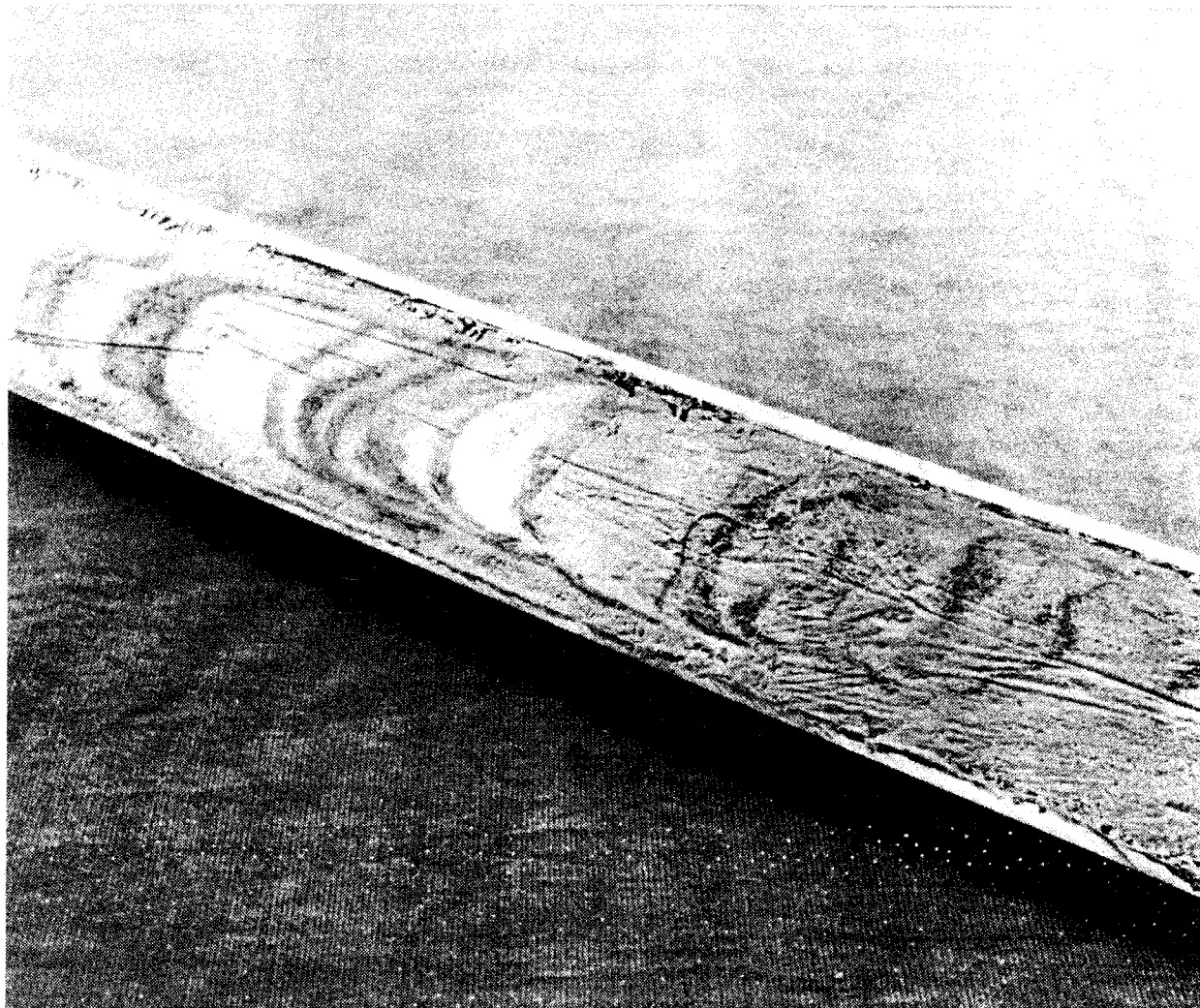

Figure 10-15. Photograph of a disturbed vibratory core. Note that the thin horizontal layers of dark sediment are curved downward due to sampling disturbance. (Figure provided by the U.S. Naval Facilities Engineering Service Center)

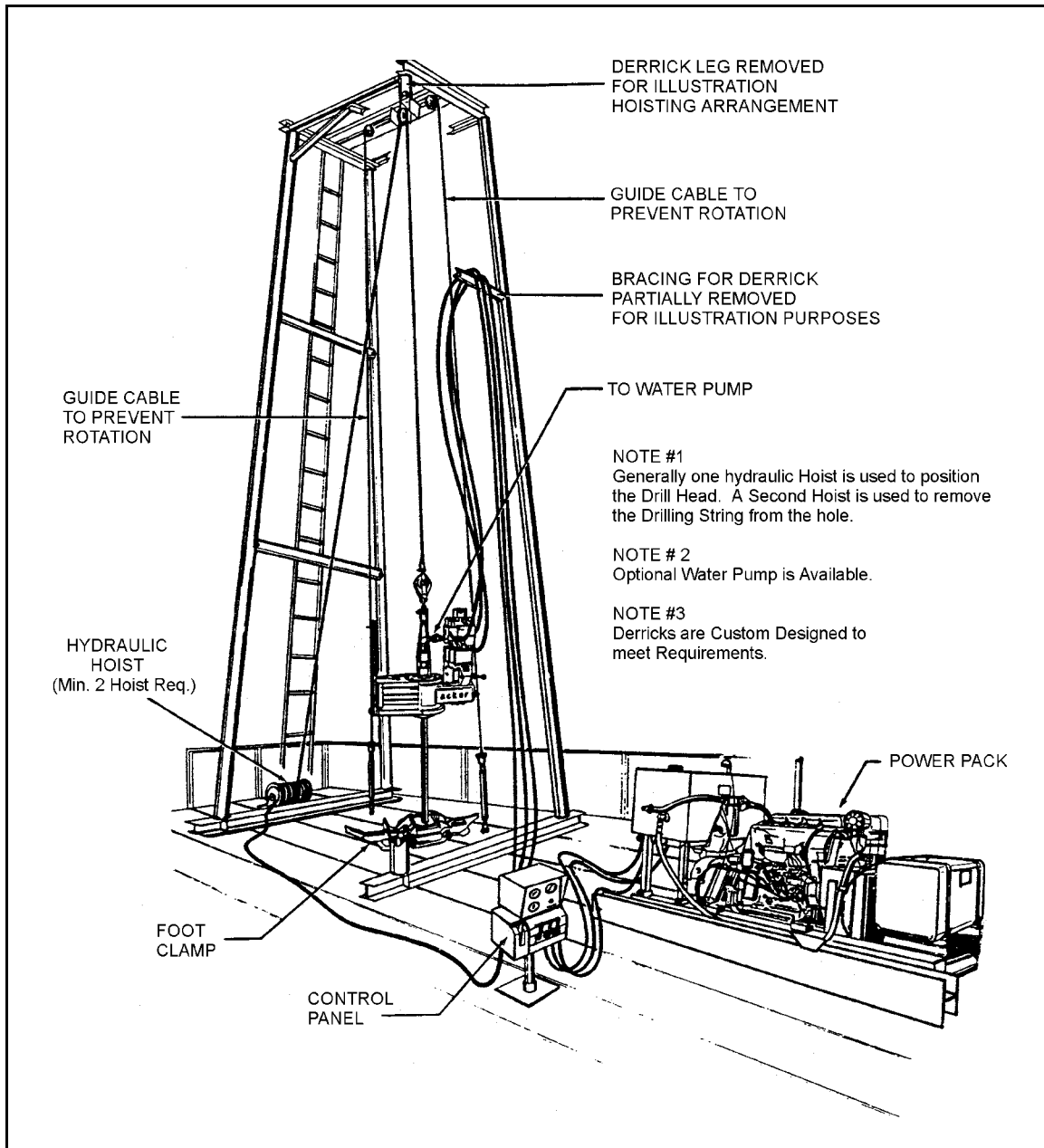

Figure 10-16. Schematic diagram of a custom-designed derrick with a power swivel which is used to minimize the movement of the drill string as the work platform or boat is tossed about by the seas. (Figure provided by the U.S. Naval Facilities Engineering Service Center)

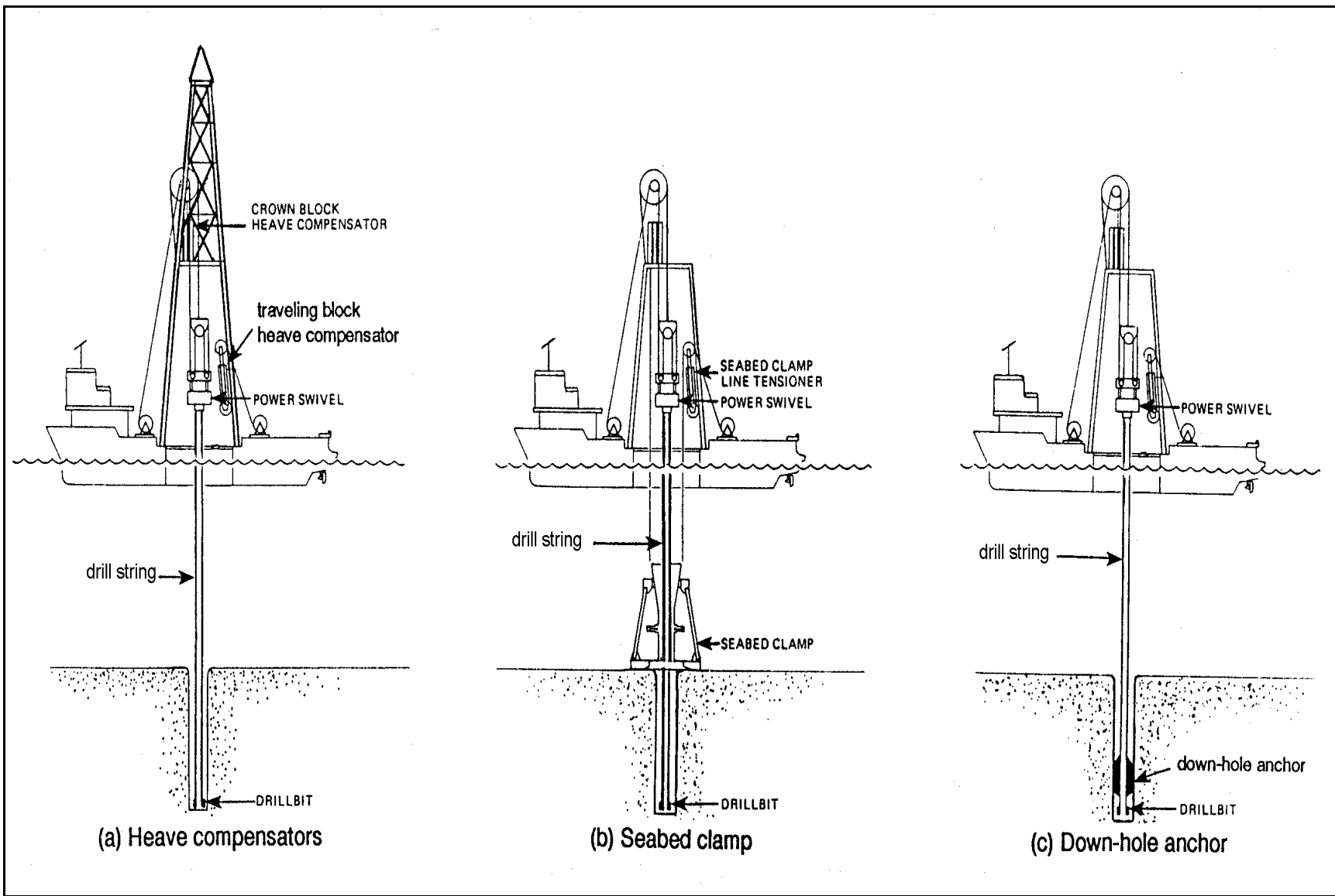

Figure 10-17. A schematic diagram of the three common techniques used to stabilize a drill string against vertical movement of the work platform. (Figure provided by the U.S. Naval Facilities Engineering Service Center)

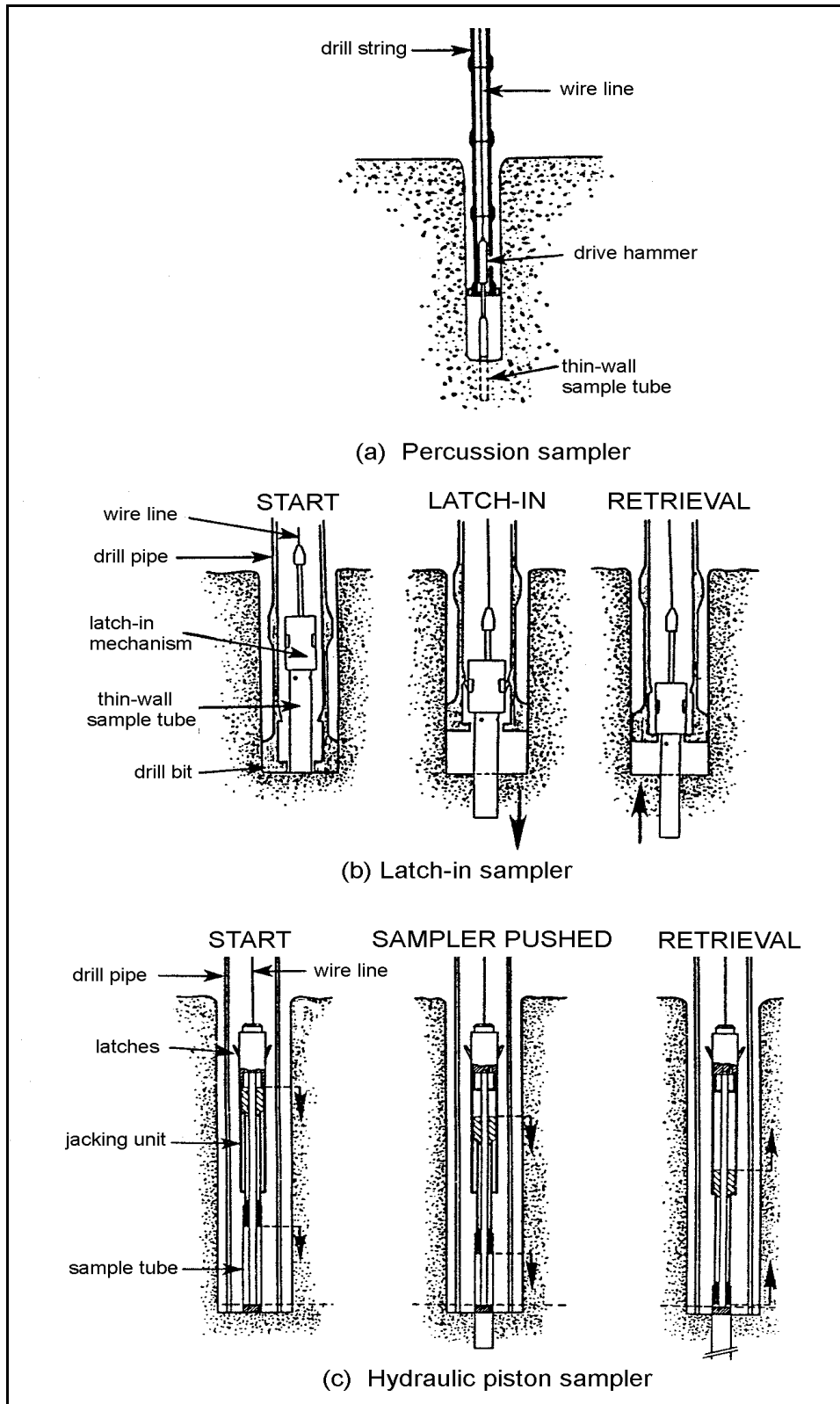
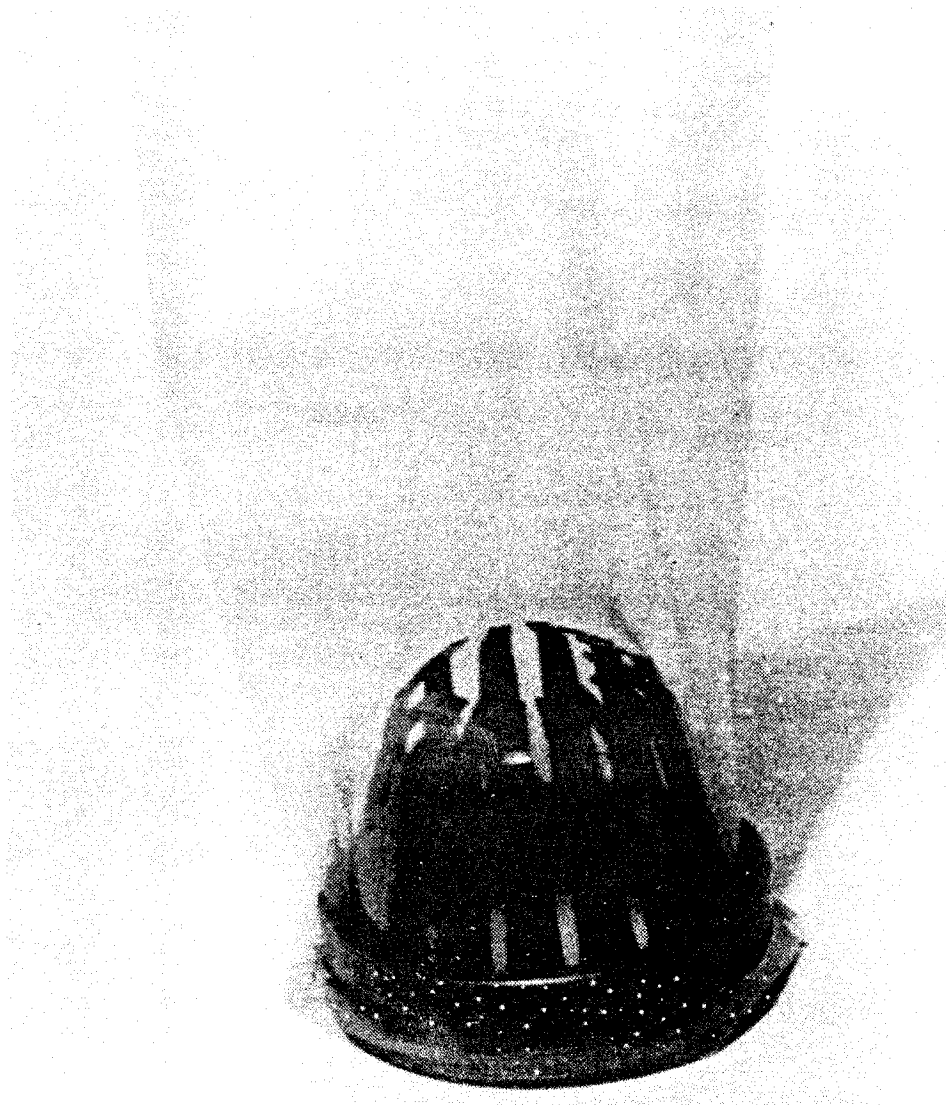

Figure 10-18. Wireline sampling tools which can be used if a motion compensation system is not available. (Figure provided by the U.S. Naval Facilities Engineering Service Center)



(Courtesy of Acker Drill Co.)

Figure 10-19. Photograph of a finger-type sample catcher with a polyethylene sleeve for retaining hard to sample materials. After the sample has been obtained, the bag collapses to help retain the material in the sampling tube. (Figure provided by the U.S. Naval Facilities Engineering Service Center)

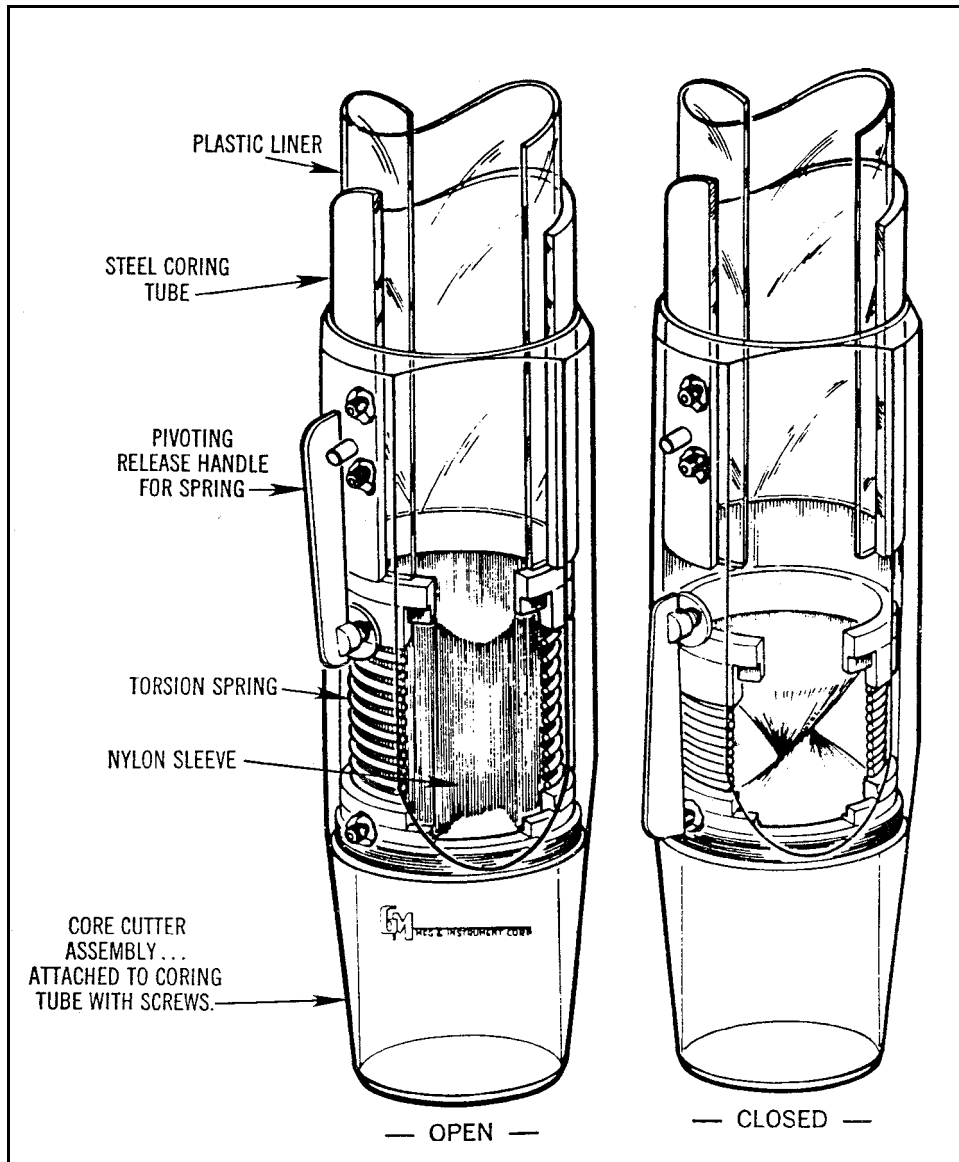

Figure 10-20. Isometric drawing of a core catcher with a sphincter closure to retain the core. (Figure provided by the U.S. Naval Facilities Engineering Service Center)

| | | | |
|--------------------------------------------------------------|------------------------|-----------------------|---------------------|
| PROJECT/CRUISE _____ | | DATE _____ | |
| VESSEL _____ | | | |
| SITE DESIGNATION _____ | | WATER DEPTH _____ | |
| NAVIGATION SYSTEM _____ | COORDINATES _____ | | MEASURED WITH _____ |
| _____ X _____ | Y _____ | ORIGINAL _____ | |
| _____ X _____ | Y _____ | CORRECTION _____ | |
| _____ X _____ | Y _____ | CORRECTED _____ | |
| SAMPLER TYPE | | | |
| <input type="checkbox"/> BOOMERANG | SAMPLER CAPACITY _____ | TIME | |
| <input type="checkbox"/> DIVER CORER | BOX DIMENSIONS _____ | START DOWN _____ | |
| <input type="checkbox"/> GRAB/DREDGE | BARREL LENGTH _____ | ON BOTTOM _____ | |
| <input type="checkbox"/> BOX | FREEFALL LENGTH _____ | START UP _____ | |
| <input type="checkbox"/> GRAVITY-VALVE | TRIP WIRE LENGTH _____ | ON DECK _____ | |
| <input type="checkbox"/> GRAVITY-PISTON | AMOUNT OF WEIGHT _____ | SPEED | |
| <input type="checkbox"/> VIBRATORY CORER | OTHER DETAILS _____ | LOWERING RATE _____ | |
| <input type="checkbox"/> DRILLSTRING | _____ | RETRIEVAL RATE _____ | |
| <input type="checkbox"/> OTHER _____ | _____ | PULLOUT LOAD _____ | |
| SAMPLE DESCRIPTION: _____ | | | |
| CORER PENETRATION DEPTH: _____ | | | |
| SECTION # | | | |
| TOP | LENGTH | DESCRIPTION/CONDITION | |
| | | | |
| | | | |
| | | | |
| | | | |
| | | | |
| | | | |
| | | | |
| | | | |
| | | | |
| | | | |
| REMARKS (WEATHER, ACCIDENTS, EQUIPMENT PROBLEMS, ETC.) _____ | | | |
| _____ | | | |
| _____ | | | |
| _____ | | | |
| _____ | | | |
| _____ | | | |

Figure 10-21. Data log form for an underwater sampling investigation. (Figure provided by the U.S. Naval Facilities Engineering Service Center)

Chapter F-11 Sampling from Test Pits, Trenches, Accessible Borings, or Tunnels

11-1. Introduction

a. Accessible excavations. For certain geotechnical investigations, it may be necessary to provide excavations that are large enough to permit entrance by a person for inspection and sampling of subsurface materials in situ. Hvorslev (1949) called these excavations “accessible explorations.” Accessible excavations are those excavations that are made with machinery other than conventional drilling and sampling equipment. These excavations include test pits or trenches, large-diameter borings, caissons, tunnels, shafts, drifts, or adits.

Accessible excavations expose large areas of subsurface materials that permit direct examination of the in situ conditions, observation of slope stability or groundwater conditions, fault evaluation studies, recovery of large undisturbed samples, in situ testing, installation of instrumentation, or evaluation of abnormalities. Accessible excavations also offer an excellent means for evaluating excavation methods or the effects of blasting while providing an opportunity to confirm data obtained from conventional boring and sampling programs. Accessible explorations may be the only practical method of obtaining accurate information regarding borrow materials, riprap and concrete aggregate, or test fills. The data in Table 11-1 suggest several types of accessible excavations as well as procedures and limitations for each.

b. Advantages and disadvantages. Before a decision is rendered that accessible excavations are needed as an integral part of the geotechnical investigation, the advantages and disadvantages of these excavations must be considered.

Accessible excavations provide the most reliable and detailed information of soil and rock along a specific horizontal or vertical line. Accessible excavations also permit direct examination, sampling, or in situ testing of the formation. Although the costs of accessible excavations are rather high, the costs are often small in comparison to construction costs where geologic information is meager or insufficient to forewarn of adverse conditions.

Examination, sampling, or in situ testing of the formation in accessible excavations is usually more expensive than for conventional in situ testing and sampling operations. The depths of accessible excavations are usually limited to about 6 to 9 m (20 to 30 ft) or to the water table. For greater depths, the costs and difficulties of excavating, cribbing, and pumping generally make accessible excavations impractical and uneconomical. Because longer periods of time are required to excavate the formation and to take the necessary safety precautions, disturbance caused by exposure of the formation may be greater for an accessible excavation than the disturbance caused by conventional sampling and in situ testing operations. The disturbance is caused by a change of water content, stress reduction, swelling or plastic flow, expansion of gas or air trapped in the soil, and oxidation or disintegration of the material.

c. Use. During the reconnaissance and feasibility stages of an investigation, representative, disturbed or undisturbed soil samples are necessary to estimate the engineering properties of materials to be used for construction of proposed embankment dams, canal linings, roads, etc. Unfortunately, representative samples of certain soils, including very soft cohesive soils, cohesionless soils, and gravelly soils, are very difficult and frequently impossible to obtain using conventional drilling and sampling techniques. The most feasible method for obtaining samples of these materials may be the use of test

pits, trenches, shafts, or tunnels. Although only highly disturbed or remolded samples can sometimes be obtained, these excavations often yield excellent information regarding stratification and density of the formation as well as potential difficulties which may be encountered during construction. To fully utilize the data that can be obtained from accessible explorations, excavations should be designed and data collected under the supervision of geotechnical personnel who fully understand the purpose of the exploration program and how the data will be used for design and analysis.

11-2. Excavation

The depth of an accessible excavation dictates the method of excavation. Test pits and trenches may be excavated by hand or by conventional earth-moving equipment. Accessible borings may be drilled with special-purpose drilling rigs. Shallow pits dug to depths up to 1.2 m (4 ft) in stable soil usually require no shoring; for deeper excavations or pits in unstable soil, shoring must be used (EM 385-1-1). Excavations extending below the water table require control of the groundwater. In impervious or relatively impervious soils, groundwater can be controlled by pumping directly from a sump or drainage ditch in the pit. If the pit extends below the water table in sand or silt, dewatering by means of a well-point system may be necessary to ensure dryness and stability of the pit. If seepage forces are great, "blowouts" in the bottom or sides of the pit can result.

a. Test pits. Test pits are commonly used for exposing and sampling foundation and construction materials. The test pit must be large enough to permit detailed examinations of the material in situ to be conducted or to obtain large, undisturbed samples as required by the investigation. Typically, the plan view of the pit will be square, rectangular, or circular. The minimum dimensions of the pit are on the order of 0.9 by 1.5 m (3 by 5 ft) or 1.2 by 1.8 m (4 by 6 ft); it should be noted that these dimensions are net dimensions at the bottom of the excavation and do not include the space required for shoring or sloping the walls of the excavation in unstable or soft materials or for deep excavations.

Test pits may be dug by hand or by machine. Power excavating equipment, such as backhoes, trenching machines, draglines, clamshells, large-diameter bucket augers, or bulldozers, may be used for rough excavation of test pits to a distance of about 0.6 m (2 ft) from the proposed sample. The final excavation of samples must be carefully made with hand tools, such as picks, shovels, trowels, and buckets. Deeper pits must be started with sufficient dimensions to allow for shoring or sloping of the sides to prevent caving. The depth of the pit and the type and condition of the soil generally dictate the type of support system, such as sheeting, sheet piling, bracing, shoring, or cribbing, which is needed. General guidance for design of a support system is presented by Winterkorn and Fang (1975). Shoring must be installed progressively as the pit is deepened. The space between the walls of the pit and the support system should be kept to a minimum; this space may be backfilled with hay or excelsior.

Care must be exercised in excavating the area near the intended sample or test. The limits of the sample should be outlined with a pick and shovel. The material near the proposed sample should be excavated to a depth about 25 to 50 mm (1 to 2 in.) below the bottom of the intended sample. The excavated zone should be trimmed relatively level and be sufficiently large to allow adequate working space for obtaining the sample. A pedestal of soil, roughly the shape of the sample and about 25 mm (1 in.) larger in each dimension, should be left undisturbed for final trimming.

Excavated material should be placed at a horizontal distance from edge of the pit not less than the anticipated maximum depth of the pit. Excavated material should be placed in orderly fashion around the pit to facilitate logging of the material. Wooden stakes can be used to mark the depth of the excavated material. Samples for water content determination should be obtained in a timely manner to prevent

drying of the material. Care should be taken to ensure that pits are properly ventilated to avoid carbon monoxide or poisonous gases. If necessary, a ventilation fan should be used to force air into the pit; the exhaust of any gasoline or diesel-powered equipment should be vented away from the pit.

b. Test trenches. Test trenches can be used to perform the same function as test pits but offer one distinct advantage, i.e., trenches provide a continuous exposure of the continuity and character of the subsurface material along a given line or section. Test trenches can be excavated with ditching machines, backhoes, bulldozers, or pans, depending upon the required size and depth of the trench. The minimum bottom width of a trench is about 0.6 to 0.9 m (2 to 3 ft), although this dimension is sometimes greater because of the use of power equipment, such as bulldozers and pans. As the trench is deepened, the sides must be sloped, step cut, or shored to prevent caving, similar to the procedures that must be used for excavating deep test pits. Final excavation in the vicinity of the intended sample must be performed carefully by hand.

c. Accessible borings. Although accessible borings, including shafts, tunnels, drifts, and adits, are not used extensively today because of the high costs of drilling operations, large accessible borings are sometimes required for inspection, sampling, or testing of selected strata by geotechnical personnel. The minimum diameter for the boring is about 0.6 m (2 ft), although larger dimensions may be necessary to provide ample working space. The depths of accessible borings may be considerably deeper than the depths of test pits or trenches. Because of the unknown conditions that may be encountered underground, a means for detecting poisonous gas should be provided before personnel are allowed to enter the accessible boring. Air should be ducted to the bottom of the hole.

Power-auger drills are frequently used to advance boreholes in most soils and soft rock (see Chapters 7 and 8). Steel-tooth single tube core barrels (calyx-coring equipment) are sometimes used when hard, stiff, or frozen soil or rock is encountered. A shot or calyx hole is drilled with a large heavy-walled steel tube that is equipped with a slotted bit made of mild steel. The top of the single-tube barrel is attached to heavy drill pipe by a thick circular head plate. The head plate has a hole at its center for the passage of drilling fluid. A deflector plate which is used to deflect the steel shot and drilling fluid to the periphery of the sample is located immediately below the head plate. A sludge barrel is sometimes attached above the core barrel to catch the cuttings. Two types of bits are commonly used. One type of bit consists of a second tube which is welded to the interior wall of the lower portion of the core barrel. The other type of bit consists of a heavy thick-walled pipe which is welded to the base of the barrel. Slots are cut into the bit to facilitate the movement of shot to the bottom and the outside of the bit. The thickness of the shot bit may vary from about 2.2 to 3.5 cm (7/8 to 1-3/8 in.). A core catcher is not provided. The core can be recovered by a lifting hook which is inserted into the sample through a hole that has been drilled in the center of the core. The core can also be recovered by using a special core lifter which has been attached to the core barrel; the core lifter works similarly to a conventional core catcher. The core barrel may also have provisions for placement of powder charges and conduit for blasting wires which may be necessary to separate the core from the formation.

During drilling operations, very hard steel shot are carried by the wash water through the annulus formed by the core and the core barrel to the slotted bit. As the barrel is rotated, shot is wedged beneath and around the bit and crushed into abrasive particles. Some of the shot may become embedded in the bit, which enhances the cutting action. The rate of feeding the shot and the flow of water in the borehole are critical factors. If too much shot is introduced, the bit will ride on the shot. If too little shot is used, the advancement of the borehole is inefficient. Likewise, too much water circulation will carry the shot away from the bit, whereas too little circulation will not remove the cuttings effectively. The cuttings are caught by the sludge barrel which is located above the corebarrel as they drop from suspension.

Casing must be installed in boreholes more than 1.2 m (4 ft) deep before anyone is allowed access to the hole (EM 385-1-1). Corrugated steel pipe is an economical, lightweight casing for relatively stable soils above the water table; in deep borings or in soft materials, heavy steel casing may be required. The borehole can be logged from cuttings as the hole is advanced or from samples or visual examination of the walls and bottom of the borehole at regular intervals. Windows may be cut in the casing for inspection, sampling, or testing of the materials along the sidewalls of the hole as required by the testing program.

An exploratory tunnel is usually rectangular shaped; minimum dimensions are typically of the order of 1.5 m (5 ft) wide by 2.1 m (7 ft) high, although these dimensions may be increased to meet the requirements of power-excavation equipment. The excavation of tunnels, which is usually very slow and expensive, may be conducted by mucking machines or by drilling and blasting. If drilling and blasting are used to advance the tunnel, the disturbed material caused by blasting should be carefully removed to ensure that undisturbed samples are obtained. The design of the support system for the tunnel should be made by a qualified, experienced professional.

11-3. Sampling and Testing

The following paragraphs describe various methods of obtaining soil samples from accessible excavations, including test pits, trenches, and accessible borings.

a. Undisturbed samples. Undisturbed samples are taken to preserve as closely as possible the in-place density, stress, and fabric characteristics of the soil. Although excavating a column of soil may relieve in situ stresses to some degree, it has been demonstrated that hand sampling of certain soils, such as stiff and brittle soils, partially cemented soils, and soils containing coarse gravel and cobbles, is perhaps the best and sometimes the only method for obtaining any type of representative sample. Large block samples of these materials are suitable for certain laboratory tests, although smaller samples should be used whenever the size of the sample does not adversely affect the test results. During handling and shipping of undisturbed samples, it is important to minimize all sources of disturbance including vibration, excessive temperature changes, and changes of water content.

(1) *Cylinder with advanced trimming.* Before sampling operations are begun, prepare the surface of the soil to be sampled as described in paragraph 11-2. After a pedestal of soil has been excavated, center the cutting edge of the sampling cylinder on top of the pedestal. To obtain a sample, trim the soil for a short distance below the cutting edge of the cylinder and then advance the cylinder by applying a slight downward pressure. Alternating trimming and advancing of the cylinder should be continued until the top of the sample extends approximately 12 mm (1/2 in.) above the top of the cylinder. During the trimming and sampling procedure, the sample should be trimmed as closely as possible to its final diameter without actually cutting into the intended sample; the final cutting of the sample is made by the advancement of the cutting edge of the cylinder without wiggling or change in direction. When sufficient material has been extended above the top of the cylinder, the sample should be cut from the pedestal of soil below the bottom of the cylinder, trimmed flush at both ends of the cylinder, and sealed for shipment to the laboratory.

The GEI sampler (Figure 11-1) incorporates the advanced trimming technique for obtaining a soil sample. The unique feature of the GEI device is a tripod holder that minimizes wiggling or change of direction during the advancement of the tube. Marcuson and Franklin (1979) reported that very high-quality samples of dense Savannah River sand were obtained by using the GEI sampling apparatus. The test data indicated that although only modest differences in sample densities existed between samples

obtained with the GEI sampler and a fixed-piston sampler, a dramatic difference in resistance to cyclic loading was observed. Marcuson and Franklin concluded the differences of cyclic strengths were due to better preservation of the in situ structure.

(2) *Block or cube samples.* To obtain a cube or block sample, prepare the surface of the soil to be sampled as described in paragraph 11-2. Excavate a pedestal of soil that is slightly larger than the dimensions of the box or container into which the sample is to be placed. A knife, shovel, trowel, or other suitable hand tools should be used to carefully trim the sample to about 25 mm (1 in.) smaller than the inside dimensions of the box. As the sample is trimmed to its final dimensions, cover the freshly exposed faces of the sample with cheesecloth and paint with melted wax to prevent drying and to support the column of soil. After the block of soil has been trimmed but before it has been cut from the underlying material, place additional layers of cheesecloth and wax to form a minimum of three layers, as presented in ASTM D 4220-83 (ASTM 1993). A 1:1 mixture of paraffin and microcrystalline wax is better than paraffin for sealing the sample. A sturdy box should be centered over the sample and seated. Loose soil may be lightly tamped around the outside of the bottom of the box to align the box with respect to the soil sample and to allow packing material such as styrofoam, sawdust, or similar material to be placed in the voids between the box and the soil sample. Hot wax should not be poured over the sample. After the packing material has been placed around and on top of the sample and the top cover for the box has been attached, cut or shear the base of the sample from the parent soil and turn the sample over. After the sample has been trimmed to about 12 mm (1/2 in.) inside the bottom of the box, the bottom of the sample should be covered with three alternating layers of cheesecloth and wax. The space between the bottom of the sample and the bottom of the box should be filled with a suitable packing material before the bottom cover is attached. The top and bottom of the box should be attached to the sides of the box by placing screws in predrilled holes. The top and bottom should never be attached to the sides of the box with a hammer and nails because the vibrations caused by hammer blows may cause severe disturbance to the sample. Figure 11-2 shows block samples in various stages of trimming and sampling.

Tiedemann and Sorensen (1983) suggested an alternative method for trimming block samples. They reported that soils sampled successfully using the chain-saw method included a weathered shale between layers of sound sandstone and a highly slickensided, desiccated fat clay; they stated that it had not been possible to sample either of these soils using conventional hand-trimming methods. Tiedemann and Sorensen also reported that the chain-saw method was less tedious and less time-consuming than conventional hand-trimming methods. The chain-saw technique of trimming samples was reported to be three to four times faster than conventional hand-trimming techniques. It was stated that the chain saw was of a standard design except that carbide tips had been brazed to the cutting teeth to enhance the cutting of the soil sample.

Block samples to be tested at the site should be cut to sizes dictated by the individual tests to be performed. Samples to be used for water content determination may be broken from the corner of large block samples. Samples to be tested at the site may be coated with a thin brush coating of wax or reinforced with cheesecloth and wax, as necessary, to prevent the sample from drying or to prevent damage caused by excessive handling.

(3) *Push samplers.* Several hand-operated open- or piston-samplers are available for obtaining undisturbed samples from the ground surface as well as from the walls and bottom of pits, trenches, or accessible borings. The hand-operated open sampler consists of a thin-wall sampling tube affixed to a push rod and handle. The piston sampler is similar to the open sampler except a piston is incorporated into the design of the device. The procedures for operating these samplers are similar to the procedures

for open samplers or piston samplers in rotary drilling operations, as described in Chapter 6. Hand-operated push samplers may be used to obtain samples in soft-to-medium clays, silts, and peat deposits at depths of 6 to 9 m (20 to 30 ft) or more.

b. Disturbed samples. Disturbed samples may be obtained from test pits, trenches, or accessible borings. Disturbed, representative samples of soil are satisfactory for certain laboratory tests including classification, water content determination, and physical properties tests. For certain soils such as very soft clays or gravelly soils, undisturbed samples may be impossible to obtain. Provided that the unit weight and moisture content of the soil in place can be estimated or are known, it may be permissible to perform certain laboratory tests on specimens remolded from samples of disturbed material.

To sample a particular stratum, remove all weathered and mixed soil from the exposed face of the excavation. Place a large tarpaulin or sheet of plastic on the bottom of the test pit or accessible boring. With a knife or shovel, trench a vertical cut of uniform cross section along the full length of the horizon or stratum to be sampled. The width and depth of the cut should be at least six times the diameter of the largest soil particle sampled. Collect the soil on the tarpaulin. All material excavated from the trench should be placed in a large noncorrosive container or bag and preserved as a representative sample for that stratum. An alternative sampling procedure consists of obtaining a composite sample of two or more soil strata; if samples from certain strata are omitted, an explanation must be reported under "Remarks" on the log form. Samples obtained for determination of water content may be placed in pint glass or plastic jars with airtight covers; the sample should fill the container.

To obtain samples from quarries, ledges, or riverbank sands or gravels, use the procedures for obtaining disturbed samples which were discussed in the preceding paragraphs. Channel the face vertically to obtain samples representative of the formation. Take care to ensure that overburden or weathered material is not included as a portion of the sample.

11-4. Preservation of Samples and Test Records

a. Preservation, shipment, and storage of samples. Undisturbed samples to be tested in the laboratory must be packaged to prevent any disturbance that will affect test results. Block samples or samples obtained by the trimming and advancement technique must be marked and stored in a vertical orientation. Disturbed samples should be placed in a bag or a corrosion-resistant container and preserved as a representative sample for the particular stratum of material. If a container is used, identification of the contents should be marked directly on the exterior of the container; do not mark the lids of containers because they may be inadvertently interchanged. If the natural water content of the sample is to be preserved, the container must be waterproof. For shipment, each sample should be packaged to prevent damage, such as excessive vibrations, loss or mixing of materials, temperature extremes, or change of water content, which could affect test results. Additional details regarding the preservation of materials for shipment and storage are presented in Chapter 13 and in ASTM D 4220-83 (ASTM 1993).

b. Records. Although there is no single procedure for recording the data, the record should reflect all details of the investigation. Pertinent data, including the name of the project, job or contract number, samples obtained, tests conducted, etc., must be recorded on data sheets. The methods used for excavation along with a description of the equipment, an observation of procedures, and an evaluation of the effectiveness of excavation procedures are necessary to permit the evaluation of the overall program. The location or position of each borehole, test pit, trench, sample, or test should be clearly located horizontally and vertically with reference to an established coordinate system, datum, or permanent monument. The depth of each major change in soil character and a detailed description of each major

stratum should be recorded. Be sure to note stratifications, structural and textural features, color, hardness, density, grain size, percent by volume of cobbles and boulders, etc., of the stratum. Include methods of stabilizing the excavation. Maps or sketches with accurate descriptions and photographs are extremely helpful for documenting the record of the site investigation. Each soil sample or test should be numbered. The number and type of sample containers should also be shown on the appropriate data sheet(s). If field tests are performed, a data sheet for each test must be prepared giving pertinent data such as weight, volume, density, and water content. All data sheets should be dated and signed by the crew chief or technician performing the operation. Additional guidance for the preparation of field records is given in Chapter 13.

11-5. General Safety Considerations

Several safety considerations with respect to the inspection and sampling or testing of formations exposed by excavations for test pits, trenches, and accessible boreholes or tunnels should be addressed. Although the accompanying list does not address every situation, the suggestions can be used as general guidance to develop a checklist of safety considerations for each site investigation.

- Prior to conducting any excavation, underground installations such as gas, telephone, water, and electric lines must be located and plainly staked.
- Shallow, i.e., less than 1.2 m (4 ft), test pits and trenches in stable soil can generally be excavated without support of the walls. However, a support system, i.e., sheet piling, bracing, shoring, and/or cribbing, or sloping walls is required for excavations deeper than 1.2 m (4 ft) (EM 385-1-1). The support system must be designed by a professional engineer experienced in that type of work.
- Before entering a test pit or trench, inspect the sidewalls and install cribbing or shoring or slope the wall of the excavation, if necessary. Remove loose material that could fall into the excavation.
- Provide ladders, stairs, or ramps, as necessary, to access the pit or trench. For boreholes, a cage or boatswain chair should be used to lower personnel into the hole. The chair should have two lines; the second line is used as a safety line.
- The test pit or borehole should be properly ventilated. Exhaust gases from engines should be directed away from the air intake. A means for detecting poisonous gas should also be provided.
- Groundwater (surface water) should not be permitted to accumulate in excavations. After rainstorms, excavations should be inspected by a qualified person to assess the sidewalls for possible slides or cave-ins; shoring should be added or changed, as necessary.
- To prevent a hazardous loading condition that could trigger a slide, the material excavated from a test pit or trench should be placed at a distance from the edge of the excavation not less than 1.2 m (4 ft) or the depth of the pit or trench, whichever is greater.
- Large-diameter borings or shafts should be cased. In stable soils above the groundwater table, corrugated pipe is an economical method. For deep borings or for boreholes in soft, unstable soils, thick-walled steel pipe may be required. Inspection and sampling or in situ testing of the formation may be conducted using holes cut in the wall of the pipe.

EM 1110-1-1804

1 Jan 01

- The support system for the walls and roof of a tunnel should be designed by a professional engineer experienced in that type of work.
- Fences, barricades, covers, or warning lights should be provided around excavations, as necessary, to protect pedestrians, livestock, or vehicular traffic.
- Temporary excavations should be backfilled as soon as possible after the work has been completed.

Table 11-1
Accessible Excavations (after U.S. Department of the Interior 1986)

| Accessible Excavation | Procedure | Limitations | Comments |
|-----------------------|------------------------------------------------------------------------------------------------------------------------------------------------------------------------------------------------------------------------------------------------------------------------|-------------------------------------------------------------------------------------------------------------------------------------------------------------------------------------|----------------------------------------------------------------------------------------------------------------------------------------------------------------------------------------------------------------------------|
| Test pit | Excavate a rectangular or square pit by hand or power equipment. Minimum dimensions are of the order of 1 by 1-1/2 m (3 by 5 ft). | Economical limit of depth is about 6 to 9 m (20 to 30 ft) or to the water table. If deeper than 1.2 m (4 ft), support or slope the walls of the excavation. | Samples from a test pit are usually more expensive than samples obtained from conventional drilling and sampling operations. Sampling by hand may be the only method of obtaining representative samples of certain soils. |
| Trench | Excavate a rectangular or trapezoidal (cross section) trench by hand or with power equipment. The minimum dimension of the excavation should not be less than 1 to 2 m (3 to 6 ft) wide). The length may be extended as required. | Depth of trench is usually fairly shallow, but may be 6 to 9 m (20 to 30 ft) or to the water table. If deeper than 1.2 m (4 ft), support or slope the walls of the excavation. | Provides a continuous two-dimensional soil profile. This method is perhaps the most economical and comprehensive technique for shallow explorations of foundation, borrow, or aggregate material. |
| Accessible boring | Special purpose drilling equipment, such as large-diameter bucket augers, may be used to drill accessible boreholes to a depth of about 30 m (100 ft). The minimum diameter is about 0.6 m (2 ft), although a larger diameter may be required for adequate work space. | Accessible boreholes deeper than 1.2 m (4 ft) should be cased with steel pipe. Holes may be cut into the pipe to permit inspection and sampling of the sidewalls of the excavation. | If power equipment is available and the area is accessible, large-diameter boreholes can be made more rapidly and at less cost than excavating test pits by hand methods. |
| Tunnel | Excavate a rectangular-shaped tunnel by hand or with power equipment. Minimum dimensions are of the order of 1.5 by 2.1 m (5 by 7 ft), although the dimensions may be increased when power mucking and hauling equipment are used. | Tunneling is expensive and therefore should be used only under special conditions. The roof and walls of the tunnel require a support system. | Must provide underground lighting and ventilation system. |

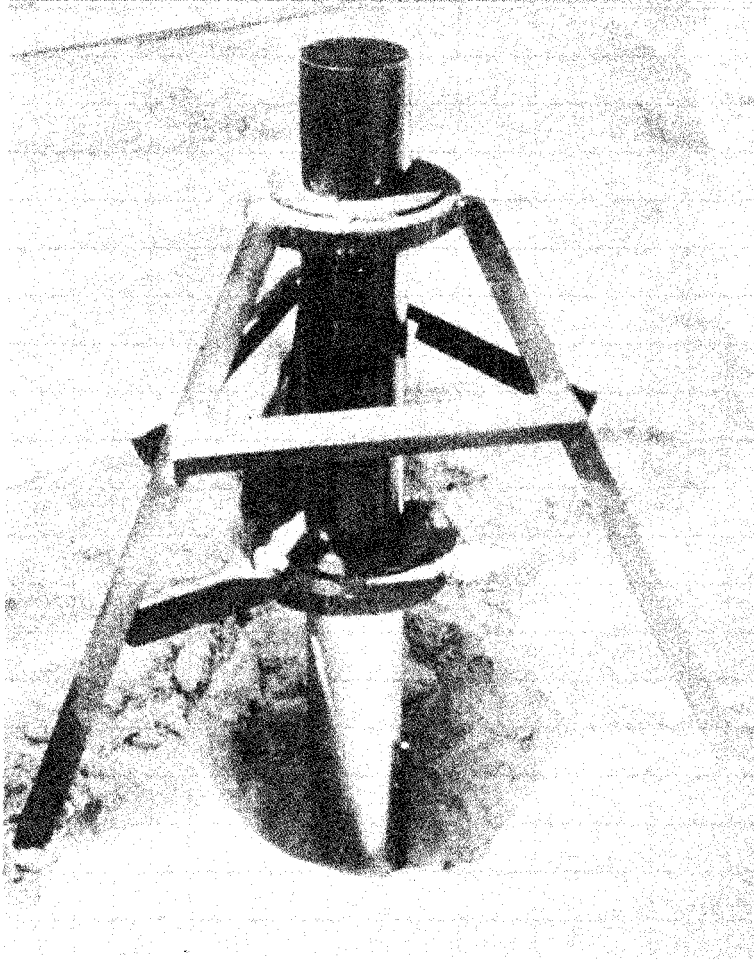
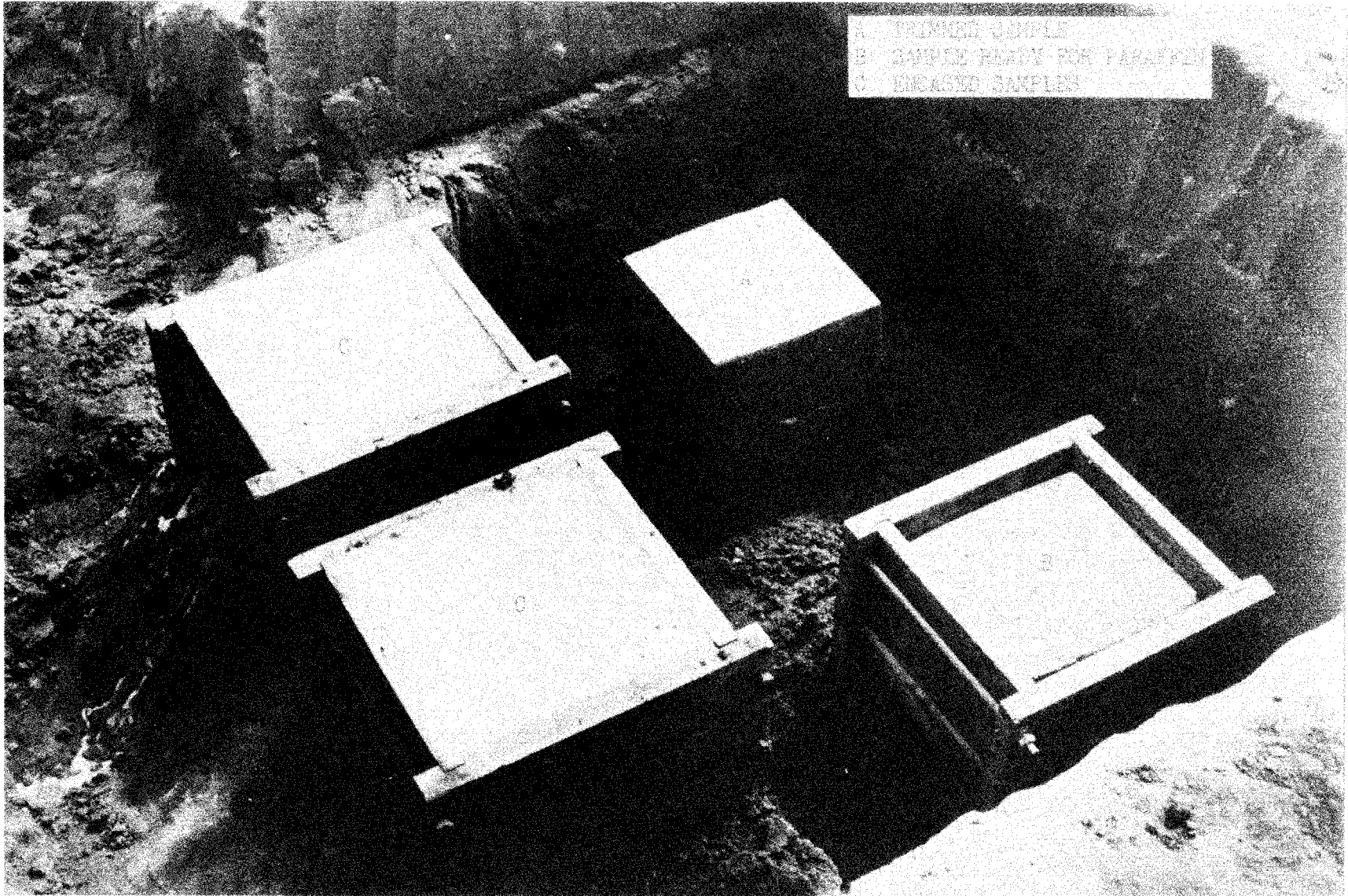

Figure 11-1. Photograph of the GEI sampler which incorporates the advanced trimming technique for obtaining a soil sample



F-11-11

Figure 11-2. Photograph of block samples in various stages of trimming and sampling

EM 1110-1-1804
1 Jan 01

Chapter F-12

Sampling from Stockpiles and Bins, Transportation Units, or Conveyor Belts

12-1. Introduction

Sampling from stockpiles, storage bins, loaded freight cars or trucks, and conveyor belts is unique. Because segregation of the material may occur within the unit, especially for well-graded aggregates, samples should be obtained only if proper sampling techniques and intervals or locations are considered and employed. The principal objectives which must be considered include obtaining samples that are representative of the mass of material, or obtaining samples to document the variability within the mass, or both. The volume or mass of a representative sample should be large enough not to be affected by the variability of small units of the bulk material; by contrast, the volume of a random sample should be small enough such that significant variability within the unit is not masked. With other factors constant, larger samples will tend to be more representative of the total. In most cases, sample disturbance is unimportant.

If significant variability of one or more specific parameters for the respective sampled units is found to exist, regardless of whether samples were obtained for assessment of variability or uniformity of bulk material, a statistical study should be considered as a means for interpreting the test results. A suggested method is described in ASTM E 122-89: “Standard Recommended Practice for Choice of Sample Size to Estimate a Measure of Quality for a Lot or Process” (ASTM 1992c). According to ASTM E 122-89, two approaches can be used: (a) determine the number of samples required to meet a prescribed precision, or (b) determine the precision which can be estimated based upon the number of available samples. Based upon this ASTM specification, an estimate of an average characteristic or parameter of the bulk material may be made.

Because of the difficulty of devising a comprehensive sampling plan to obtain a few representative samples to assess the characteristics of bulk material, a general sampling plan does not exist. Each sampling plan must be devised to satisfy the requirements of the specific study. The suggestions which are presented in paragraph 12-2 regarding a sampling plan are intended for guidance only. It is hoped that these suggestions will stimulate ideas for developing better and more comprehensive plans for sampling specific units of material. Geotechnical personnel are encouraged to use imagination, common sense, technical knowledge, and experience to develop a plan for sampling the material which will permit the acquisition of data of a quality necessary to satisfy the specific engineering requirements.

Additional reading materials which are suggested as guidance for developing a plan for obtaining representative samples of materials from stockpiles, bins, transportation units, or conveyor belts include ASTM C 50-86 (ASTM 1992b), C 702-87 (ASTM 1992a), D 75-87 (ASTM 1992a, 1992b, 1993), D 3665-82 (ASTM 1992b), E 105-58 (ASTM, 1992c), E 122-89 (ASTM 1992a), and Roberts et al. (1991).

12-2. Sampling Plan

When the contents of stockpiles, storage bins, loaded freight cars or trucks, or conveyor belts are sampled, the laws of chance dictate that a few particles may be unequally distributed among samples which are smaller than the whole unit. However, a properly designed sampling plan will tend to minimize the effects caused by sampling errors. Samples should be taken at random with respect to

location, time, or both, to minimize any bias on behalf of the person obtaining the samples. Samples may be examined individually to assess the variability of the material or combined to form a representative sample. If power equipment is available, the bulk material should be sampled from its top to its bottom. If power equipment is unavailable, samples should be obtained at several locations or increments of time. Because certain materials tend to segregate as a result of handling, care is necessary to ensure that samples do not contain a disproportionate share of material from the top or bottom layers of the unit. ASTM D 3665-82: "Standard Practice for Random Sampling of Construction Materials" (ASTM 1992b) provides additional guidance.

To satisfy the requirements for obtaining samples at random which, by definition, is the product of a definite and willful effort to produce disorder, several criteria should be considered. All units, i.e., a stockpile, storage bin, freight car or truck, or material on a conveyor belt, should be defined by some rule or number to ensure that randomness is satisfied. Every portion of a unit must have a nonzero chance of selection with respect to location, time, or both. The probability of selection of a given unit, area, or zone of material must be known. Each sample of material must be weighted in inverse proportion to its probability of selection.

Before a good sampling plan can be developed, the problem and objectives of the sampling operation should be identified. Information about relevant properties, i.e., gradation of the material, percent passing the U.S. Standard Sieve No. 200 (0.074 mm) sieve, water content of the coarser as compared to the finer fraction of the material, etc., should be collected. A number of potential plans for sampling the material should be evaluated. Costs, difficulties of obtaining samples, types and availability of sampling equipment, and the required number of samples or the desired precision of data, and the representativeness or randomness of samples should be considered. The potential plans should be evaluated, and the most desirable plan should be selected. Upon the commencement of the sampling operations and again as the preliminary data are evaluated, the preceding steps should again be reconsidered. Suggested sampling plans for obtaining representative samples based upon location and/or time increments for specific engineering purposes follow.

a. Loaded freight cars or trucks. For loaded freight cars or trucks, determine the number of samples required and estimate the number of freight cars or trucks which will be used to transport the material. Establish suitable criteria for sampling the material at all locations within the respective transportation units. Use random numbers to determine which transportation units will be sampled and the location within the respective units in which samples will be obtained. For example, a truck which is loaded with bulk material may be arbitrarily divided into four equal quadrants, as determined by a plan view of the truck box. Based upon the proposed sampling plan, use random numbers to determine which truck(s) will be sampled; repeat the process to determine which quadrant of material in a specific truck will be sampled. If power equipment is available, a cross section of material should be obtained for the full depth of the material. If power equipment is not available, obtain samples from a horizontal cross section of material at a reasonable depth below the surface of the material. Within practical limitations, sampling of bulk materials should be done in a manner which will prevent disproportionate shares of the top or bottom layers of material from being obtained. When packaged materials are to be sampled, assume that a stack of bags or containers is analogous to a quadrant of the truck box and that depth corresponds to a particular container within a specified stack of containers.

b. Conveyor belts. For conveyor belts, determine the number of samples required and estimate the length of time needed to transport the material on the conveyor belt. By the use of random numbers, determine the elapsed time when samples are to be obtained. All materials within the cross section of the conveyor belt, including fines, should be carefully sampled. A similar procedure can be used for

sampling a windrow of material; the principal difference is that the time variable for the conveyor belt should be replaced by the length of the windrow.

c. Storage bins. Two options are available for sampling the contents of storage bins. The material may be sampled as it is removed from storage bins through chutes, hoppers, or conveyor belts. The other option consists of sampling within the confines of the storage bin; samples should be obtained at various locations and depths within the material. To obtain samples from a conveyor belt or chute, follow the procedures for random sampling with respect to time that are given in paragraph 12-2*b*. If samples are obtained from within the storage bin, follow the guidance for sampling loaded freight cars and trucks. If power equipment is available, samples should be obtained from random depths and locations; the sampling plan should ensure that a disproportionate volume (mass) of the top or bottom layers of material is not obtained. If power equipment is unavailable, obtain samples from a horizontal cross section of material at a reasonable depth below the surface of the material.

d. Stockpiles. To obtain samples of the material in a stockpile, the use of power drilling and sampling equipment is more desirable than obtaining samples by hand. Establish a plan for sampling the contents of the stockpile at various locations and depths similar to the procedures which were given in the example for sampling transportation units. By the use of random numbers, select zones of material to be sampled. If power equipment is unavailable, develop a plan for sampling the material at random locations along the periphery of the pile. For example, zones of material located at elevations of 1/3 and 2/3 or 1/4, 1/2, and 3/4 of the height of the pile as well as the top of the pile should be sampled. As a general rule, do not sample the bottom 1/4 of the stockpile because disproportionate amounts of coarser material may have fallen to the base of the stockpile. Test results should be interpreted cautiously; it is possible that materials in stockpiles may have segregated.

e. Roadways. To obtain record samples for quality control of subbase or base materials for roadways, determine the length of the foundation material and the number of samples required, similar to the procedures which were suggested for obtaining samples of materials in windrows or on conveyor belts. The location with respect to the center line of the roadway can be treated as analogous to the depth of material in a transportation unit or stockpile. Select a random number to determine the station along the center line of the roadway; repeat the process to determine the location perpendicular to the center line of the roadway for obtaining the sample.

12-3. Sampling Procedures

In general, it is more desirable to use power drilling and sampling equipment than small hand tools to obtain samples of bulk material because a fairly large volume (mass), i.e., 0.01 to 0.1 m³ (1/3 to 4 ft³) or more, of material for each sample is often required. Furthermore, the use of power equipment permits samples to be obtained at relatively great depths. Equipment, such as hollow- or solid-stem augers, drive samplers fitted with basket retainers, or various types of vibrator samplers affixed to a crane or cherry picker, has been used to sample bulk materials. These types of drilling and sampling equipment have been described in Chapters 3, 5, 6, 7, and 8 and therefore will not be discussed here.

However, if drilling and sampling equipment is not available or cannot be used because of specific constraints, such as cost-ineffectiveness or inability to access storage bins or stockpiles with the power equipment, samples can be obtained by hand excavation. The remainder of this chapter presents guidance for obtaining representative samples of bulk material by hand-sampling techniques.

Methods and techniques for obtaining samples of geotechnical materials which are stored in stockpiles or storage bins or loaded on freight cars or trucks are suggested in the following paragraphs. Samples may be taken from loaded freight cars or trucks; from conveyor belts delivering materials to or from stockpiles, bins, or transportation units; from storage bins at the point of discharge or from an exposed surface; from exposed surfaces of stockpiles; or from packaged materials.

a. Loaded freight cars or trucks. To obtain samples of material from a transportation unit, select the zone of material to be sampled, as determined from the sampling plan which was discussed in the preceding paragraphs. Excavate two trapezoidal-shaped trenches across the segment of the transportation unit to be sampled; the trenches should intersect to form a “cross” at the center of the quadrant, as determined by a plan view of the transportation unit. The bottom of the trenches should be level and at least 0.3 m (1 ft) deep and 0.3 m (1 ft) wide. At five locations along the bottom of these two trenches, obtain a sample by pushing a shovel downward into the material. As an alternative sampling plan, excavate three or more trenches across the unit that will give a reasonable estimate of the characteristics of the load. At least two shovelfuls of material should be obtained at random locations from the bottom of each trench. Each shovelful of material may be placed in a separate container or combined, depending upon the requirements of the investigation. The number of increments or the size of each sample can be adjusted accordingly to meet the requirements of the investigation. When bulk materials are sampled, sound judgment is required to ensure that disproportionate shares of segregated materials are not obtained.

b. Conveyor belts. Three locations can be used to sample the contents of a conveyor belt: the point of discharge of material onto the conveyor belt, an intermediate location on the conveyor belt, or the point of discharge of material from the conveyor belt. To sample at the point of loading or discharge, a stream of material can be captured. Care is required to ensure that the sampling device intercepts the entire width of the discharge stream and that material does not overflow the sampling device; these precautions are necessary to reduce the potential for segregation of material which could result in misinterpretation of the test data. If an intermediate point along the conveyor belt is sampled, the full width of flow must be sampled. Insert two templates, shaped as the cross section of the conveyor belt, into the material to define a volume (mass) of material to be sampled. Scoop all material, including fines, into a suitable container. Samples should not be obtained from the initial or final discharge from a storage facility or transportation unit; this material may be segregated.

c. Storage bins. Two methods are available for sampling the contents of storage bins: samples may be obtained at the point of discharge from the storage facility or from an accessible location, such as the top of the material stored in the facility. If samples of material are obtained at the point of discharge, follow the procedures which are described in the paragraph for sampling the contents of a conveyor belt. If samples are obtained from an exposed surface of material, such as the top of material in a storage bin, follow the procedures which are described in the paragraph on sampling the contents of transportation units. The number of increments which are sampled should be adjusted to the size of the storage bin and/or to satisfy the requirements of the investigation. Individual samples can be examined to determine the variation of material within the bin or combined for a representative sample. Use judgment to ensure that disproportionate shares of segregated materials are not obtained.

d. Stockpiles. To sample the contents of a stockpile, select a zone along the periphery of the stockpile at some point away from the bottom of the pile. Climb to a location about 1 m (3 ft) above the zone to be sampled. Shove a form or several boards vertically into the stockpile just above the zone to help prevent material from raveling down the side of the stockpile onto the material to be sampled. After the form has been placed, remove material from the surface of the stockpile to a depth of about 0.3 to

0.6 m (1 to 2 ft) perpendicular to the original surface of the stockpile. Obtain a sample by pushing a shovel into the material in a direction which is perpendicular to the original surface of the stockpile. Repeat this process to obtain the required number of samples or the desired volume (mass) of material. For fine aggregates, it may be possible to push or drive small-diameter sampling tubes into the material to obtain samples. If sampling tubes are used, remove the outer layer of material as previously described; then push the sampling tube into the material in a direction perpendicular to the original surface of the stockpile. Samples should be taken at various levels and locations on the stockpile; individual samples may be combined for a representative sample or placed in separate containers to evaluate the variability of material in the stockpile. As a general rule, do not sample the bottom or exposed surfaces of the stockpile because the coarser and finer particles may have segregated to a greater degree at these locations.

A power-driven front-end loader may be used to obtain sample(s) provided that care is taken to ensure that the sample(s) is representative of the contents of the stockpile. If a front-end loader is used, a sampling plan should be devised which satisfies all of the requirements which have been identified for hand-sampling methods; the principal difference is merely the volume (mass) of soil obtained by the front-end loader as compared to hand-sampling methods. According to the data presented in Table 12-1, a volume of material as large as 0.1 m³ (4 ft³) could be required, depending upon the gradation of material; this volume of material is negligible when compared to the volume of material which can be moved in the bucket of a power front-end loader. Hence, the use of the front-end loader for obtaining representative samples of materials from a stockpile may not be as feasible as hand-sampling techniques.

e. Roadways. For quality control of subbase or base materials for roadways, use hand-sampling techniques which are described in this chapter or in Chapter 11. If power drilling equipment is used, follow the methods and procedures which are described in Chapters 5 through 8.

f. Quarries and borrow pits. To obtain samples of aggregates from quarries or bank-run sands or gravels, follow the procedures which are discussed in the Chapters 5 through 8 if power-drilling and sampling equipment is used or Chapter 11 if samples are obtained by hand-excavation methods, depending upon the requirements of the investigation. Drill test holes or excavate to determine the lateral and vertical extent of the deposit and its quality. The required depth of the samples will depend on the quantity and character of the material that is needed, the nature and topography of the deposit, and the value of the material. If a visual examination of the material reveals that a significant variation of materials within the formation exists, a specific plan for sampling the materials, i.e., random locations to define the uniformity or variability of material or specific locations to define an anomaly, should be considered.

12-4. Required Volume of Samples

The volume (mass) of each sample of material must be tailored to satisfy the requirements for the investigation. The data in Table 12-1 can be used by geotechnical personnel to estimate the weight of material which is required to conduct a routine sieve analysis. If other tests are planned, the weight of material should be adjusted accordingly.

12-5. Preservation of Samples and Test Records

a. Preservation of samples. Samples should be placed in a noncorrosive container or bag and preserved as a representative sample for the particular zone or stratum of material. If the natural water content of the sample is to be preserved, the container must be waterproofed. For shipment, each sample of material should be packaged to prevent damage, such as loss or mixing of materials, freezing of aggregates, or change of water content, which could affect test results. Details for preserving and transporting soil samples are presented in Chapter 13; additional guidance is offered in ASTM D 4220-83 (ASTM 1993).

b. Test records. All pertinent data, including the project name, job or contract number, and the location of the respective samples, must be recorded on data sheets. The location of a sample should be referenced to a permanent control, whenever possible. A detailed description of the method(s) used to obtain each sample should be recorded. Each soil sample should be numbered and identified by visual techniques which are described in Appendix E; the sample number and a visual description of the material should be written on the data sheet as well as on a tag attached to the sample container. The type of sample container should also be noted. If field tests are performed, a data sheet for the various tests must be prepared giving all pertinent data which were determined. All data sheets should be dated and signed by the crew chief or technician performing the operation. Other details pertaining to test records are presented in Chapter 13.

12-6. Precautions

Caution should be exercised by personnel involved in sampling of material in stockpiles, storage bins, transportation units, or on conveyor belts. In addition to the normal precautions required for working in the proximity of power equipment, the use of dust-control masks may be needed when sampling bulk materials. Personnel are also advised to use caution when sampling the contents of storage bins or stockpiles; these materials may slough without warning. Supervisory and/or safety personnel should inspect and approve all techniques and procedures which are used to gain access to a particular zone of material within a stockpile or storage bin.

Table 12-1
Minimum Field Sampling Masses (after ASTM D 75-87)

| Nominal Size of Aggregate | Minimum Mass of Sample, kg |
|---------------------------|----------------------------|
| Fine Aggregate | |
| No. 8 (2.36 mm) | 10 (25 lb) |
| No. 4 (4.75 mm) | 10 (25 lb) |
| Coarse Aggregate | |
| 9.5 mm (3/8 in.) | 10 (25 lb) |
| 12.5 mm (1/2 in.) | 15 (35 lb) |
| 19.0 mm (3/4 in.) | 25 (55 lb) |
| 25.0 mm (1 in.) | 50 (110 lb) |
| 37.5 mm (1-1/2 in.) | 75 (165 lb) |
| 50 mm (2 in.) | 100 (220 lb) |
| 63 mm (2-1/2 in.) | 125 (275 lb) |
| 75 mm (3 in.) | 150 (330 lb) |
| 90 mm (3-1/2 in.) | 175 (385 lb) |

Chapter F-13 Handling and Storage of Samples and Sampling Records

13-1. Introduction

Frequently, the driller and the inspector are the only people who witness the drilling operations and the material brought to the surface. Both must work closely together to identify, preserve, and record any changes of material and conditions. These records, which include both the preserved soil samples and the written field logs, provide fundamental facts on which all subsequent conclusions are based, such as the need for additional exploration or testing, feasibility of the site, cost and method of construction, and evaluation of structure performance. In addition, these records may also be needed to delineate accurately a change of conditions with the passage of time, to form a part of contract documents, or to serve as a basis for evidence in a court of law.

The inspector is usually assigned the tasks of identifying and labeling the samples, preparing the samples for transport and storage, and maintaining a written record of the materials and conditions encountered. Although the inspector's tasks must necessarily be tailored to the specific investigation, this chapter provides general guidance which can be used by the inspector to ensure that samples are preserved and that a factual, clear, and complete set of records are obtained. It should be noted that for specific sampling operations, such as undisturbed or disturbed sampling operations on land or nearshore, additional information for handling and storage of samples and sampling records has been reported in Chapters 6, 8, 10, 11 and 12.

13-2. Handling and Storage

For the purposes of handling and storage, it is suggested in ASTM D 4220-83 (ASTM 1993) that soil samples can be divided arbitrarily into four groups. Group A samples are obtained for visual classification purposes only. Group B samples are obtained for water content and classification tests. Bulk samples which are obtained for engineering properties tests, such as strength, deformation, and permeability tests, on remolded or reconstituted specimens are also classified as Group B samples. Group C samples include intact, naturally formed, or field-compacted samples which are frequently described as "undisturbed." Engineering properties tests, similar to those described for Group B soils, can be conducted on these samples. Group D samples are similar to the Group C samples except they are very fragile or highly sensitive. Laboratory tests, similar to the tests for Group C samples, can be conducted on these samples.

Depending upon the type of sampling device and the intended purpose of the samples, similar procedures are required for handling and storage of all groups of samples; the principal difference is the degree of disturbance which is permitted. Because the emphasis of many sampling operations is directed towards obtaining high-quality undisturbed samples, i.e., Group C or Group D samples, the guidance which is presented in this chapter is primarily directed towards undisturbed sampling operations. However, this information is also applicable for Group A or Group B samples, i.e., disturbed samples; the requirements for preventing disturbance to the samples, such as shock or vibration, are simply relaxed.

a. Removal of sample from sampling device. After the sampling device has been withdrawn from the borehole, the sampling tube should be disconnected from the sampler without shocks or blows. The gross length of the sample, which is a good indicator of sample condition, should be determined to the

nearest 3 mm (0.01 ft). If the sample is stored in the sampling tube, a small representative sample from the bottom of the sample should be trimmed and placed in a glass jar and sealed. The net length of sample should be determined to the nearest 3 mm (0.01 ft), and the portion of tube to be sealed should be thoroughly cleaned before the sample is sealed. For open-tube samplers, sludge which has accumulated on top of the sample should be removed before the length of the sample is determined. For piston samplers, any space between the piston and sample, or any movement of the piston or piston rod as the clamp is released should be noted. If water or drilling mud is located between the piston and the sample, note the distance between the piston and sample and the volume of water, if possible.

For samples which are extruded from the sampling tube, the sludge and drilling mud should be cleaned from the sampling tube, and the gross length of the sample should be determined before the sample is extruded. After the undisturbed sample has been extruded, the gross length of the sample should again be measured, a small representative sample should be trimmed from the bottom of the sample and placed in a glass jar and sealed, and the net length of the sample should be determined. To minimize or prevent additional disturbance as the sample is extruded from the sampling tube, the barrel should be held horizontally and the sample should be extruded directly onto a half-section tray in the direction that it entered the barrel. A hydraulic-pressure extruder is preferable to a mechanical extruder; a pneumatic-pressure-extruder should not be used. The advantages of extruding the sample from the tube include reusing the sampling tube, avoiding increased adhesion of the sample to the tube with time, minimizing the potential for corrosion of the metal sampling tube and chemical change on the periphery of the sample as a result of contact with the metal tube, minimizing the potential for migration of pore water by separating the sample by material type and by removal of seriously disturbed portions of the sample, and recording more detailed descriptions of soil type and stratigraphy. The disadvantages include the increased potential of sample disturbance as a result of additional handling and drying of the sample. The costs due to extruding and sealing the samples in other containers could be somewhat higher than costs for sealing the samples in the sampling tubes.

b. Identification of soil. One of the responsibilities of the inspector is to identify the soil type and to note when changes of soil or stratigraphy occur. A record of all major changes in the character of the soil, including its classification, color, water content, consistency, etc., must be made. Descriptions of the soil should be based upon the visual examination of samples taken from each stratum and should be consistent with the procedures in Appendix E. For example, a sample may be described as a dense, tan, wet, uniformly-graded, subrounded, medium sand with occasional clay lenses. Most importantly, be consistent with the visual descriptions, even if they do not agree with the soils classifications determined in the laboratory.

If the sample is extruded, the stratigraphy can be based upon a visual examination of the core and the classification of a representative sample; if the sample is not extruded, the stratigraphy of the sample must be based upon a description of the soil at the top and bottom of the tube. Changes that occur in zones not sampled can usually be determined by a conscientious, capable geotechnical driller by the action of the drill rig and bit and changes in the drilling fluid return. When changes are detected, the penetration of the bit should be stopped, the depth should be determined to the nearest 30 mm (0.1 ft), and a sample should be taken. This step ensures that a sample of each stratum is obtained before additional changes are encountered.

c. Labeling samples. As samples are removed from the respective borings, they should be numbered by boring and consecutive order, such as 1, 2, and 3, and by the depth of the respective samples. The depth to the top and the bottom of the sample should be recorded to the nearest 30 mm (0.1 ft). Sectioned liners or jar samples should be identified as a subsample, such as 1a, 1b, 1c, 2a, 2b,

and 2c. Care should be exercised to ensure that the correct orientation i.e., top and bottom, of all samples is maintained and that samples are marked accordingly. Sectioned liners should be marked to permit orientation of segments for examination of stratification or for determination of the strike and dip.

Samples should be identified with tags, labels, or other suitable markings, such as writing on the sample tube with paint or permanent marker or etching the sample tube. Label tags should be marked with nonfading, permanent ink and protected with a coating of wax. For disturbed samples such as bulk samples, a waterproof identification tag should be placed inside the container before it is sealed; the sample identification data should also be marked on the outside of the container. For jar samples, labels should be glued to the outside of the container (not the lid). Waterproof, duplicate tags should always be placed inside the sample container. An example of two types of tags (ENG Forms 1742 and 1743) for labeling and identifying soil samples are presented in Figure 13-1.

Regardless of the quality or quantity of samples, samples are worthless if inadequate or conflicting identification and labeling of samples occur. The inspector must ensure that each sample is labeled consistently with the data in the boring logs. Samples should be identified with the following information:

- Project name or number and location.
- Sampling date.
- Boring number, sample number, depth/elevation.
- Soils description.
- Gross and net lengths, sample orientation, and method of sampling.
- Special instructions, problems, observations, or general remarks.

d. Preservation of samples. To ensure the success of the laboratory testing program, preservation of the inherent conditions of the soil samples is critical. In general, the first step towards preserving the sample is to seal it in a sturdy container. Depending upon the proposed use of the soil sample, as indicated by Groups A through D, suitable containers as well as the method for sealing, shipping, and storing the containers should be selected which will prevent the loss of soil moisture, prevent differential movement between the container and the sample, and minimize the potential for chemical change, as indicated by the presence of rust, mold, or fungus on the periphery of the sample. Several methods are suggested in the following paragraphs. Ultimately, however, the procedures or requirements for preserving and/or sealing the soil samples should be defined by a designated responsible person or included in the project specifications.

Group A samples, which are obtained for visual classification purposes, can be preserved and transported in any type of container that meets minimum requirements to prevent sample loss during transport and storage. Small representative samples can be placed in glass or plastic jars; bulk samples can be stored in heavy-duty plastic bags or in tightly woven, mildew-resistant cloth, canvas, or burlap bags.

Group B samples, which are disturbed samples obtained for water content, classification, or engineering tests on reconstituted specimens, must be preserved and transported in sealed, moisture-proof containers. Containers must be of sufficient strength to assure against breakage and meet the minimum requirements

of the transporting agency. Suitable containers include plastic bags, glass or plastic jars or buckets, or carton containers. Buckets, jars, and other carton containers should be sealed with lids with rubber-ringed seals, tape, microcrystalline waxes, etc., or combinations thereof; thin-walled sample tubes or liners should be sealed with expandable packers, caps, tape, waxes, etc.; and bulk samples should be sealed in heavy-duty plastic bags or wrapped with alternating layers of cheesecloth and wax.

Group C and Group D samples, which are commonly referred to as undisturbed samples, must be protected from changes of water content, shock, vibration, temperature extremes, and chemical changes. Undisturbed samples can be preserved in sample tubes or liners or can be extruded, coated with wax and/or cheesecloth and wax, and sealed in sturdy containers, such as wooden boxes, carton containers, or glass or plastic jars or buckets. Before the undisturbed sample is sealed in its container, a small representative sample of soil should be removed from the bottom of the sample, placed in a wide mouth jar, and sealed with rubber-ringed lids or lids with a coated paper seal. The soil in the jar sample can be used for preliminary examination and laboratory classification tests without breaking the seal of the undisturbed sample.

If the sample is preserved in the sampling tube or liner, the ends of the tube can be sealed using several different techniques. One of the most common methods consists of mechanically expanding an O-ring which has been placed between metal or plastic disks against the inside wall of the sampling tube. Plastic, rubber, or metal caps can be placed over the end of the thin-walled tube or liner and sealed with waterproof plastic tape, friction tape, duct tape, or wax. Another method consists of placing 25-mm- (1-in.-) thick prewaxed wooden disks or 2-mm- (1/16-in.-) thick metal or plastic disks inside the sampling tube or liner and sealing with wax or caps and tape, or both.

If the sample is extruded from the sampling tube, samples are commonly coated with wax or cheesecloth and wax and placed in sturdy containers. Smaller samples should be painted with several light coats of wax to minimize penetration of the wax into the voids of the specimen and then dipped into liquid wax to obtain a layer of wax approximately 3 mm (0.1 in.) thick. If a thicker/stronger wax coating is needed to protect the sample, cheesecloth can be wrapped around the sample before it is dipped into the liquid wax. For larger or more porous or coarse-grained samples, cheesecloth should be placed on the sample before it is painted with wax; this procedure will help to prevent wax from migrating into the voids of the sample. After the sample has been placed in a sturdy container, the annulus between the sample and the container should be filled with wax or foam packing material for additional protection for the sample.

An alternative procedure for preserving extruded samples is to place the sample in a carton container and fill the annulus between the sample and the container with wax. If this procedure is used, the wax coating may not be as tight as for dipped samples. Furthermore, care is necessary to ensure that voids do not exist between the sample and its container after the sample has been sealed. If the annulus is not filled, the sample is improperly sealed; disturbance could result from a change of water content or structural damage to the sample, a chemical change or growth of mold or fungus on the periphery of the sample, or corrosion and deterioration of the sample container.

Large, undisturbed block samples should initially be covered with cheesecloth and then painted with one or two light coats of wax and then covered with at least two additional alternating layers of cheesecloth and wax. After the sample has been placed in a suitable container, such as a wooden box, the annulus should be filled with wax or other suitable packing material. The top of the box should be attached to the container with screws or hinges and latches; driving nails to attach the top to the box disturbs the sample because of shock and vibrations.

A variety of waxes are available for sealing tubes and containers. The most commonly used waxes include microcrystalline wax, paraffin, beeswax, ceresine, carnaubawax, or combinations thereof. For most applications, a combination of waxes, such as a 1 to 1 mixture of microcrystalline wax and paraffin, should be used for sealing soil samples. To obtain a seal, the temperature of the wax should be limited to about 10 deg C (18 deg F) above its melting point. If its temperature is too high, the wax will tend to penetrate the pore spaces and cracks of the soil, whereas if its temperature is too low, the wax will congeal before it has filled the annulus between the sample and the container. Qualitatively, an object, such as a pencil, which is inserted in wax at the proper temperature for coating samples will be coated with congealed wax immediately upon its withdrawal; the coating will not bond to the object. However, if the wax is too hot, it will appear clear and bond to the object.

Although wax is commonly used for sealing soil samples, limitations of its use should be recognized. First, the loss of moisture from undisturbed samples is undesirable because the engineering properties and, for certain soils, the classification test results change as a result of a change of water content. Unfortunately, wax seals are not impermeable, and soil samples will therefore tend to lose moisture during prolonged storage. It is sometimes desirable to weigh samples before and after sealing and before the tube is opened for laboratory testing. When the sample tubes are opened, the difference of weights between the measurements obtained in the field and after storage, if any, should be reported to designated responsible laboratory personnel. Other characteristics of waxes include shrinkage as a result of cooling, increased brittleness in cooler weather, and softening and plastic deformation due to the weight of the soil sample in warmer weather. Consequently, the wax seals should be inspected at regular intervals during storage and deficiencies should be corrected.

Corrosion is dependent upon the type of metal in the tube, the salts in the pore fluid, and perhaps the soil constituents. It is increased by the presence of air. The most obvious effects of corrosion include roughness of the walls of the sample tube and adhesion of soil to the sample tube which would increase the difficulty of extruding the sample and cause additional disturbance to the sample. The less obvious effect is the potential change of the chemistry of the pore fluid and the influence of this change on the engineering behavior of test specimens. To minimize the potential for chemical change, as inferred by the presence of corrosion on the sample tube and caps, the tube and the caps for sealing the tube should be made of plastic or noncorrosive metal or coated with a hard, smooth lacquer. The tubes and caps should be of the same metal or electrically inactive metals to avoid electrolysis. If plastic tubes or caps are used, a plastic material should be used which does not contain constituents, such as heavy metals, that could adversely affect the results of a chemical analysis of the soil sample.

e. Transporting samples. Transporting samples to the laboratory may involve transit by a commercial carrier or by a Government-owned vehicle. As a minimum, the samples should be packed in containers which satisfy the requirements of the transporting agency, protect the samples from disturbance due to shock, vibration, or temperature extremes, and prevent loss of samples due to damage or destruction of the container. The transportation of samples is also subject to regulations established by the U.S. Department of Agriculture, Animal and Plant Health Service, Plant Protection and Quarantine Programs, and other federal, state, or local agencies. The length, girth, and weight of the containers for packing and shipping the samples should be considered and preplanned to ensure that the necessary boxes and packaging materials are available. The top of the shipping crate (top of the samples) should be marked "THIS END UP." Special instructions, descriptions, and labels for containers may also be required when radioactive, chemical, toxic, or other contaminated material is transported; the procedures or requirements should be included in the project specifications or defined by a designated responsible person.

Group A and Group B samples can be transported in almost any type of container and by any available mode of transportation. Samples may be transported without special protection, although it is desirable to pack the samples in shipping containers, such as cardboard or wooden boxes or crates, to meet the minimum requirements of the transporting agency, for ease of handling, and to prevent the loss of sample tags or material.

Group C and Group D samples should be transported under the supervision of personnel from the sampling/testing agency whenever possible. As a minimum requirement, samples should be transported in wood, metal, or other type of reusable container that provides cushioning and insulation for each sample. Samples should fit snugly in each container to prevent rolling, bumping, etc., and should be protected against vibration, shock, and temperature extremes. Sawdust, wood shavings, rubber, polystyrene, urethane foam, plastic bubble wrap, or materials of similar resiliency can be used as cushioning material. The cushioning material should completely encase the sample. Special conditions, such as freezing, controlled drainage, and confinement, should be provided as needed. In addition to the preceding requirements, all modes of transportation, including loading, transporting, and unloading, for Group D samples should be supervised by a qualified person.

Undisturbed samples of cohesive soils must be effectively protected from excessive heat, cold, vibration, and/or shock during shipment, since these phenomena may cause serious sample disturbance. Cohesive samples should be shipped upright with 8 to 15 cm (3 to 6 in.) of cushioning material placed between samples and the bottom and sides of the container or transporting vehicle, and at least 5 cm (2 in.) over the top and between individual samples. This method of packing provides protection from heat in summer and from freezing in winter; however, if samples are in transit more than one day in freezing weather, the vehicle should be stored overnight in a heated building. Samples transported by commercial carriers should be packed in boxes that can withstand considerable handling. Boxes made of 13- to 19-mm- (1/2- to 3/4-in.-) thick marine plywood normally are satisfactory. About 75 mm (3 in.) of cushioning material should be placed between the samples and the walls of the box. Examples of reusable containers are presented in ASTM D 4220-83 (ASTM 1993). Boxes should be marked for careful handling; special arrangements should be made with the transportation company to ensure proper handling.

Free-draining cohesionless samples may be frozen in the tube at the field site and kept in a frozen state until laboratory tests are conducted (see paragraph 6-5). However, samples must be thoroughly drained prior to freezing to prevent disruption of the structure by expansion of water upon freezing. The frozen samples may be transported from the field in insulated containers containing dry ice or in electrically-operated freezers powered by portable generators. Adequate cushioning material must completely surround each sample prior to shipment.

If samples of cohesionless soil were obtained for the principal purpose of density determinations, the sample tubes should be placed horizontally in a cushioned rack after adequate drainage has occurred. After the samples have been secured to prevent rotation, the "top" of each tube should be marked and then struck 50 light blows with a rubber hammer, starting at one end of the tube and working toward the other end and then back again. The blows of the hammer cause the sand to consolidate and thus prevent lateral movement and possible liquefaction of the material in the tube during transportation. Upon arrival at the laboratory, the sample tubes can be sawed into sections; the weight (mass) of soil in each section of tube and the volume of the tube can be used to calculate the density of the soil in the tube at the instant that the sample was recovered.

Before the samples of cohesionless soil obtained for density determination are transported to the laboratory, a thick pad of cushioning material should be placed between the truck bed and the bottom rack of samples. The longitudinal axis of the sample tube should be oriented perpendicular to the direction of travel to minimize soil displacement during acceleration or deceleration of the vehicle or differential elevation between the front and rear of the truck bed.

f. Storage. When samples are received at the laboratory, they should be inventoried, the sealing and marking of each sample should be checked, and the deficiencies should be corrected before they are placed in an upright position in a storage room. Although it is desirable to test samples as soon as possible to prevent further disturbance caused by chemical and physical changes, storage of samples is sometimes required before testing can be conducted and/or completed. If storage is required, samples should be stored in a moist, cool, frost-free environmental room maintained at 100 percent relative humidity. A temperature between 2 and 4 deg C (35 and 40 deg F) is recommended to preserve the samples, unless frozen, and to prevent the growth of mold and other organisms. Ultraviolet light can be used to retard the growth of fungus.

When samples are opened for laboratory testing, the seal should be checked and its condition noted. If the weight of the sample has been obtained in the field, the weight in the laboratory should be obtained for comparison. After the caps have been removed and the sample tube opened, the exposed sample should be checked for migration of water and examined for structural or chemical changes, such as discoloration, pitting, cracks, and hard and soft areas. The empty sample container should be inspected for corrosion and adhesion of soil as well. Observations should be noted and reported to the responsible laboratory personnel.

13-3. Written Record

Because the written record, hereinafter referred to as boring logs, provides fundamental facts on which all subsequent conclusions are based, the necessity of recording the maximum amount of accurate information cannot be overemphasized. Although there is no single procedure for recording the data, the record should reflect all details of the investigation. The location or position of each borehole, test pit, or trench should be clearly located horizontally and vertically with reference to an established coordinate system, datum, or permanent monument. The boring logs should contain information on the materials encountered, the number and type of samples obtained, the depth and length of the samples, the percentage of core recovery or recovery ratio, etc. The logs should also indicate the type of equipment used, such as a drilling bit or auger, whether or not casing was used, the type of drilling fluid, and the size of the borehole. Conditions to be recorded include the following: the properties of the drilling mud, such as weight, viscosity, and filtration characteristics; difficulties in drilling, such as squeezing or caving formations; the date, depth, and rate that any water was lost during drilling operations, including the addition of drilling mud or water; or the date and depth of seepage or water bearing zones and piezometric levels in each hole, boring, or pit; and the equilibrium depth of the water table after drilling was ceased. Maps or sketches with accurate descriptions and photographs are extremely helpful for documenting the record of the site investigation.

Because the field logs form the basis for determining the soil profile and contribute to an estimate of the quality of the samples and the in situ conditions, written records should be accurate, clear, concise, and account for the full depth of the boring. A standardized notebook system is recommended. Notes, including all observations, should be kept in an organized, orderly manner, and should be recorded on the spot and not from memory at a later time. In general, symbols and abbreviations should not be used because of the potential for confusion and misunderstanding. Furthermore, the use of symbols and

abbreviations increases the difficulty of reading and understanding the boring logs for those not familiar with the symbols and abbreviations. Figures 13-2 and 13-3 illustrate two forms of boring logs and typical information which must be recorded. An examination of the data which are presented in these figures reveals that undisturbed sampling operations were recorded on the form given as Figure 13-2, whereas disturbed sampling operations were recorded on the form given as Figure 13-3. It should be noted that these forms may be used interchangeably provided that accurate and concise records are maintained. The style of the form is superfluous as compared to its purpose.

A checklist of data which should be included in the field logs follows:

- The name or number of the project and its location.
- The names and positions of members of the field party.
- Borings and/or test pits or trenches should be located by coordinates and referenced by numbers, letters, or names in a detailed map. The ground surface elevation of each boring or test pit should be referenced to an established datum which cannot be affected by construction operations. Include the date(s) of the start and completion of each boring, test pit or trench, or field test.
- Describe the method(s) of advancing the borehole and the methods for stabilizing the borehole, such as the density, viscosity, and filtration characteristics of the drilling mud, or the location of the casing. The penetration resistance(s) and the method(s) used to force the sampler into the soil are useful for estimating the compactness or consistency of soil in situ. A change of strata can frequently be identified by the rate of penetration or the feel of the boring tools.
- Record all major changes of soil strata. Every stratum that is substantially different from the overlying and underlying strata should be located by depth interval, classified, and described in the log. The report should include a description of the soil in each stratum. All lenses, layers, pockets, planes of failure, or other irregularities should be located and described, although thin lenses, i.e., less than 5 mm (0.02 ft), of a relatively uniform stratum do not need to be separately classified on the log. At least one sample should be obtained from each stratum.
- Record the number of the sample and its depth, preferably to the top and to the bottom of the sample. Include information on the type and diameter of the sample, the inside clearance of the cutting edge, the depth of penetration to the nearest 30 mm (0.1 ft), and the gross and net lengths of the sample to the nearest 3 mm (0.01 ft). The depth of penetration should include the initial penetration caused by the weight of the drill rods; the length of the sample should include the downward movement required to engage the core catcher.
- The soil should be described according to the Unified Soil Classification System with definitive adjectives (see Appendix E). Include its natural color as well as the range of colors for moist to dry conditions, its consistency for wet to dry conditions, the grain size and sorting, the structure of the soil mass, the type and degree and type of cementation (if applicable), degree of weathering, etc.
- Note sources of potential disturbance, such as unsuccessful or difficult sampling operations, obstructions or unusual observations, caving or plastic movement of the soil in the borehole, poor sample recovery, and slaking of the soil samples.

- Note the groundwater conditions, including the depth to the phreatic surface or the depth at which loss or inflow of water occurs. If water loss or inflow occurs, measure the groundwater level, the rate of inflow, the method of control, the number of pumps and the capacity of each, etc.
- In some cases, a color photograph may be beneficial. Include a scale and a color card in the photograph, because the color card will permit a comparison of colors to be made at later date.

13-4. Precautions

Sampling, preserving, and transporting soil samples may involve contact with hazardous materials, equipment, and operations. This manual does not purport to address the safety problems associated with its use. It is the responsibility of the principals involved in the site investigation to establish appropriate safety and health practices and to determine the applicability of regulatory limitations. Special instructions must accompany any sample of contaminated material. Interstate transportation, storage, and disposal of soil samples may be subject to regulations established by the U.S. Department of Agriculture and other federal, state, or local agencies.

ER 1110-1-5 describes responsibilities and procedures for identification, shipping, storage, testing, and disposal of soil samples (whether disturbed or undisturbed) from areas quarantined by the U.S. Department of Agriculture, or from areas outside the continental limits of the United States. Soil samples taken below a depth of 1.5 m (5 ft) are generally not considered infected and are not subject to handling and treatment prescribed for regulated soil. Entry clearance is required for all soil samples imported from foreign countries and from Hawaii, Guam, Puerto Rico, the Virgin Islands, and the Canal Zone.

| | | | | |
|-------------------------------|------------|-------------------------------------------------------------------------------|-----------|------------------------------|
| FROM | PROJECT | | LOCATION | |
| | HOLE NO. | DEPTH: FROM— | | TO— |
| | | ELEVATION | | |
| | SAMPLE NO. | CLASSIFICATION | | |
| | | TYPE: <input type="checkbox"/> DISTURBED <input type="checkbox"/> UNDISTURBED | | |
| | REMARKS | | | |
| | DATE | | INSPECTOR | |
| ENG FORM 1 JAN 49 1742 | | <input type="checkbox"/> BAG | OF | <input type="checkbox"/> JAR |
| (EM 1110-2-1803) | | 19-8797-1 GPO | | |

| | | | | |
|------------------------------------------|------------|-------------------------------------------------------------------------------|-----------|--|
| FROM | PROJECT | | LOCATION | |
| | HOLE NO. | DEPTH | | |
| | | FROM | TO | |
| | ELEVATION | | | |
| | SAMPLE NO. | CLASSIFICATION | | |
| | | TYPE: <input type="checkbox"/> DISTURBED <input type="checkbox"/> UNDISTURBED | | |
| | DATE | | INSPECTOR | |
| <input type="checkbox"/> BAG | | OF | | |
| <input type="checkbox"/> JAR | | | | |
| REMARKS | | | | |
| ENG. FORM 1 JAN 49 1743 (EM 1110-2-2300) | | | | |

Figure 13-1. ENG Forms 1742 and 1743 for labeling and identifying soil samples

| DRILLING LOG | | DIVISION | INSTALLATION | | Hole No. <i>MR-1</i> | |
|------------------------------------------------------------------------------------------------------------------------------|-------|----------|----------------------------------------------------------------------|-----------------|--------------------------------------------------------------------------------------------|---------------------------------------------------------------------------------------------------------|
| 1. PROJECT
<i>Morville Revetment Slide</i> | | | USAE Waterways Exp. Sta. | | SHEET 2
OF 8 SHEETS | |
| 2. LOCATION (Coordinates or Station)
<i>Range 2, #00' Riverside of Base line</i> | | | 10. SIZE AND TYPE OF BIT <i>as shown in "g" below</i> | | | |
| 3. DRILLING AGENCY
<i>USAEWES</i> | | | 11. DATUM FOR ELEVATION SHOWN (T.B.M. or M.S.L.)
<i>M.S.L.</i> | | | |
| 4. HOLE NO. (As shown on drawing title and file number)
<i>MR-1</i> | | | 12. MANUFACTURER'S DESIGNATION OF DRILL
<i>Falling Model 1500</i> | | 13. TOTAL NO. OF OVERBURDEN SAMPLES TAKEN
DISTURBED: <i>2</i>
UNDISTURBED: <i>18</i> | |
| 5. NAME OF DRILLER
<i>Brown</i> | | | 14. TOTAL NUMBER CORE BOXES
<i>None</i> | | | |
| 6. DIRECTION OF HOLE
<input checked="" type="checkbox"/> VERTICAL <input type="checkbox"/> INCLINED _____ DEG. FROM VERT. | | | 15. ELEVATION GROUND WATER _____ | | | |
| 7. THICKNESS OF OVERBURDEN
<i>Not determined</i> | | | 16. DATE HOLE STARTED
<i>16 July 1949</i> | | COMPLETED
<i>20 July 1949</i> | |
| 8. DEPTH DRILLED INTO ROCK
<i>0.0'</i> | | | 17. ELEVATION TOP OF HOLE
<i>57.6 Feet, M.S.L.</i> | | | |
| 9. TOTAL DEPTH OF HOLE
<i>75.0'</i> | | | 18. TOTAL CORE RECOVERY FOR BORING _____ % | | | |
| | | | 19. SIGNATURE OF INSPECTOR
<i>Elliott</i> | | | |
| ELEVATION | DEPTH | LEGEND | CLASSIFICATION OF MATERIALS (Description) | % CORE RECOVERY | BOX OR SAMPLE NO. | REMARKS (Drilling time, water loss, depth of weathering, etc. if significant) |
| | 10 | | | | | |
| | 11 | | <i>Clay, Silty, Brown, Stiff, CL</i> | | | <i>(Boring advanced with baffled fishtail using aquagel and water.)
6" Fishtail bit</i> |
| | 12 | | | <i>12.0</i> | | |
| | 13 | | | <i>13.2</i> | <i>1A</i> | <i>5" Shelby tube*
(Drive, 2.50'; Sample, 2.50';
gap between Spile & Piston,
0.00')</i> |
| | 14 | | <i>Clay, Medium, Gray, CH</i> | <i>14.8</i> | <i>2A</i> | <i>5" Shelby tube* (*Sample
ejected and encased with
wax in cardboard tube)</i> |
| | 15 | | | <i>14.3</i> | | |
| | 16 | | | | | <i>6" Fishtail bit</i> |
| | 17 | | | <i>16.5</i> | | |
| | 18 | | | | <i>3</i> | <i>3" Shelby tube (Drive,
2.48; Spile, 2.42; gap,
0.06')
(Mud wt. 70.0 lb/Cu. ft.)</i> |
| | 19 | | | <i>19.0</i> | <i>(tube
no. 26)</i> | |
| | 20 | | <i>Sand, Fine, Gray, SP</i> | | | <i>3 1/2" Fishtail (Mud wt.,
71.0 lb/Cu. ft.)</i> |

Figure 13-2. ENG Form 1836 for maintaining a record of drilling and undisturbed sampling operations

BORING LOG

| FIELD DATA | | | | | | | | | | LABORATORY DATA | | | | | |
|------------------------------------|------------|--------------------------------------------------|----|--------------------------|----|----------------------------|------|-----------------------------------|----------------------------------------------------------|------------------------------------------|--------|------------|--|---------------------|--|
| Project <u>Meriville Reentrant</u> | | Location <u>Range 4, 200' Curved of SL</u> | | Inspector <u>Elliott</u> | | Operator <u>Brown</u> | | Surface Elev. <u>54.3 ft. MSL</u> | | Natural Ground Elev. <u>54.3 ft. MSL</u> | | Date _____ | | Classified by _____ | |
| Drill Rig <u>W-4048</u> | | Boring advanced with <u>5 1/2" Solidog auger</u> | | TYPE OF SAMPLER | | CLASSIFICATION AND REMARKS | | CLASSIFICATION | | SYMBOL | | NAT WC | | | |
| SAMPLE NUMBER | DATE TAKEN | STRATUM | | DRIVE | | SAMPLE | | REMARKS | CLASSIFICATION | SYMBOL | NAT WC | | | | |
| | | FROM | TO | FROM | TO | FROM | TO | | | | | | | | |
| 1 | 6/18 0.0 | | | | | 4.9 | 5.4 | 5 1/2" Auger | Clay: silty, stiff, tan CL | | | | | | |
| 2 | 8.4 | 8.4 | | | | 8.6 | 9.1 | 5 1/2" Auger | Clay: sandy, hard, gray CL
Clay: sandy, hard, gray CL | | | | | | |
| 3 | 16.7 | 16.7 | | | | 14.0 | 14.5 | 5 1/2" Auger | Clay: sandy, hard, gray CL | | | | | | |
| 4 | 16.7 | | | | | 16.9 | 17.3 | 5 1/2" Auger | Sand: med, gray SP
Sand: med, gray SP | | | | | | |
| 5 | 21.5 | 21.5 | | | | 21.8 | 22.3 | 5 1/2" Auger | Clay: stiff, blue CH
Clay: stiff, blue CH | | | | | | |
| 6 | 21.5 | | | | | 21.5 | 28.0 | 5 1/2" Auger | Clay: stiff, blue CH | | | | | | |

WES Form No. 819
April 1954

Sheet 1 of 3 Sheets

Figure 13-3. Engineering form for keeping a record of disturbed sampling operations

Chapter F-14 Backfilling Boreholes and Excavations

14-1. General Safety Precautions

All open boreholes, test pits or trenches, and accessible borings, including shafts or tunnels, must be covered or provided with suitable barricades, such as fences, covers, or warning lights, to protect pedestrians, livestock or wild animals, or vehicular traffic from accidents (EM 385-1-1). After the excavations have served their intended purposes, the sites should be restored to their original state as nearly as possible. Boreholes or excavations which are backfilled as a safety precaution may be filled with random soil. The quality of the backfill material should be sufficient to prevent hazards to persons or animals and should prevent water movement or collapse, particularly when drilling for deep excavations or tunnels. The soil should be tamped to minimize additional settlement which could result in an open hole at some later time. If surface casing has been set, the casing may be capped. If an uncased borehole must be reopened at a later time, a pole which is slightly smaller in diameter than the borehole may be inserted into the hole; a crosspiece which has been firmly attached to the upper end of the pole will be useful for removal of the pole from the hole as well as marking the location of the borehole and preventing the pole from falling into the hole.

14-2. Grouting

All boreholes located on the landside and riverside of levees, upstream and downstream of dams and embankments, and in or under proposed structures should be grouted to prevent water from passing from one stratum to another through the borehole and/or to prevent piping to the surface. The borings should be grouted by injection through a grout pipe inserted to the bottom of the hole which will displace the water or drilling mud and fill the hole with a continuous column of grout. The grout should contain bentonite or some similar swelling material to inhibit shrinkage and ensure a good seal. A grout mixture of about 4 to 7 percent bentonite and 93 to 96 percent portland cement is suitable for sealing boreholes. Sand may be added to the grout as filler if the proper mixing and pumping equipment are available.

14-3. Concrete

Concrete may be used for backfill if a shrinkage inhibitor is added. Concrete should be placed in the bottom of the borehole by the tremie method to prevent segregation of the mixture and to ensure that water or drilling mud are displaced and the hole is filled with a continuous column of concrete (CE-1201).

Appendix F-1 (of EM 1110-1-1906) References and Bibliography

A-1. Required Publications

ER 715-1-13

Procurement of Diamond Drill Bits and Reaming Shells

ER 1110-1-5

Plant Pest Quarantined Areas and Foreign Soil Samples

ER 1110-2-1807

Use of Air Drilling in Embankments and Their Foundations

EM 385-1-1

Safety and Health Requirements Manual

EM 1110-1-1802

Geophysical Exploration

EM 1110-1-1804

Geotechnical Investigations

EM 1110-1-1905

Bearing Capacity of Soils

EM 1110-2-1906

Laboratory Soils Testing

CE-1201

Guide Specification for Civil Works Construction, Subsurface Drilling, Sampling and Testing

CE-1205

Guide Specification for Civil Works Construction, Diamond Core Drilling Bits and Reaming Shells

A-2. Related Publications

Acker 1974

Acker, W. L., III. 1974. *Basic Procedures for Soil Sampling and Core Drilling*, Acker Drill Company, Inc., Scranton, PA.

American Petroleum Institute 1983

American Petroleum Institute. 1983. "API Spec 13A - Specification for Oil-Well Drilling Fluid Materials," Ninth Edition, Dallas TX.

EM 1110-1-1804
1 Jan 01

American Society for Testing and Materials 1992a

American Society for Testing and Materials. 1992a. 1992 *Annual Book of ASTM Standards, Volume 04.02, Concrete and Aggregates*, Philadelphia, PA.

American Society for Testing and Materials 1992b

American Society for Testing and Materials. 1992b. 1992 *Annual Book of ASTM Standards, Volume 04.03, Road and Paving Materials; Paving Management Technologies*, Philadelphia, PA.

American Society for Testing and Materials 1992c

American Society for Testing and Materials. 1992c. 1992 *Annual Book of ASTM Standards, Volume 14.02, General Test Methods, Non-metal; Laboratory Apparatus; Statistical Methods; Durability of Non-Metallitic Materials*, Philadelphia, PA.

American Society for Testing and Materials 1993

American Society for Testing and Materials. 1993. 1993 *Annual Book of ASTM Standards, Volume 04.08, Soil and Rock; Dimension Stone; Geosynthetics*, Philadelphia, PA.

Bell 1987a

Bell, F. G., Editor. 1987a. "Site Investigation," by A. C. Meigh, *Ground Engineer's Reference Book*, Butterworth and Company (Publishers), Ltd., London, England, pp 24/1-24/25.

Bishop 1948

Bishop, A. W. 1948. "A New Sampling Tool for Use in Cohesionless Sands Below Ground Water Level," *Geotechnique*, The Institution of Civil Engineers, London, England, Vol 1, pp 125-131.

Brockett and Lawson 1985

Brockett, Bruce E., and Lawson, Daniel E. 1985. "Prototype Drill for Core Sampling Fine-Grained Perennially Frozen Ground," CRREL Report 85-1, U.S. Army Engineer Cold Regions Research and Engineering Laboratory, Hanover, NH.

Clayton, Simons, and Matthews 1982

Clayton, C. R. I., Simons, N. E., and Matthews, M. C. 1982. *Site Investigation*, Halsted Press, New York, NY.

Decourt et al. 1988

Decourt, L., Muromanchi, T., Nixon, I.K., Schertmann, J.H., Thorburn, S., Zolkov, E., 1988. "Standard Penetration Test (SPT): International Reference Test Procedure," *Penetration Testing 1988*, J. DeRuiter, Ed., A. A. Balkema, Rotterdam, The Netherlands, pp 3-26.

Diamond Core Drill Manufacturers Association, Inc. 1991

Diamond Core Drill Manufacturers Association, Inc. 1991. "DCDMA Technical Manual".

Dowding 1979

Dowding, C. H., Editor. 1979. *Site Characterization and Exploration*, American Society of Civil Engineers, New York, NY.

Dunlap 1980

Dunlap, Wayne A. 1980. Personal Communications, Texas A&M University, College Station, TX.

Gilbert 1984

Gilbert, P. A. 1984. "Investigation of Density Variation in Triaxial Test Specimens of Cohesionless Soil Subjected to Cyclic and Monotonic Loading," Technical Report GL-84-10, U.S. Army Engineer Waterways Experiment Station, Vicksburg, MS.

Goode 1950

Goode, T. B. 1950. "Undisturbed Sand Sampling Below the Water Table," Bulletin No. 35, U.S. Army Engineer Waterways Experiment Station, Vicksburg, MS.

Harder 1993

Harder, Leslie F., Jr. 1993. Personal Communications, California Department of Water Resources, Sacramento, CA.

Harder and Seed 1986

Harder, Leslie F., Jr., and Seed, H. Bolton. 1986. "Determination of Penetration Resistance for Coarse-Grained Soils Using the Becker Penetration Test," EERC Report No. UBC/EERC-86-06, University of California, Berkeley, CA.

Horn 1979

Horn, H. M. 1979. "North American Experience in Sampling and Laboratory Dynamic Testing," *Geotechnical Testing Journal*, American Society for Testing and Materials, Philadelphia, PA., Vol 2, No. 2, pp 84-97.

Hvorslev 1949

Hvorslev, M. Juul. 1949. "Subsurface Exploration and Sampling of Soils for Civil Engineering Purposes," U.S. Army Engineer Waterways Experiment Station, Vicksburg, MS.

Hvorslev and Goode 1960

Hvorslev, M. Juul, and Goode, Thomas B. 1960. "Core Drilling in Frozen Ground," Technical Report No. 3-534, U.S. Army Engineer Waterways Experiment Station, Vicksburg, MS.

International Society for Soil Mechanics and Foundations Engineering 1966

International Society for Soil Mechanics and Foundations Engineering. 1966. "Report of the Subcommittee on Problems and Practices of Soil Sampling," *Proceedings of the Sixth International Conference of Soil Mechanics and Foundation Engineering*, University of Toronto Press, Toronto, Canada, Vol 3, Appendix II, pp 64-71.

Kjellman, Kallstenius, and Wager 1950

Kjellman, W., Kallstenius, T., and Wager, O. 1950. "Soil Sampler with Metal Foils," *Royal Swedish Geotechnical Institute Proceedings*, No. 1, Stockholm, Sweden.

Kovacs and Salomone 1982

Kovacs, William D., and Salomone, Lawrence A. 1982. "SPT Hammer Energy Measurement," *Journal of the Geotechnical Engineering Division*, American Society of Civil Engineers, New York, NY, Vol 108, No. GT4, pp 599-620.

Lange 1963

Lange, G. Robert. 1963. "Refrigerated Fluids for Drilling and Coring in Permafrost," Proceedings of the First Permafrost International Conference, Purdue University, NAS-NRC Publication 1287, pp 375-380.

EM 1110-1-1804
1 Jan 01

Lange 1973a

Lange, G. Robert. 1973a. "An Investigation of Core Drilling in Perennially Frozen Gravels and Rock," Technical Report 245, U.S. Army Engineer Cold Regions Research and Engineering Laboratory, Hanover, NH.

Lange 1973b

Lange, G. Robert. 1973b. "Deep Rotary Core Drilling in Ice," Technical Report 94, U.S. Army Engineer Cold Regions Research and Engineering Laboratory, Hanover, NH.

Longyear Company 1981

Longyear Company. 1981. "Longyear Field Manual - Diamond Tools for Geological Prospecting, Underground Drilling, Grouting, Geothermal Exploration, Hydrological Studies," Product Literature, Minneapolis, MN.

Marcuson and Franklin 1979

Marcuson, W. F., and Franklin, A. G. 1979. "State of the Art of Undisturbed Sampling of Cohesionless Soils," Miscellaneous Paper GL-79-16, U.S. Army Engineer Waterways Experiment Station, Vicksburg, MS.

Mathews 1959

Mathews, A. L. 1959. "Lacquering of Sampling Tubes for Protection Against Corrosion," Technical Report No. 3-514, U.S. Army Engineer Waterways Experiment Station, Vicksburg, MS.

Mathewson 1981

Mathewson, Christopher C. 1981. *Engineering Geology*, Charles E. Merrill Publishing Company, Columbus, OH.

McGraw-Hill, Inc. 1992

McGraw-Hill, Inc. 1992. *McGraw-Hill Encyclopedia of Science and Technology*, McGraw-Hill Publishing Company, New York, NY, 7th Edition, Vol 4, pp 234-234.

Mellor 1976

Mellor, Malcolm. 1976. "Mechanics of Cutting and Boring; Part II: Kinematics of Axial Rotation Machines," CRREL Report No. 76-16, U.S. Army Engineer Cold Regions Research and Engineering Laboratory, Hanover, NH.

Middlebrooks 1942

Middlebrooks, T. A. 1942. "Fort Peck Slide," *Transactions of the American Society of Civil Engineers*, American Society of Civil Engineers, New York, NY, Vol 107, pp 723-764.

N. L. Baroid/N. L. Industries, Inc.

N. L. Baroid/N. L. Industries, Inc., "N. L. Baroid Drilling Fluid Products for Water Well, Minerals Exploration and Geotechnical Drilling," Product Literature, Houston, TX.

Noorany 1989

Noorany, Iraj. 1989. "Classification of Marine Sediments," *Journal of Geotechnical Engineering*, American Society of Civil Engineers, New York, NY, Vol 115, No. 1, pp 23-37.

O'Neil 1934

O'Neil, F. W., Editor, 1934. "Compressed Air Data, Handbook of Pneumatic Engineering Practice," 4th Edition, *Compressed Air Magazine*, Bowling Green Building, New York, NY.

Osterberg and Varaksin 1973

Osterberg, J. O., and Varaksin, Serge. 1973. "Determination of Relative Density Below Groundwater Table," *Evaluation of Relative Density and Its Role in Geotechnical Projects Involving Cohesionless Soils*, ASTM Special Technical Publication 523, American Society for Testing and Materials, Philadelphia, PA, pp 364-376.

Poulos, Castro, and France 1985

Poulos, Steve J., Castro, Gonzalo, and France, John W. 1985. "Liquefaction Evaluation Procedure," *Journal of Geotechnical Engineering*, American Society of Civil Engineers, New York, NY, Vol 111, No. 6, pp 772-792.

Riggs 1986

Riggs, Charles O. 1986. "North American Standard Penetration Test Practice: An Essay," *Use of In Situ Tests in Geotechnical Engineering*, Samuel P. Clemence, Ed., Geotechnical Special Publication No. 6, American Society of Civil Engineers, New York, NY, pp 949-967.

Roberts et al. 1991

Roberts, Freddy L., Kandhal, Prithvi, S., Brown, E. Ray, Lee, Dah-Yinn, and Kennedy, Thomas W. 1991. *Hot Mix Asphalt Materials, Mixture Design, and Construction*, First Edition, NAPA Education Foundation, Lanham, MD.

Sanger 1968

Sanger, Frederick J. 1968. "Ground Freezing in Construction," *Journal of the Soil Mechanics and Foundations Division*, American Society of Civil Engineers, New York, NY, Vol 94, No. SM1, pp 131-158.

Schmertmann 1978

Schmertmann, J. H. 1978. "Use the SPT to Measure Dynamic Soil Properties? - Yes, But...!," *Dynamic Geotechnical Testing*, ASTM Special Technical Publication 654, American Society for Testing and Materials, Philadelphia, PA, pp 341-355.

Schneider, Chameau, and Leonards 1989

Schneider, Hans R., Chameau, Jean-Lou, and Leonards, Gerald A. 1989. "Chemical Impregnation of Cohesionless Soils," *Geotechnical Testing Journal*, American Society for Testing and Materials, Philadelphia, PA., Vol 12, No. 3, pp 204-210.

Seed 1979

Seed, H. Bolton. 1979. "Soil Liquefaction and Cyclic Mobility Evaluation for Level Ground During Earthquakes," *Journal of the Geotechnical Engineering Division*, American Society of Civil Engineers, New York, NY, Vol 105, No. GT2, pp 201-255.

Seed, Idriss, and Arango 1983

Seed, H. Bolton, Idriss, I. M., and Arango, Ignacio. 1983. "Evaluation of Liquefaction Potential Using Field Performance Data," *Journal of Geotechnical Engineering*, American Society of Civil Engineers, New York, NY, Vol 109, No. 3, pp 458-482.

Seed et al. 1982

Seed, H. Bolton, Singh, Sukhmander, Chan, Clarence K., and Vilela, T. F. 1982. "Considerations in Undisturbed Sampling of Sands," *Journal of the Geotechnical Engineering Division*, American Society of Civil Engineers, New York, NY, Vol 108, No. GT2, pp 265-283.

Seed et al. 1985

Seed, H. Bolton, Tokimatsu, K., Harder, L. F., and Chung, Riley M. 1985. "Influence of SPT Procedures in Soil Liquefaction Resistance Evaluations," *Journal of Geotechnical Engineering*, American Society of Civil Engineers, New York, NY, Vol 111, No. 12, pp 1425-1445.

Sellmann and Brockett 1987

Sellmann, Paul V., and Brockett, Bruce E. 1987. "Bit Design Improves Augers," *The Military Engineer*, Alexandria, VA, Vol 79, No. 516, pp 453-454.

Singh, Seed, and Chan 1982

Singh, Sukhmander, Seed, H. Bolton, and Chan, Clarence K. 1982. "Undisturbed Sampling of Saturated Sands by Freezing," *Journal of the Geotechnical Engineering Division*, American Society of Civil Engineers, New York, NY, Vol 108, No. GT2, pp 247-264.

Smith, Dunbar, and Britsch 1986

Smith, Lawson M., Dunbar, Joseph B., and Britsch, Louis D. 1986. "Geomorphological Investigation of the Atchafalaya Basin, Area West, Atchafalaya Delta, and Terrebonne Marsh; Volume I," U.S. Army Engineer Waterways Experiment Station, Vicksburg, MS.

Terzaghi and Peck 1948

Terzaghi, Karl, and Peck, Ralph B. 1948. *Soil Mechanics in Engineering Practice*, John Wiley and Sons, Inc., New York, NY.

Tiedemann and Sorenson 1983

Tiedemann, Drew A., and Sorenson, Raleigh D. 1983. "Use of a Chain Saw for Obtaining Undisturbed Block Samples," *Geotechnical Testing Journal*, American Society for Testing and Materials, Philadelphia, PA., Vol 6, No. 3, pp 157-159.

Torrey, Dunbar, and Peterson 1988

Torrey, Victor H., III, Dunbar, Joseph B., and Peterson, Richard W. 1988. "Retrospective Failures in Sand Deposits of the Mississippi River, Report 1, Field Investigations, Laboratory Studies and Analysis of the Hypothesized Failure Mechanism," Technical Report GL-88-9, U.S. Army Engineer Waterways Experiment Station, Vicksburg, MS.

Tsytoich 1955

Tsytoich, N. A. 1955. "Influence of Freezing Conditions on the Porosity of Water-Saturated Sands," Vop Geol Azii, U.S.S.R. Academy of Science Press.

Ueda, Sellmann, and Abele 1975

Ueda, Herbert, Sellmann, Paul, and Abele, Gunars. 1975. "USA CRREL Snow and Ice Testing Equipment," Special Report 146, U.S. Army Engineer Cold Regions Research and Engineering Laboratory, Hanover, NH.

U.S. Army 1939a

U.S. Army. 1939a. "Notes on Principles and Applications of Soil Mechanics," Corps of Engineers, U.S. Engineer Office, Fort Peck, MT.

U.S. Army 1939b

U.S. Army. 1939b. "Report on the Slide of a Portion of the Upstream Face of the Fort Peck Dam," Corps of Engineers, US Engineer Office, Fort Peck, MT.

U.S. Army Corps of Engineers 1959

U.S. Army Corps of Engineers, Southwestern Division Laboratory. 1959. "Program for Central Procurement of Diamond Drilling Tools," Dallas TX.

U.S. Army Corps of Engineers, Kansas City District 1986

U.S. Army Corps of Engineers, Kansas City District. 1986. "Evaluation of Embankment and Foundation Earthquake Resistance," Design Memorandum No 35, Seismic Evaluation, Milford Dam, Republican River, Kansas, Kansas City, MO.

U.S. Army Engineer Waterways Experiment Station 1952

U.S. Army Engineer Waterways Experiment Station. 1952. "Density Changes of Sand Caused by Sampling and Testing," Potamology Investigations Report No. 12-1, Vicksburg, MS.

U.S. Army Engineer Waterways Experiment Station 1960

U.S. Army Engineer Waterways Experiment Station. 1960. "The Unified Soil Classification System," Technical Memorandum No. 3-357, Vicksburg, MS.

U.S. Department of the Interior, Bureau of Reclamation 1974

U.S. Department of the Interior, Bureau of Reclamation. 1974. *Earth Manual*, 2nd Ed., Washington, D.C.

U.S. Department of the Interior, Bureau of Reclamation 1986

U.S. Department of the Interior, Bureau of Reclamation. 1986. "Procedure for Performing Disturbed Soil Sampling in Test Pits, Trenches, Accessible Borings, and Tunnels," USBR 7000-86, Denver, CO.

Vallee and Skryness 1979

Vallee, R. P., and Skryness, R. S. 1979. "Sampling and In Situ Density of a Saturated Gravel Deposit," *Geotechnical Testing Journal*, American Society for Testing and Materials, Philadelphia, PA., Vol 2, No. 3, pp 136-142.

Walberg 1978

Walberg, Francke C. 1978. "Freezing and Cyclic Triaxial Behavior of Sands," *Journal of the Geotechnical Engineering Division*, American Society of Civil Engineers, New York, NY, Vol 104, No. GT5, pp 667-671.

EM 1110-1-1804
1 Jan 01

Winterkorn and Fang 1975

Winterkorn, H. F., and Fang, H. Y., Editors. 1975. "Subsurface Explorations and Sampling" by John Lowe, III, and Philip F. Zacheo, *Foundation Engineering Handbook*, Van Nostrand Reinhold Company, New York, NY, pp 1-66.

Yoshimi, Hatanaka, and Oh-oka 1978

Yoshimi, Y., Hatanaka, M., and Oh-oka, H. 1978. "Undisturbed Sampling of Saturated Sands by Freezing," *Soils and Foundations*, Japanese Society of Soil Mechanics and Foundation Engineering, Tokyo, Japan, Vol 18, No. 3, pp 59-73.

A-3. Bibliography

American Society for Testing and Materials 1972

American Society for Testing and Materials. 1972. *Underwater Soil Sampling, Testing and Construction Control*, ASTM Special Technical Publication 501, Philadelphia, PA.

Begemann 1974

Begemann, H. K. S. 1974. "The Delft Continuous Soil Sampler," *Bulletin of the International Association of Engineering Geology*, Laboratoire Central des Ponts et Chaussées, Paris, France, No. 10, pp 35-37.

Bell 1987b

Bell, F. G., Editor. 1987b. "Artificial Freezing of the Ground for Construction Purposes," by H. L. Jessberger, *Ground Engineer's Reference Book*, Butterworth and Company (Publishers), Ltd., London, England, pp 31/1-31/17.

Canadian Geotechnical Society 1985

Canadian Geotechnical Society. 1985. *Canadian Foundation Engineering Manual*, 2nd Ed., Vancouver, British Columbia, Canada.

Chaney and Demars 1985

Chaney, Ronald C., and Demars, K. R., Editors. 1985. *Strength Testing of Marine Sediments: Laboratory and In-Situ Measurements*, ASTM Special Technical Publication 883, American Society for Testing and Materials, Philadelphia, PA.

Chapman 1964

Chapman, Charles F. 1964. *Piloting, Seamanship, and Small Boat Handling*, 1965-66 Edition, The Hearst Corporation, New York, NY.

Christensen Diamin Tools, Inc.

Christensen Diamin Tools, Inc. "An Overview - Drilling with Diamonds," Product Literature, Salt Lake City, UT.

Department of the Navy, Naval Facilities Engineering Command 1982

Department of the Navy, Naval Facilities Engineering Command. 1982. "Soil Mechanics," Design Manual NAVFAC DM-7.1, Arlington, VA.

Departments of the Army and the Air Force 1982

Departments of the Army and the Air Force. 1982. "Soils and Geology, Procedures for Foundation Design of Buildings and Other Structures (Except Hydraulic Structures)," Technical Manual No. 5-818-1/AFM 88-3, Washington, D.C.

Emrich 1971

Emrich, W. J. 1971. "Performance Study of Soil Sampler for Deep Penetration Marine Borings," *Sampling of Soil and Rock*, ASTM Special Technical Publication 483, American Society for Testing and Materials, Philadelphia, PA, pp 30-50.

Finn 1972

Finn, Fred N. 1972. "Subsurface Soils Exploration," National Association of County Engineers Action Guide Series, Vol 16.

Gray 1971

Gray, George R. 1971. "Plan the Mud Program to Reduce Exploration Cost," Preprinted by *Western Miner*, Vancouver, British Columbia, Canada.

Gray 1972

Gray, George R. 1972. "Drilling with Mud - Simple Tests Save Time and Money," Reprinted from *Water Well Journal*.

Harder 1987

Harder, Leslie F., Jr. 1987. "Interpretation of Becker Penetration Tests Performed at Ririe Dam in 1986," Appendix H, "Seismic Stability Evaluation of Ririe Dam and Reservoir Project, Report 1, Construction History and Field and Laboratory Studies, Volume II: Appendixes A-J," by D. W. Sykora et al. 1991, Technical Report GL-91-22, U.S. Army Engineer Waterways Experiment Station, Vicksburg, MS.

International Society for Soil Mechanics and Foundations Engineering 1981

International Society for Soil Mechanics and Foundations Engineering. 1981. *International Manual for the Sampling of Soft Cohesive Soils*, Sub-Committee on Soil Sampling, Ed., Tokai University Press, Tokyo, Japan.

Iskandar 1987

Iskandar, Iskandar K. 1987. "Ground Freezing Controls Hazardous Waste," *The Military Engineer*, Alexandria, VA, Vol 79, No. 516, pp 455-456.

Jewell and Khorshid 1988

Jewell, R. J., and Khorshid, M. S., Editors. 1988. *Engineering for Calcareous Sediments*, A. A. Balkema, Rotterdam, Netherlands, Vol I and II.

Ling 1972

Ling, S. C. 1972. "State-Of-The-Art of Marine Soil Mechanics and Foundation Engineering," Technical Report S-72-11, U.S. Army Engineer Waterways Experiment Station, Vicksburg, MS.

Maurer 1980

Maurer, William C. 1980. *Advanced Drilling Techniques*, The Petroleum Publishing Company, Tulsa, OK.

EM 1110-1-1804
1 Jan 01

Mitchell, Guzikowski, and Villet 1978

Mitchell, James K., Guzikowski, Frank, and Villet, Willem C. B. 1978. "The Measurement of Soil Properties In-Situ," Lawrence Berkeley Laboratory Report No. LBL-6363, University of California, Berkeley, CA.

Proctor 1933

Proctor, R. R. 1933. "Description of Field and Laboratory Methods," *Engineering News-Record*, McGraw-Hill Publishing Company, New York, NY, Vol 111, No. 9, pp 286-289.

Rand and Mellor 1985

Rand, John, and Mellor, Malcolm. 1985. "Ice-Coring Augers for Shallow Depth Sampling," CRREL Report 85-21, U.S. Army Engineer Cold Regions Research and Engineering Laboratory, Hanover, NH.

Rocker 1985

Rocker, Karl Jr., Editor. 1985. "Handbook for Marine Geotechnical Engineering," U.S. Naval Civil Engineering Laboratory, Port Hueneme, CA, pp 2 1 to 2 28.

Sellmann and Mellor 1986

Sellmann, Paul V., and Mellor, Malcolm. 1986. "Drill Bits for Frozen Fine-Grained Soils," Special Report 86-27, U.S. Army Engineer Cold Regions Research and Engineering Laboratory, Hanover, NH.

Stanley and Swift 1976

Stanley, Daniel Jean, and Swift, Donald J. P., Editors. 1976. *Marine Sediment Transport and Environmental Management*, John Wiley & Sons, New York, NY.

Texas Highway Department, The Bridge Division 1972

Texas Highway Department, The Bridge Division. 1972. "Foundation Exploration and Design Manual," 2nd Ed., Austin, TX.

Thurman 1987

Thurman, Harold V. 1987. *Essentials of Oceanography*, 2nd Edition, Charles E. Merrill Publishing Company, Columbus, OH.

U.S. Army Corps of Engineers, South Atlantic Division 1985

U.S. Army Corps of Engineers, South Atlantic Division. 1985. "Engineering and Design Geotechnical Manual for Surface and Subsurface Investigations," Division Manual DM 1110-1-1, Atlanta, GA.

U.S. Army Engineer Waterways Experiment Station 1982

U.S. Army Engineer Waterways Experiment Station. 1982. "Earthwork Construction Inspectors Course," PROSPECT Training Course Notes, Vicksburg, MS.

U.S. Army Engineer Waterways Experiment Station 1984

U.S. Army Engineer Waterways Experiment Station, Coastal Engineering Research Center. 1984. "Shore Protection Manual," Vol I and II, Vicksburg, MS.

U.S. Army Engineer Waterways Experiment Station 1986

U.S. Army Engineer Waterways Experiment Station. 1986. "Drilling and Sampling for Engineering Purposes," PROSPECT Training Course Notes, Vicksburg, MS.

U.S. Department of the Interior, Bureau of Reclamation 1989

U.S. Department of the Interior, Bureau of Reclamation. 1989. "Procedure for Obtaining Undisturbed Block Samples by the Hand and Chain Saw Methods," USBR 7100-89, Denver, CO.

Wright 1983

Wright, Stephen G., Editor. 1983. *Geotechnical Practice in Offshore Engineering*, American Society of Civil Engineers, New York, NY.

Appendix F-2 (of EM 1110-1-1906) Artificial Ground Freezing for Undisturbed Sampling of Cohesionless Soils

D-1. Introduction

The critical importance of high-quality undisturbed samples of cohesionless soils for earthquake analysis procedures has been well documented (Horn 1979; Marcuson and Franklin 1979; Poulos, Castro, and France 1985; Seed 1979; Singh, Seed, and Chan 1982).¹ Unfortunately, the development of technology or methodologies to obtain truly undisturbed samples of sand has been rather elusive. Hvorslev (1949) suggested several methods which included thin-walled, fixed-piston samplers in mud-filled holes; open-drive samplers using compressed air; freezing; and impregnation. Marcuson and Franklin (1979) and the U.S. Army Engineer Waterways Experiment Station (1952) reported studies using the thin-walled, fixed-piston sampler; these studies documented that loose samples were densified and dense samples were loosened. Seed et al. (1982) reported an investigation of the effect of sampling disturbance on the cyclic strength characteristics of sands; they reported that the Hvorslev fixed-piston sampler caused density changes while advance trimming and sampling techniques caused little change in density, although some disturbance due to stress relief was reported. Other methods have included hand-trimming samples from test pits or shafts. Occasionally, samples obtained by fixed-piston sampling or hand-trimming methods have been frozen after sampling at the site (Torrey, Dunbar, and Peterson 1988; Walberg 1978) in an attempt to preserve the sample. However, studies have consistently demonstrated that stress relief and/or void ratio changes may have occurred during sampling operations.

More recently, studies have demonstrated that high quality undisturbed samples could be obtained by impregnation or freezing techniques, although both methods were fairly expensive and difficult to apply. A study using the impregnation technique was reported by Schneider, Chameau, and Leonards (1989). The premiere consideration of this study was the concern that the impregnating material would readily penetrate the soil, protect the soil structure during sampling operations, and could easily and effectively be removed from the specimen at a later date. Singh, Seed, and Chan (1982) reported a laboratory investigation which employed an "in situ" freezing technique. For this study, a large triaxial specimen of sand which had been subjected to a known stress history was frozen and sampled; the experimental data demonstrated that unidirectional freezing with no impedance of drainage could be used to obtain laboratory samples which maintained the characteristics of the in situ formation.

Based upon the research by Singh, Seed, and Chan (1982), a methodology, which consists of one-dimensional ground freezing followed by core sampling, should be considered whenever very high-quality undisturbed samples of cohesionless materials are required. The in situ freezing method is contingent on the requirements that the soil is free draining and that the freeze front advances one-dimensionally; the one-dimensional movement of the freeze front permits drainage away from the front in response to the change of volume caused by the phase change of water to ice.

D-2. Historical Development

Ground freezing for construction purposes has been conducted for more than 100 years (Sanger 1968). In situ freezing to obtain undisturbed calyx samples was done at Fort Peck Dam following the upstream slide of the embankment in 1938 (Middlebrooks 1942; U.S. Army 1939a, 1939b; Hvorslev 1949). Other

¹ References cited in this appendix are included in Appendix A.

instances of ground freezing have included operations to obtain in-place densities in sands, gravelly sands, and gravels (Osterberg and Varaksin 1973, Vallee and Skryness 1979). For each of these operations, a cylindrical-wall freezing technique was employed. Because one-dimensional freezing was not satisfied, specimens may have been disturbed as a result of ice expansion.

More recently, Japanese investigators (Yoshimi, Hatanaka, and Oh-oka 1978) reported an in situ radial freezing technique. The methodology consisted of the use of a single freeze pipe which is subsequently used to pull a frozen column of soil from the ground. While the “popsicle” technique satisfied the one-dimensional freezing criteria, it is likely the technique is limited to shallow depths and would not be appropriate for many locations, such as the downstream toe of a dam where the piezometric levels may be very high. A one-dimensional freezing technique which allows sampling at depths greater than 15 m (50 ft) which should not jeopardize the structural safety of the dam or embankment is presented herein.

D-3. In Situ Freezing and Testing Rationale

a. Site selection and layout. As previously mentioned, a site must be selected in which the soil is freedraining; the freeze hole layout must be designed to ensure that the freeze front advances across the prospective sampling area in one dimension without trapping water. Although this in situ freezing procedure is generally applicable to saturated, relatively clean sands and gravels, it could be used in partially saturated materials provided that sufficient ice is formed during the freezing process to give the material adequate strength (cohesion) to allow coring. The presence of too many fines (silts and clays) could result in impeded drainage, in which the pore water would expand during the phase change to ice and seriously disturb the sand structure, or could cause migration of pore water toward the freeze front, which would result in the formation of ice lenses with subsequent volume change. In either case, Tsyto- vich (1955) and Gilbert (1984) have shown that in sands with free drainage, the porosity remains constant because excess water is squeezed out as the freeze front advances.

Provided that a suitable candidate site has been identified, typical examples of a site layout are illustrated in Figures D-1 and D-2. According to the literature, spacings for the holes are typically 0.6 to 0.9 m (2 to 3 ft), although Vallee and Skryness (1979) reported a hole spacing of 2.1 m (7 ft). Initially, a coolant, such as a chilled brine, is circulated through vertical freeze holes identified by the symbol “F.” Freezing progresses radially from each hole and eventually makes closure between the freeze holes to form a continuous frozen mass, as idealized in the figures. The location of the freeze front can be determined by symmetry from monitoring the temperature in holes identified by the symbol “T.”

If additional freeze holes are needed to obtain a thick mass of ice around the proposed sampling area, circulation of the coolant in the secondary freeze holes should not begin until freezing of the initial area is completed. Furthermore, the layout of the freeze holes should ensure that freezing will always progress radially outward from the initial freeze zone. If one-dimensional freezing does not occur, disturbance of the soil in zones between the freeze fronts may occur because of the expansion of groundwater upon freezing. Additionally, freeze holes and temperature monitoring holes should be located as far as practical from the sampling area to minimize the disturbance caused by drilling and installation of the holes.

b. Coring. Based upon experience obtained by drilling in frozen soil, coring methods vary with the type of soil, its temperature, and the degree of saturation of ice in the soil voids, i.e., the ice content (Hvorslev and Goode 1960). Soil strength increases with a decrease of temperature and an increase of the ice content, whereas the torsional strength of a core of frozen soil increases with increasing diameter. To obtain good cores and good recovery, a fairly large, e.g., 125- to 150-mm- (5- to 6 in.-) diam double-

or triple-tube core barrel with a diamond or tungsten bit is suggested. Because the temperature of the artificially frozen soil can be expected to be only a few degrees below freezing, the drilling fluid will have to be cooled to prevent the melting of the pore ice during the drilling operations. Cooling of the drilling fluid can be accomplished by circulating it through a chiller attached to the refrigeration plant. Although the use of air as the drilling fluid is perhaps more desirable from an environment consideration, it is not satisfactory if the ambient air temperature is above freezing. Furthermore, the use of compressed air as a drilling fluid is prohibited for drilling in water-retaining embankments, as outlined by ER 1110-2-1807. Consequently, the alternative choices for drilling fluid are ethylene or propylene glycol and diesel fuel, although the potential adverse environmental effects caused by these products must be considered.

c. Frozen core. Immediately after the core has been retrieved from the borehole, it should be moved to a cold storage facility where it can be identified, logged, and sealed in a container which will prevent sublimation of ice as well as protect the sample when it is transported to and stored at the laboratory. Once the samples have arrived at the laboratory, further testing can be conducted under more controlled conditions and at much colder temperatures. For example, if the grain size of the material is small enough, samples may be recored to smaller diameter specimens; this operation will tend to eliminate the effects of any disturbance from field coring and/or thawing at the periphery of the field sample. After the frozen specimen has been prepared for testing, it can be placed in the triaxial chamber where the in situ stresses and pore pressure can be reapplied prior to permitting the specimen to thaw. During the thawing process, the specimen should be continuously monitored to detect any evidence of disturbance. After the thawing process is completed and the temperature of the test specimen has stabilized with the ambient conditions, monotonic or cyclic triaxial tests can be performed to determine the in situ static or dynamic strength properties, respectively.

D-4. Freeze Plant System

Although there is not a “best” or unique system for conducting the in situ freezing and drilling and sampling operations, the design of a suitable freeze plant system can be accomplished by cooperation of refrigeration personnel who are knowledgeable of artificial ground freezing operations and geotechnical personnel who are knowledgeable of the site conditions. In principle, the freeze plant system consists of three separate systems. The refrigerator system which is similar to a refrigerator or freezer home appliance consists of a motor, compressor, condenser, and evaporator. The freeze hole system consists of a chiller, a reservoir for storage of the chilled drilling fluid, a brine pump, and the pipe for circulating the chilled brine to the freeze holes. The monitoring or data acquisition system includes pressure, temperature, and flow rate sensors.

a. Freeze plant. The purpose of the freeze plant is to cool the brine, which is circulated through the freeze holes, to a temperature much less than 0 deg C (32 deg F) as well as to chill the drilling fluid sufficiently to prevent thawing of the core during drilling operations. During field operations, the brine is cooled in the chiller by the refrigeration system, circulated through the freeze pipes by the brine pump, returned to the refrigeration plant, and recirculated through the chiller; a similar technique is used for cooling the drilling fluid. Considerations for the design of the freeze plant should include: seepage in the foundation could require a large amount of energy to freeze the formation; and the use of two smaller refrigeration plants, i.e., one for in situ freezing and one for chilling the drilling fluid, would allow more flexibility of the field operations as compared to one large plant. From data published in the cited literature, the refrigerator plants were typically 30 to 60 kilowatts (kw) (100,000 to 200,000 BTU/hr or 8.5 to 17.0 tons), although one system was reported as 260 kw (890,000 BTU/hr or 74.0 tons).

b. Freeze holes and temperature holes. Freeze holes and temperature monitoring holes can be drilled and constructed identically, except that temperature monitoring holes do not have to be fitted for brine recirculation. Holes should be drilled slightly larger in diameter than the diameter of the pipes to be placed in the holes. To ensure the vertical alignment of all holes, which is fairly critical, the kelly can be plumbed by sighting through a transit. For example, nonvertical freeze holes could result in a pocket or window of unfrozen material within the frozen mass or the intrusion of freeze holes into the desired sample area. Similarly, the vertical alignment of temperature holes assures that monitored temperatures are always taken at a constant distance from the freeze pipes.

Upon completion of the drilling, freeze or temperature monitoring pipes, which have been previously pressure tested for leakage, can be installed in the borehole. Prior to backfilling the annulus between the pipe and the walls of the borehole with granular material, the vertical deviation of each pipe should be measured by a suitable device, such as a borehole inclinometer. After the boreholes have been backfilled, each freeze pipe can be fitted with valves, insulated supply and return lines, and other equipment or gauges which are required for operation of the system. From the literature, the pipes used in the freeze holes were typically 8 to 10 cm (3 to 4 in.) in diameter while the pipes used in the temperature holes were either the same diameter or slightly smaller.

c. Monitoring system. To monitor system operations, a variety of instruments is required. Brine pressures and flow rates should be monitored at the pump (supply line) and before the chiller (return line). The refrigeration plant compressor head pressure and suction pressure should also be monitored. Thermocouples or other suitable temperature monitoring devices should be installed at several locations along the coolant supply and return lines, such as immediately ahead of and behind each freeze hole. A string of thermocouples should be suspended in the brine-filled temperature monitoring pipes at regular intervals, e.g., approximately 1.2- to 1.5-m (4- to 5-ft) intervals, to monitor the cooling and subsequent freezing of the formation. The thermocouples can be connected to a multiple-switch monitoring box with a digital thermometer. All operations data should be routinely recorded at regular intervals, e.g., every 4 hr.

D-5. Undisturbed Sampling Operations

a. Coring. Coring can be accomplished using a conventional double- or triple-tube core barrel equipped with a diamond or tungsten bit. The drilling fluid is cooled by circulating it through a heat exchanger connected in parallel to the refrigeration plant; a time of 1 or 2 hr or more may be required to reduce the temperature of the drilling fluid to below freezing before drilling operations can begin. Although drilling operations must be tempered to the site-specific conditions, it is suggested that rapid penetration of the bit at high revolutions per minute (rpm) will usually produce the best quality samples. Because the frozen ground and drilling fluid temperatures are usually not low enough to prevent thawing of the outermost periphery of the sample during drilling and sampling operations, it is probable that lower penetration rates will generally result in more thawing at the periphery of the core and consequently more erosion of the core by the circulating drill fluid. See Chapter 9 for additional information on sampling frozen soils.

b. Handling of core. The length of the core run is dependent upon the dimensions of the core barrel and may be several feet. As soon as the core is taken from the core barrel, it should be placed in a sturdy cradle and carried to a refrigerated van where it can be logged, photographed, and cut into shorter lengths. Cutting of the core can be accomplished by a band saw or a hammer and chisel. The cut core should then be wrapped in two or three layers of plastic wrap followed by two or three layers of aluminum foil and then carefully sealed with strapping tape to prevent sublimation of the ice. After each

segment of core has been sealed, it should be placed in a suitable container, such as a section of split PVC pipe, and secured by strapping tape for transport to the laboratory and subsequent storage. The sample should then be identified and boring logs should be updated. See Chapter 13 for guidance on the handling and storage of samples and maintaining sampling records.

D-6. Precautions

Because of limited experience of the profession regarding in situ freezing, each investigation must be tailored to the site conditions. Therefore, comprehensive guidance and rules governing in situ freezing cannot be established for specific situations. However, several precautions are identified which may enhance the field operations.

- The candidate formation should be free draining and relatively free of silt and clay (lenses) which could result in impeded drainage or migration of water towards the freeze front. Unfortunately, this same characteristic may also cause unanticipated freezing difficulties due to the large seepage gradients or velocities in the formation.
- The freeze hole layout and spacing should be optimized for the foundation conditions. Prior to installation, freeze pipes and temperature pipes should be checked for leaks. Care should be exercised to ensure that one-dimensional freezing of the formation occurs. This operation can be enhanced by carefully drilling vertical freeze holes and checking the verticality of the freeze pipes prior to backfilling the holes.
- The temperature of the brine used in the freeze holes should be monitored at several locations along the pipes of the freeze system, such as at the chiller and the return from each hole. Similarly, the temperature of the brine in the temperature holes should be monitored at selected depths and at regular time intervals to determine the passage of the freeze front.
- The efficiency of the freeze plant operations should be optimized by adjusting the flow rate of the brine and the corresponding temperature, or temperature change, to obtain the maximum energy exchange with the formation. However, care is needed when the method for optimizing the system efficiency is selected. For example, in an effort to increase the rate of freezing of a sand formation at a site in Kansas (U.S. Army Corps of Engineers, Kansas City District 1986), liquid carbon dioxide (CO₂) was injected into the brine. Although the temperature of the brine was reduced 5 to 10 deg C (10 to 20 deg F) by the addition of liquid CO₂, the highly corrosive CO₂ and brine mixture resulted in adverse effects on the freezing operations. Pipe scale clogged the brine chiller and thus caused high pressure losses, damage to brine pump, and excessive maintenance.
- Sampling should be conducted in an area located as far as practical from the freeze holes and temperature monitoring holes to minimize the disturbance caused by the installation of the in situ freezing system. Drilling and sampling should be accomplished as rapidly as possible to minimize thawing and erosion of the core. Two options are available to enhance quality of the frozen core. Since the ice content of the frozen core is independent of the artificial freezing techniques which are employed, the torsional strength can be increased only by decreasing the temperature of the pore ice or increasing the diameter of the core. A refrigerated van, or comparable facility, is needed at the site for logging, sealing, and storage of the frozen cores prior to shipment to the laboratory. After the cores have been received at the laboratory, tests

EM 1110-1-1804

1 Jan 01

should be conducted to determine if the soil has been contaminated by the drilling fluid and the effect(s) of the contamination on the engineering properties of the soil.

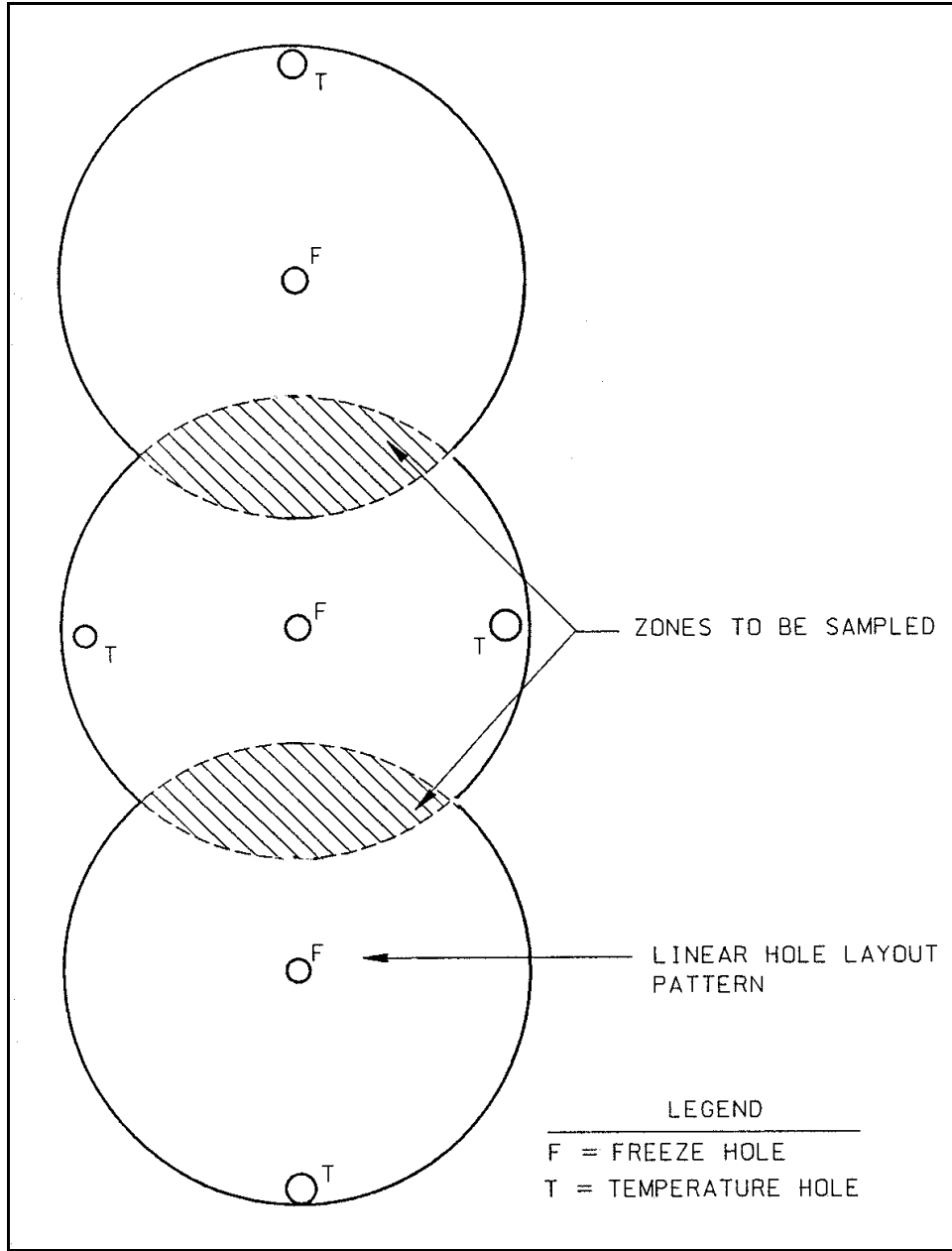

Figure D-1. Linear layout of freeze holes and temperature holes

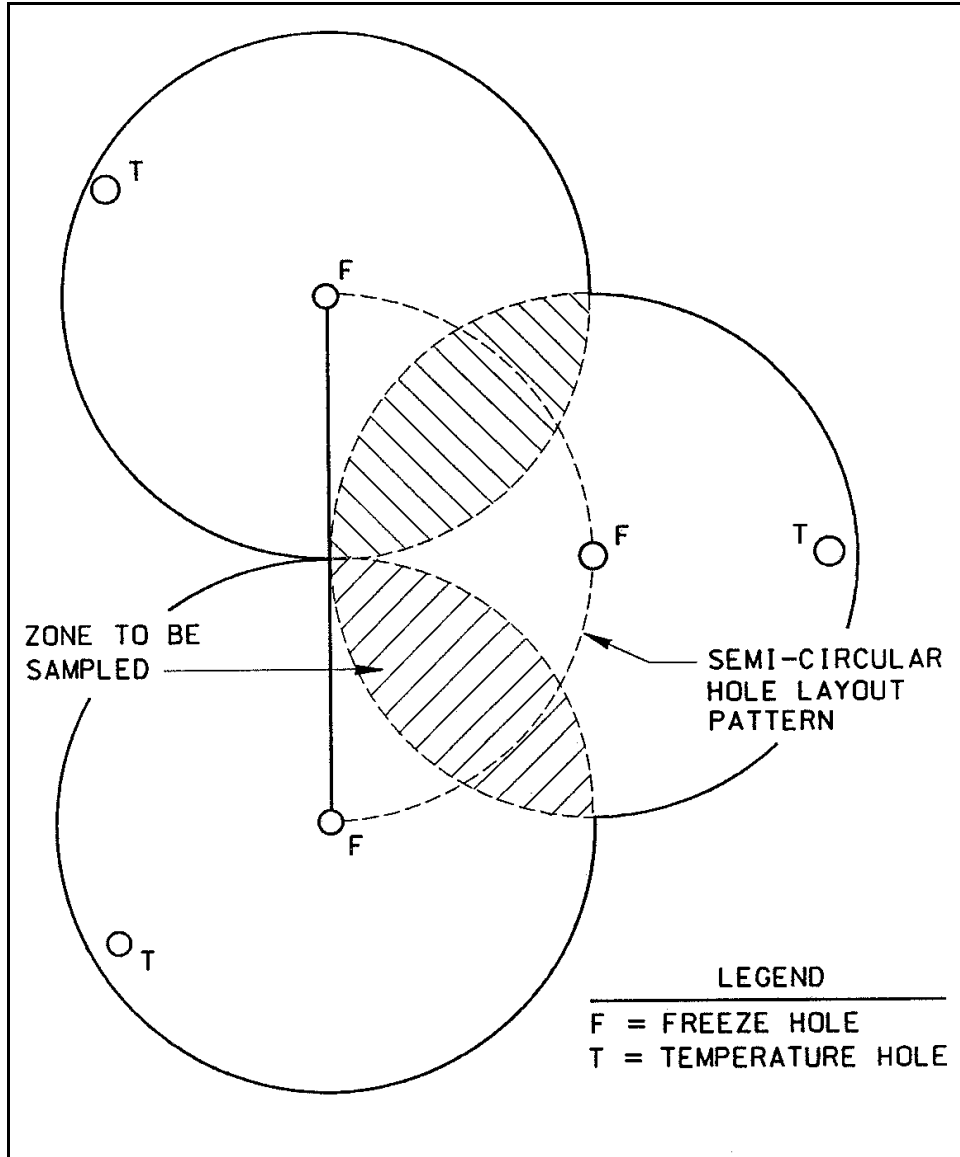

Figure D-2. Semicircular layout of freeze holes and temperature holes

Appendix F-3 (of EM 1110-1-1906) Visual Identification of Soil Samples

E-1. Field Identification Techniques

Visual identification techniques reported herein generally yield results which are consistent with the Unified Soil Classification System (ASTM D 2487, 1993; ASTM D 2488, 1993; U.S. Army Engineer Waterways Experiment Station, 1960).¹ Because these techniques are primarily visual, subtle discrepancies may exist between the identifications obtained in the field and the classifications determined in the laboratory. However, the results are meaningful provided the inspector makes careful and consistent identifications. See Chapter 13 for details on handling and storage of samples and maintaining sampling records. The inspector's equipment required to conduct these tests is limited to a pocket knife, scale, magnifying glass, and a small container of diluted hydrochloric acid. Table E-1 can be used as a checklist for conducting a systematic visual identification of a soil sample; it is also useful for locating the appropriate table and/or figure which describe(s) a test procedure for visually identifying the soil.

E-2. Grain Size

The inspector must first determine whether the material is coarse grained or fine grained. To make this determination, spread a representative sample on a flat surface. Determine whether or not the predominant size fraction is discernible with the naked eye. Coarse-grained soils vary from particles in excess of 75 mm (3 in.) in diameter to particles just discernible with the unaided eye, such as table salt or sugar, whereas fine-grained soils are microscopic and submicroscopic. The predominant material of peat or muck is decaying vegetation matter. Table E-2 and Figure E-1 may aid in determining the grain size of the soil in question. If the predominant material is coarse grained, follow the procedures outlined in paragraph E-2a; if the soil is fine grained, follow the procedures outlined in paragraph E-2b.

a. *Coarse-grained soils.*

(1) *Coarse fraction.* Once the soil has been determined to be coarse grained, further examination is required to determine the grain size distribution, the grain shape, and the density of the in situ deposit (if applicable). The gradation of coarse-grained soils can be described as well graded, poorly graded, or gap graded.

Table E-3 and Figure E-2 can be used in selecting the appropriate descriptive terms. Soil particles can also be described according to a characteristic shape. Particle shape may vary from angular to rounded to flat or elongated. Appropriate descriptive terms are listed in Table E-4; particle shapes are illustrated in Figure E-3. The density of an in situ deposit of a coarse-grained soil is also valuable information. Results obtained by pushing a reinforcing rod into a surface deposit or from the Standard Penetration Test may indicate the density of an in situ deposit. Appropriate descriptive terms may be selected from Table E-5.

(2) *Fine fraction.* The plasticity characteristics of the fine fraction of a coarse-grained material also need to be determined. The tests for fine-grained soils (paragraph E-2b) which are described in

¹ References cited in this appendix are included in Appendix A.

Table E-6 and illustrated in Figures E-4 through E-10 can be used to characterize the fine fraction of the soil sample in question.

b. Fine-grained soils.

(1) *Coarse fraction.* The coarse-grained fraction, where applicable, should be described in terms of the size of the predominate grain size, i.e., sand or gravel. Paragraph E-2a, Table E-2, and Figure E-1 may aid in selecting appropriate descriptive terms.

(2) *Fine fraction.* Several tests may be useful in determining the plasticity characteristics of fine-grained soils or fractions thereof; these tests include the dilatancy or reaction to shaking test, the dry strength test, and the toughness and plasticity tests. For each test, the fraction which passes the No. 40 U.S. Standard Sieve (0.42 mm) is used; this fraction corresponds to the fraction which is required for determination of Atterberg limits. For the purpose of the visual tests, however, screening is not important; the removal of coarse particles is adequate. Tests to determine the plasticity characteristics of the fine fraction are described in Table E-6, the dilatancy test is illustrated in Figures E-4 through E-7, the dry strength test is presented in Figure E-8, and toughness and plasticity tests are given in Figures E-9 and E-10, respectively.

c. Other tests. The dispersion (settlement in water) test and the bite test can be used to determine the presence of and relative amounts of sand, silt, and clay fractions (see Table E-6). Several other tests, such as the odor and the peat tests for determining the presence of organic matter, the acid test for determining the presence of a calcium carbonate cementing agent, and the slaking test for determining whether the “rocklike” material is shale, are listed in Table E-6. Strength descriptors of a clay sample are listed in Table E-7.

E-3. Soil Moisture and Color

Soil moisture and color are important indicators of soil conditions. For example, visible or free water from a soil sample can infer the proximity of a water table. The color of a moist soil sample tells much about the minerals and chemicals present in the soil, the drainage conditions, and the presence of organic matter. Soil color charts prepared for the U.S. Department of Agriculture (USDA) by the Munsell Color Company, New Windsor, NY 12553, are helpful for describing the color of soil samples. Soil moisture conditions or water contents can be described following the criteria presented in Table E-8. The importance of color for identifying and classifying moist fine-grained soils is shown in Table E-9.

E-4. Mass Structure and Mass Defects of Soil Formations

Mass structure and mass defects yield data about the geotechnical engineering behavior of a soil formation in question. For example, a varved clay would most likely have different engineering properties from an homogeneous deposit of one of the constituent soils. Likewise, slickensides indicate a clay deposit has been overconsolidated because of desiccation, surcharge loading, or both; an overconsolidated clay would have different engineering properties from a normally consolidated deposit of the same material. Descriptive terms for mass structure and mass defects of a soil formation are presented in Tables E-10 and E-11, respectively.

E-5. Description of Soils

As presented in the footnote in Table E-1, the description of a soil sample should contain appropriate terms to characterize the soil type and grain size, its moisture content and color, and mass structure and defects. Commonly used names and descriptions for selected soils are presented in Table E-12.

Table E-1
Order of Description for Soils

| Criteria | Table No. | Figure No. |
|--------------------------------------------------------------|-----------|------------|
| Soil types and particle sizes | E-2 | E-1 |
| Coarse-grained soils | | |
| Description of gradation of coarse-grained soils | E-3 | E-2 |
| Description of grain shape of coarse-grained soils | E-4 | E-3 |
| Density of coarse-grained soils | E-5 | |
| Fine-grained soils | | |
| Field identification procedures for fine-grained soils | E-6 | E-4/E-10 |
| Strength or consistency of clays | E-7 | |
| Moisture content | E-8 | |
| Role of color for identification of moist fine-grained soils | E-9 | |
| Terms for describing mass structure of soils | E-10 | |
| Terms for describing mass defects in soil structure | E-11 | |
| Commonly used descriptive soil names | E-12 | |

Example: Sand, fine, silty, tan, poorly-graded, dense, wet, subrounded, very friable with occasional clay lenses.

Table E-2
Soil Types and Particle Sizes

| Principal Soil Type | Descriptive Term | Size | U.S. Standard Sieve | Familiar Example |
|----------------------|------------------|--------------------------------|---------------------|-----------------------------|
| Coarse-grained Soils | Cobble | 76 mm or larger | Greater than 3 in. | Grapefruit or orange |
| | Coarse gravel | 76 mm to 19 mm | 3 in. to 3/4 in. | Walnut or grape |
| | Fine gravel | 19 mm to 5 mm | 3/4 in. to #4 | Pea |
| | Coarse sand | 5 mm to 2 mm | #4 to #10 | Rock salt |
| | Medium sand | 2 mm to 0.4 mm | #10 to #40 | Openings of a window screen |
| | Fine sand | 0.4 mm to 0.074 mm | #40 to #200 | Table salt or sugar |
| Fine-grained Soils | Silt or clay | Microscopic and submicroscopic | | |
| Organic | Peat or muck | | | Decaying vegetable matter |

Note: Particles which are retained on the No. 200 U.S. Standard Sieve (0.074 mm) can just be discerned with the naked eye at a distance of about 25 cm (10 in.).

EM 1110-1-1804
1 Jan 01

Table E-3
Description of Gradation of Coarse-Grained Soils

| Descriptive Term | Meaning |
|----------------------------|-----------------------------------------------------|
| Well graded | A good representation of all grain sizes is present |
| Uniformly or poorly graded | All grains are approximately the same size |
| Gap graded | Intermediate grain sizes are absent |

Table E-4
Description of Grain Shape of Coarse-Grained Soils

| Descriptive Term | Example |
|------------------|--------------------------------------------------------|
| Angular | Irregular with sharp edges such as freshly broken rock |
| Subangular | Irregular with smooth edges |
| Subrounded | Irregular but smooth as a lump of molding clay |
| Rounded | Marble or egg shaped, very smooth |
| Flaky | Sheet of paper or flake of mica |
| Flat | Ratio of width to thickness greater than 3 |
| Elongated | Ratio of length to width greater than 3 |

Table E-5
Density of Coarse-Grained Soils

| Descriptive Term | Blows per Foot ^{1,2} | Field Test |
|------------------|-------------------------------|--------------------------------------------------------------------------------------------------------------------|
| Very loose | Less than 4 | ----- |
| Loose | 4-10 | Easily penetrated with a 13-mm- (1/2-in.-) diam reinforcing rod pushed by hand |
| Medium dense | 10-30 | Easily penetrated with a 13-mm- (1/2-in.-) diam reinforcing rod driven with a 2.3-kg (5-lb) hammer |
| Dense rod | 30-50 | Penetrated 0.3 m (1 ft) with a 13-mm- (1/2-in.-) diam reinforcing rod driven with a 2.3-kg (5-lb) hammer |
| Very dense | Greater than 50 | Penetrated only a few centimeters with a 13-mm- (1/2-in.-) diam reinforcing rod driven with a 2.3-kg (5-lb) hammer |

¹ From SPT (Appendix B, Table B-1).

² 1 ft = 0.3048 m.

Table E-6
Field Identification Procedures for Fine-Grained Soils¹

| Test | Test Procedures and Interpretation of Results |
|--------------------------|------------------------------------------------------------------------------------------------------------------------------------------------------------------------------------------------------------------------------------------------------------------------------------------------------------------------------------------------------------------------------------------------------------------------------------------------------------------------------------------------------------------------------------------------------------------------------------------------------------------------------------------------------------------------------------------------------------------------------------------------------------------------------------------------------------------------------------------------------------------------------------------------------------------------------------------------------------------------------------------------------------------------------------------------------|
| Dilatancy | Prepare a pat of moist soil with a volume equivalent to a 25-mm (1-in.) cube (Figure E-4). Add water, if necessary, to make the soil soft but not sticky, i.e., (reaction to the “sticky limit”). Place the pat of soil in the open palm of one hand and shake horizontally; strike vigorously against the other hand several times. If the reaction is positive, water appears on the surface of the pat; the consistency of the pat then becomes livery; and the surface of the pat becomes glossy (Figure E-5). Next, squeeze the sample between the fingers (Figure E-6). The water and gloss should disappear from the surface of the pat; the soil will stiffen and crack or crumble (Figure E-7). The rapidity of the appearance of water on the surface of the soil during shaking and its disappearance during squeezing help to identify the character of the fines in the soil. Very fine clean sands give the quickest and most distinct reaction, inorganic silts give a moderately quick reaction, and plastic clays have no reaction. |
| Dry strength | Mold a pat of soil to the consistency of putty. If the soil is too dry, add water; if it is too sticky, the specimen should be allowed to dry by evaporation. After the consistency of the pat is correct, allow the pat to dry (by oven, sun, or air). Test its strength by breaking and crumbling between the fingers (Figure E-8). The dry strength increases with increasing plasticity. High dry strength is characteristic of high plasticity clays. Silty sand and silts have only slight dry strengths, but can be distinguished by feel when powdered; fine sands feel gritty whereas silts feel smooth like flour. It should also be noted that shrinkage cracks may occur in high plasticity clays. Therefore, precautions should be taken to distinguish between a break which may occur along a shrinkage crack or a fresh break which is the true dry strength of the soil. |
| Toughness and plasticity | A specimen of soil which is about the size of a 25-mm (1-in.) cube should be molded to the consistency of putty; add water or allow to dry as necessary. At the proper moisture content, roll the soil by hand on a smooth surface or between the palms into a thread about 3-mm (1/8-in.) diam (Figure E-9). Fold the thread of soil and repeat the procedure a number of times. During this procedure, the water content of the soil is gradually reduced. As drying occurs, the soil begins to stiffen and finally loses its plasticity and crumbles at the plastic limit. After the thread has crumbled, the pieces should be lumped together and a kneading action should be applied until the lump crumbles. For higher clay contents, threads are stiffer and lumps are tougher at the plastic limit than for lower plasticity clays. |
| Dispersion test | A complementary test is the ribbon test. A roll of soil about 13-to 19-mm (1/2-to 3/4-in.) diam by 75 to 125 mm (3 to 5 in.) long should be prepared at a moisture content just below the “sticky limit”. Flatten the roll of soil to thickness of 3 to 6 mm (1/8 to 1/4 in.) between the thumb and forefinger (Figure E-10). For high plasticity clays, a ribbon 20 to 25 cm (8 to 10 in.) long can be formed; shorter lengths correspond to lower plasticity clays whereas a ribbon cannot be formed when using non-plastic soils. |
| Dispersion test | Place a few hundred grams of soil in a jar containing water. Shake the jar containing the mixture of soil and water and then allow the soil to settle. The rate of settling can be used to judge the (settlement predominate soil type(s) whereas the thicknesses of the various soils can be used to judge the gradation of the soil. Sands settle in 30 to 60 seconds, silts settle in 30 to 60 minutes, and clays may in water) remain in suspension overnight. The interface between fine sands and silts occurs where individual grains can not be discerned with the unaided eye. The cloudiness of the water indicates the relative clay content. |
| Bite test | Place a pinch of soil between the teeth and grind lightly. Fine sands grate harshly between the teeth; silts have a gritty feeling but do not stick to the teeth; clays tend to stick to the teeth, but do not have a gritty feeling. |
| Odor | Organic soils have a musty odor which diminishes upon exposure to air. The odor can be revived by heating a moist sample or by exposing a fresh sample. |
| Peat | Peat has a fibrous texture and is characterized by partially decayed sticks, leaves, grass, and other vegetation. A distinct organic odor is characteristic of peat. Its color generally ranges from dull brown to black. |
| Shine | A moist, highly plastic clay will shine when rubbed with a fingernail or pocketknife blade: a lean clay will have a dull surface. |
| Acid test | The presence of calcium carbonate in a soil can be determined by adding a few drops of dilute (3:1 ratio of water to acid) hydrochloric acid to the soil. The relative amount of calcium chloride in the soil can be determined by the effervescence (fizzing reaction) which occurs. Degrees of reaction range from none to strong. For some very dry non-calcareous soils, the illusion of effervescence as the acid is absorbed by the soil can be eliminated by moistening the soil before the acid is applied. |
| Slaking test | Certain shales and other soft “rocklike” materials disintegrate upon drying or soaking. The test is performed by placing the soil in the sun or oven to dry completely. After the sample has been dried, it should then be soaked in water. The degree of slaking should be reported. |

¹ These tests must be performed on the minus No. 40 sieve size (0.42 mm) particles, which is the division between medium and fine sand. For field classification purposes, screening is not intended; simply remove the coarse particles that interfere with the tests.

Table E-7
Strength or Consistency of Clays

| Descriptive Term | Blows ¹ per Foot ² | Unconfined Compressive Strength | | Field Test |
|------------------|------------------------------------------|---------------------------------|------------|----------------------------------------------------------------------------------------------------------------------------|
| | | kPa | (tsf) | |
| Very soft | < 2 | <25 | (< 0.25) | Core (height twice diameter) sags under its own weight while standing on end; squeezes between fingers when fist is closed |
| Soft | 2-4 | 25-50 | (0.25-0.5) | Easily molded by fingers |
| Medium | 4-8 | 50-100 | (0.5-1.0) | Molded by strong pressure of fingers |
| Firm | 8-15 | 100-190 | (1.0-2.0) | Imprinted very slightly by finger pressure |
| Very firm | 15-30 | 190-380 | (2.0-4.0) | Cannot be imprinted with finger pressure; can be penetrated with a pencil |
| Hard | > 30 | > 380 | (> 4.0) | Imprinted only slightly by pencil point |

¹ From SPT (Appendix B, Table B-1).

² 1 ft = 0.3048 m.

Table E-8
Moisture Content

| Condition | Estimated Water Content, percent | Example |
|---------------|----------------------------------|--------------------------------------------------------------------------------------|
| Dry | 0 - 10 | Absence of moisture; well below optimum water content for fine-grained soils |
| Moist | 10 - 30 | Fine-grained - damp, near optimum water content
Coarse-grained - no visible water |
| Wet | 30 - 70 | Fine-grained - well above optimum water content
Coarse-grained - visible water |
| Water bearing | ----- | Water drains freely, below water table |

Table E-9
Role of Color for Identification of Moist Fine-Grained Soils

General:

Detect different soil strata
Detect soil type based upon experience in local area
Colors become lighter as water content decreases

Soil Type:

Inorganic soils have clean, bright colors: light gray, olive green, brown, red, yellow, or white
Organic soils have dark or drab shades: dark gray, dark brown, or almost black

Presence of Chemicals:

Iron oxides: red, yellow, or yellowish brown
Silica, calcium carbonate, or aluminum compounds: white or pinkish

Drainage Conditions:

Poor: grayish blue and gray or yellow mottled colors

Table E-10
Terms for Describing Mass Structure of Soils

| Descriptive Term | Definition |
|------------------|------------------------------------------------------------------------------------------|
| Homogeneous | Uniform properties |
| Heterogeneous | Mixtures of soil types not in layers or lenses |
| Stratified | Alternate layers of different soils or colors |
| Laminated | Repeating alternate layers of different soils or colors 3 to 6 mm (1/8 to 1/4 in.) thick |
| Banded | Alternate layers in residual soils |
| Lensed | Inclusions of small pockets of different soils |

Table E-11
Terms for Describing Mass Defects in Soil Structure

| Descriptive Term | Definition |
|---------------------|----------------------------------------------------------------------------------------|
| Slickensides | Fracture of failure planes (polished surfaces) seen in stiff clays |
| Root holes | Holes remaining after roots have decayed |
| Fissures | Cracks from shrinkage, frost, etc.; specimen breaks along a definite plane of fracture |
| Weathered, oxidized | Irregular discolorations |
| Concretions | Accumulations of carbonates or iron compounds |
| Blocky | Cohesive soil broken into small angular lumps which resist further breakdown |

Table E-12
Commonly Used Descriptive Soil Names (Continued)

| Common Name | Description |
|-------------------------------|---------------------------------------------------------------------------------------------------------------------------------------------------------------------------------------------------------------------------------------------------------------------------------------|
| Adobe | Soils such as calcareous silts and sandy-silty clays which are found in semiarid regions of southwestern United States and North Africa. |
| Alluvium | Deposits of mud, silt, and other material commonly found on the flat lands along the lower courses of streams. |
| Argillaceous | Soils which abound in clays or clay-like materials. |
| Bentonite | A clay of high plasticity formed by the decomposition of volcanic ash. |
| Boulder clay (L) ¹ | A name, used in Canada and England, for glacial till. |
| Buckshot (L) | Clays of southern and southwestern United States which crack into small, hard lumps of more or less uniform size upon drying. |
| Bull's liver (L) | The term name used in some sections of the United States to describe an inorganic silt of slight plasticity, which, when saturated, quakes like jelly from vibration or shock. |
| Calcareous | Soils which contain an appreciable amount of calcium carbonate, usually from limestone. |
| Caliche | The term which describes deposits of silt, clay, and sand cemented by calcium carbonate deposited by evaporation of groundwater; this material is found in France, North Africa, and southwestern United States. |
| Coquina (L) | Marine shells which are held together by a small amount of calcium carbonate to form a fairly hard rock. |
| Coral | Calcareous, rock-like material formed by secretions of corals and coralline algae. |
| Diatomaceous earth | A white or light gray, extremely porous, friable, siliceous material derived chiefly from diatom remains. |
| Dirty sand (L) | A slightly silty or clayey sand. |
| Disintegrated granite | Granular soil derived from decomposition and weathering of granite rock. |
| Fat clay (L) | Fine colloidal clay of high plasticity. |
| Fuller's earth | Highly plastic white to brown clays of sedimentary origin which are used commercially to absorb fats and dyes. |
| Gumbo (L) | Highly plastic silty and clayey soils which become impervious, sticky, and soapy or waxy when saturated. |
| Hardpan | A general term used to describe a hard, cemented soil layer which does not soften when wet. |
| Lateritic soils | Residual soils, usually red in color, which are found in tropical regions. In their natural state, these soils have a granular structure with low plasticity and exhibit good drainage characteristics; when remolded in the presence of water, they often become plastic and clayey. |
| Lean clay | Silty clays and clayey silts of low to medium plasticity. |

¹ (L) refers to a name which is used in local areas, only.

Table E-12 (Concluded)

| Common Name | Description |
|--------------------|--------------------------------------------------------------------------------------------------------------------------------------------------------------------------------|
| Limerock (L) | A soft, friable, creamy white limestone found in the southeastern United States; it consists of marine remains which have disintegrated by weathering. |
| Loam | An agricultural term used to describe sandy-silty topsoils which contain a trace of clay, are easily worked, and are productive of plant life. |
| Loess | A silty soil of eolian origin characterized by a loose, porous structure, and a natural vertical slope; it covers extensive areas in North America, Europe, and Asia. |
| Marl | A soft, calcareous deposit mixed with clays, silts, and sands, and often contains shells or organic remains; it is common in the Gulf Coast area of the United States. |
| Micaceous soils | Soil which contains a sufficient amount of mica to give it distinctive appearance and characteristics. |
| Muck (mud) | Very soft, slimy silt which is found on lake or river bottoms. |
| Muskeg | Peat deposits found in northwestern Canada and Alaska. |
| Peat | Fibrous, partially decayed organic matter or a soil which contains a large proportion of such materials; it is extremely compressible and is found in many areas of the world. |
| Red dog (L) | The residue from burned coal dumps. |
| Rock flour | A low plasticity, sedimentary soil composed of silt-sized particles which may become quick at high moisture contents. |
| Shale | A thinly laminated rock-like material which has resulted from consolidation of clay under extreme pressure; some shales revert to clay on exposure to air and moisture. |
| Talus | A fan-shaped accumulation of fragments of rock that have fallen near the base of a cliff or steep mountainside as a result of weathering. |
| Topsoil | The top few inches of soil which contains considerable organic matter and is productive of plant life. |
| Tufa | A loose, porous deposit of calcium carbonate which usually contains organic remains. |
| Tuff | Stratified, compacted deposits of fine materials, such as cemented dust and cinders, ejected from volcanoes. Tuffs are prevalent in the Mediterranean area. |
| Varved clay | A sedimentary deposit which consists of alternate thin (less than 13 mm) layers of silt and clay. |
| Volcanic ash | Uncemented volcanic debris which consists of particles less than 3 mm diameter; upon weathering, a clay of high compressibility is formed. |

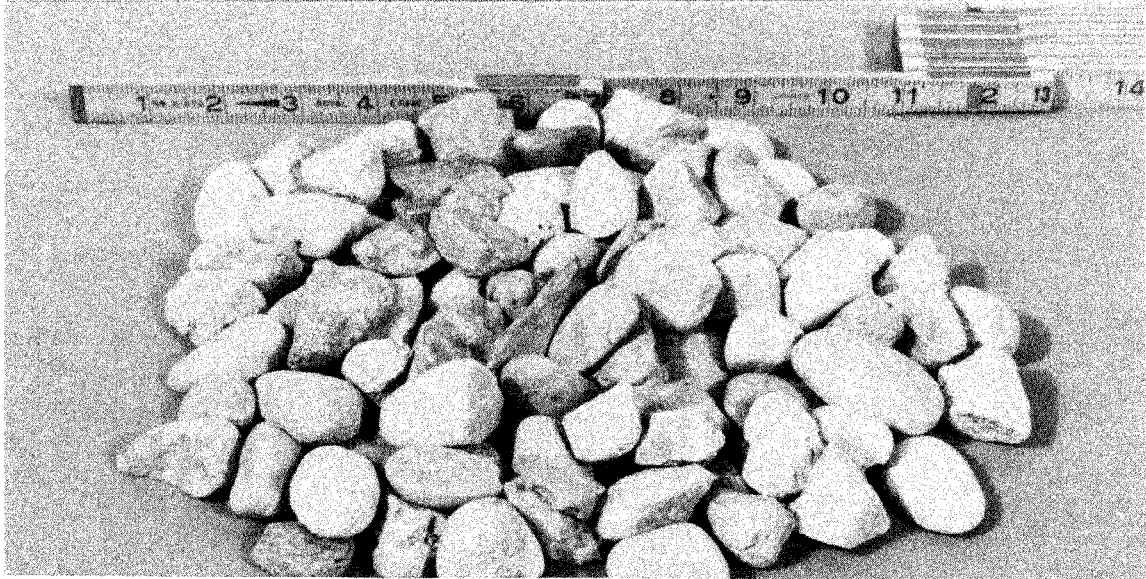

a. Coarse gravel

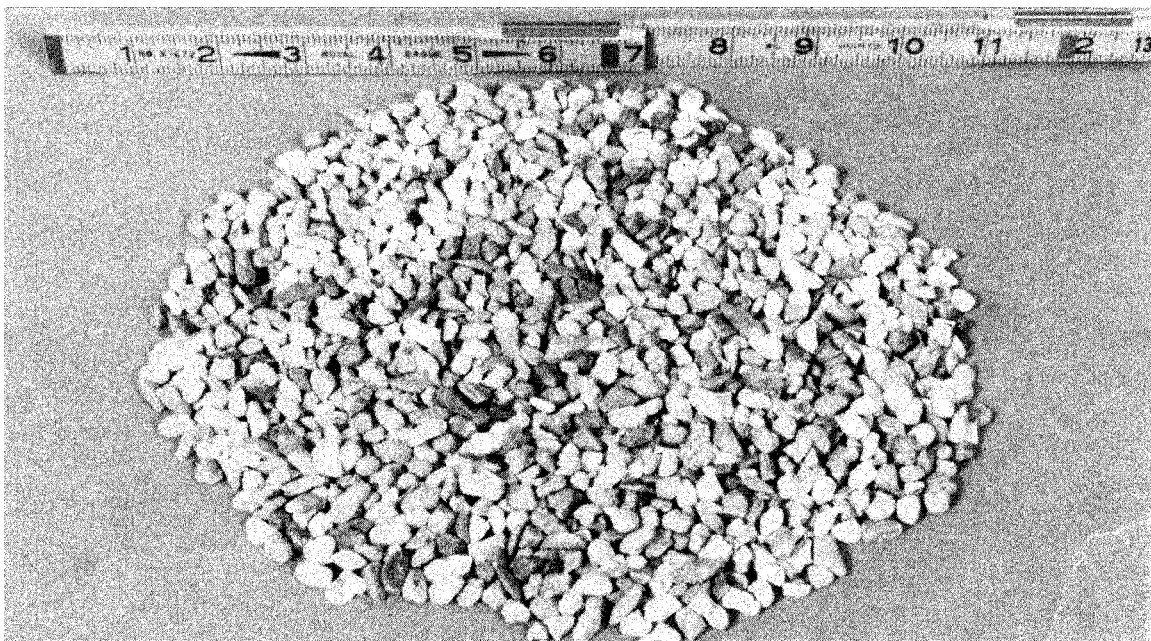

b. Fine gravel

Figure E-1. Photographs of several soils to aid in selecting terms for describing the grain size of soil (Sheet 1 of 3)

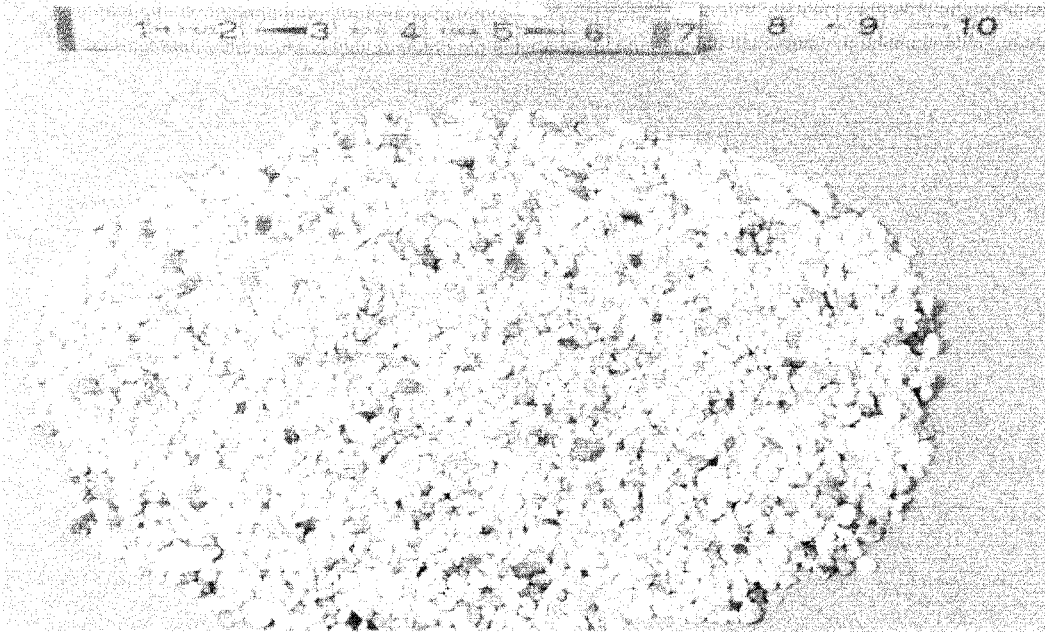

c. Coarse sand

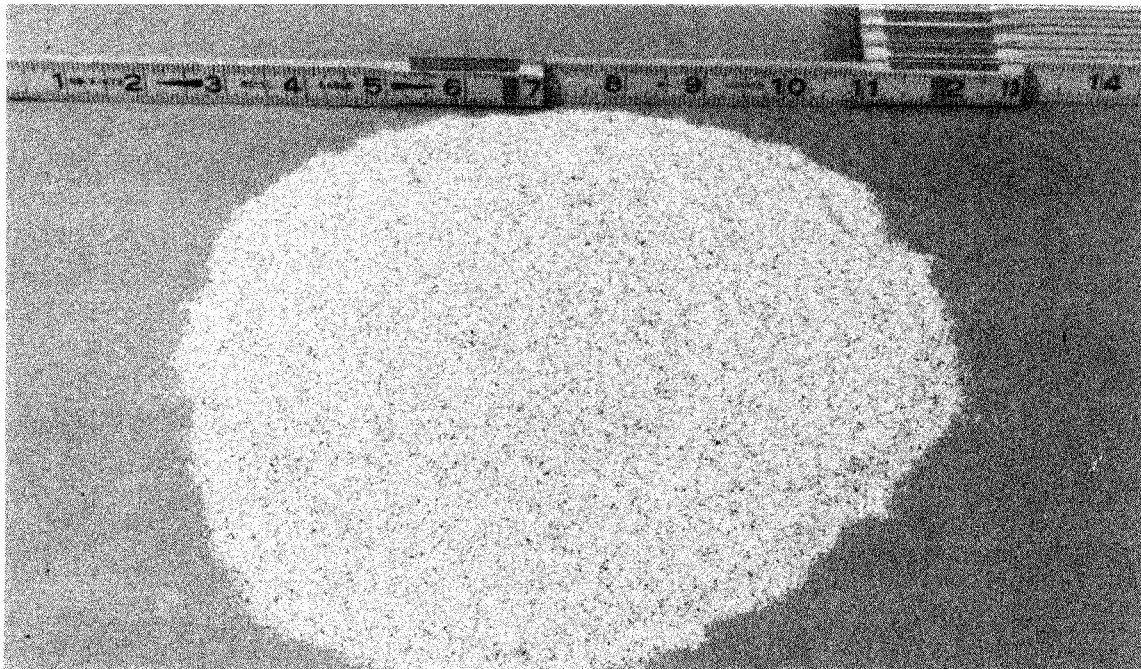

d. Fine sand

Figure E-1. (Sheet 2 of 3)

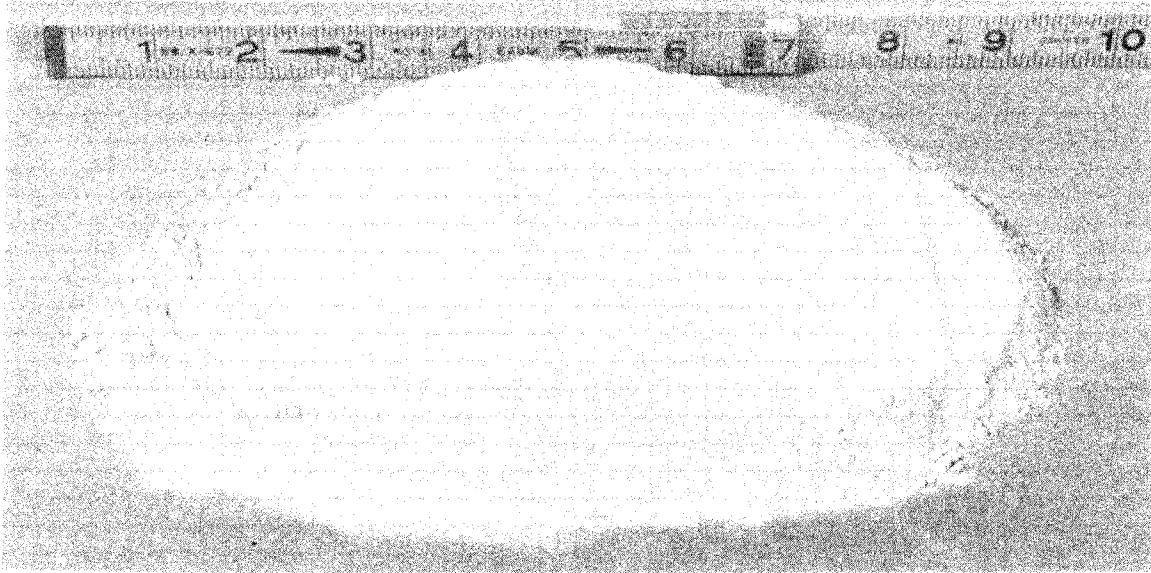

e. Silt or clay

Figure E-2. Sheet 2 of 3)

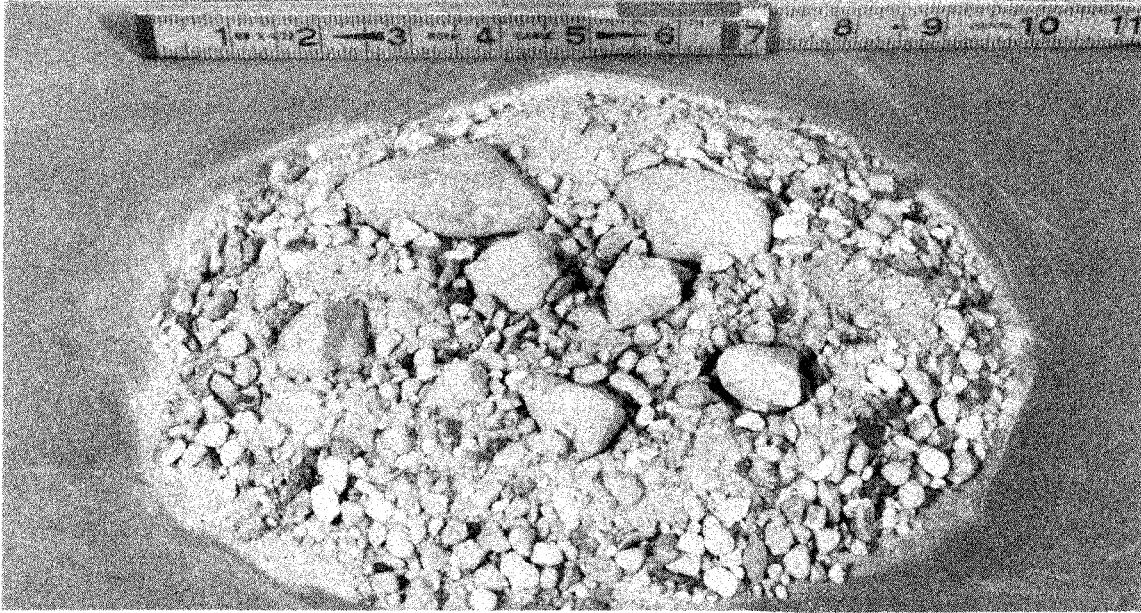

a. Well graded

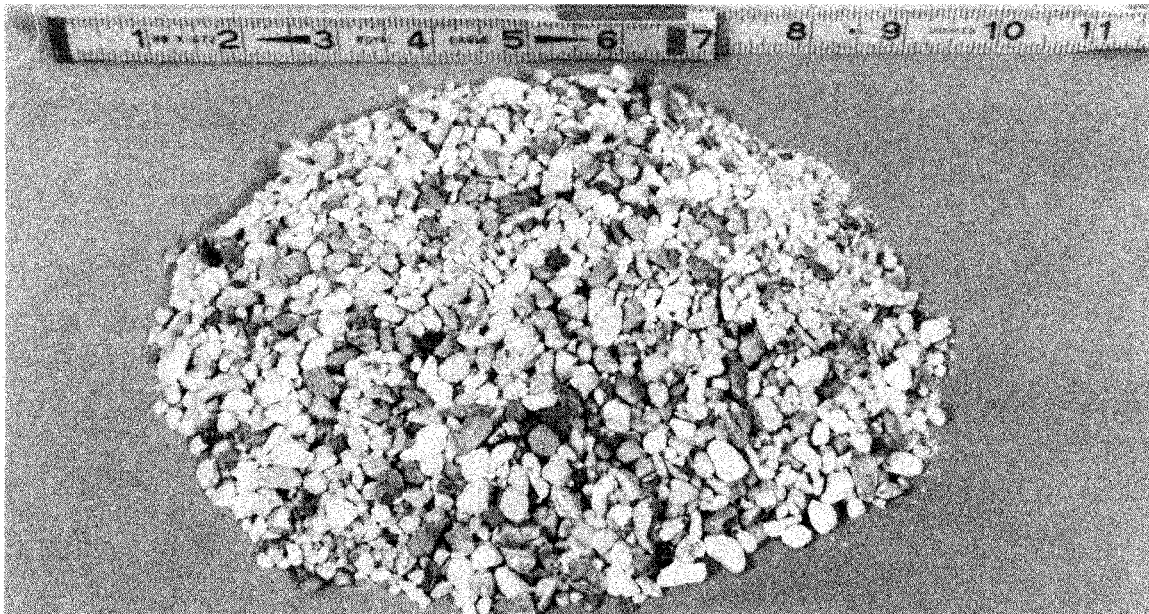

b. Uniformly or poorly graded

Figure E-2. Photographs of several soils to aid in selecting terms for describing the gradations of coarse-grained soils (Continued)

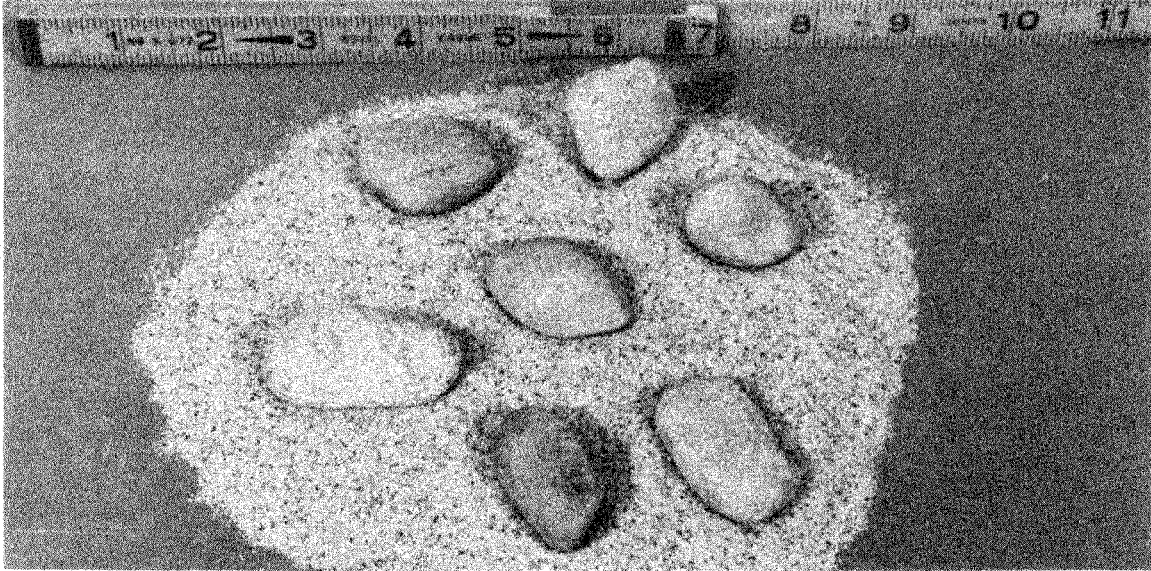

c. Gap graded

Figure E-2. (Concluded)



a. Rounded



b. Subrounded

Figure E-3. Photographs of several soils to aid in selecting terms for describing the grain shape of coarse-grained soils (Continued)

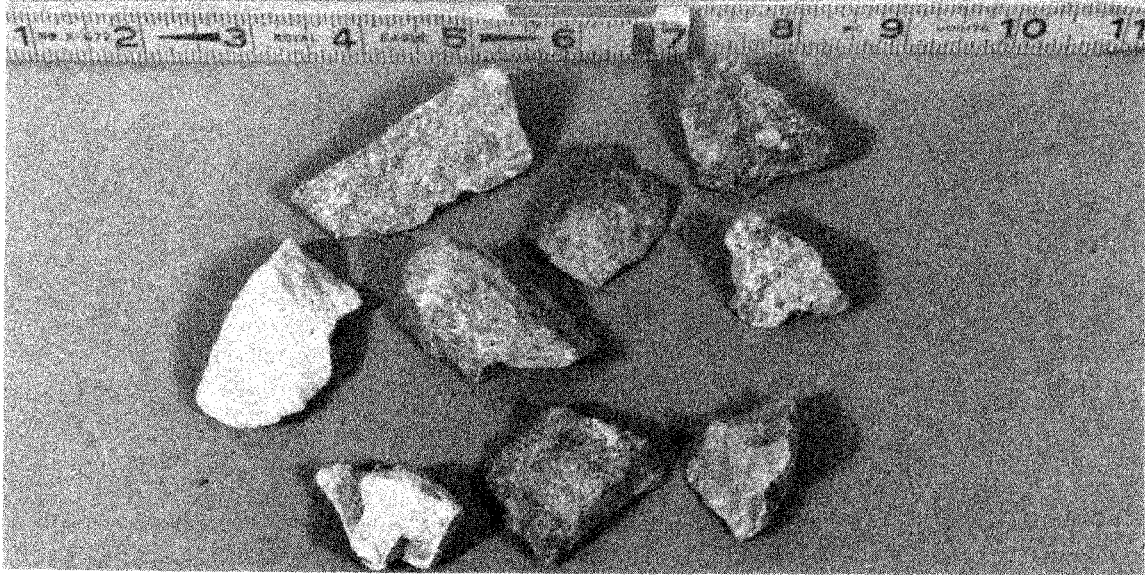

c. Subangular

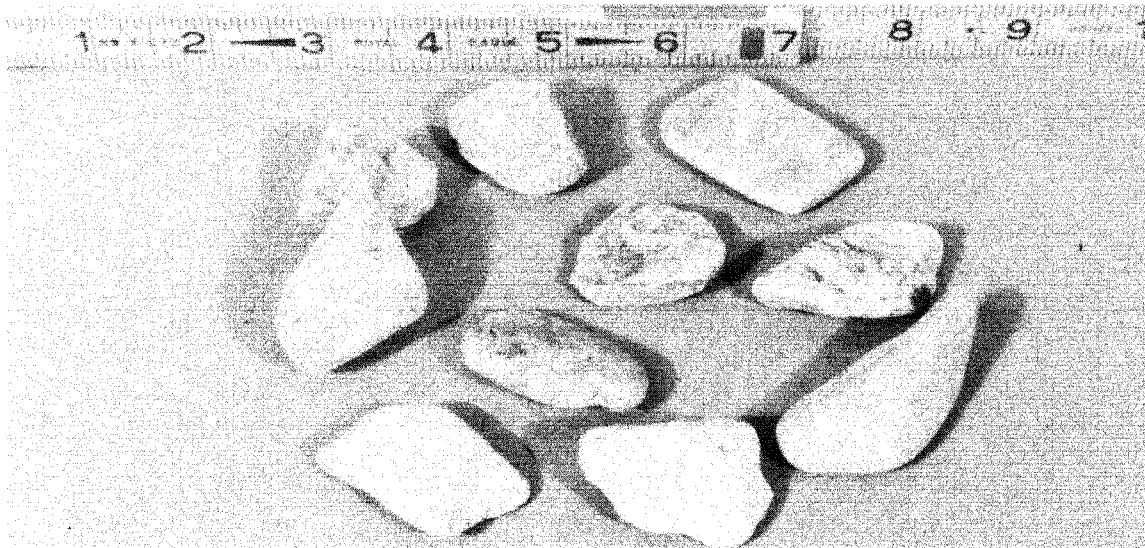

d. Angular

Figure E-3. (Concluded)

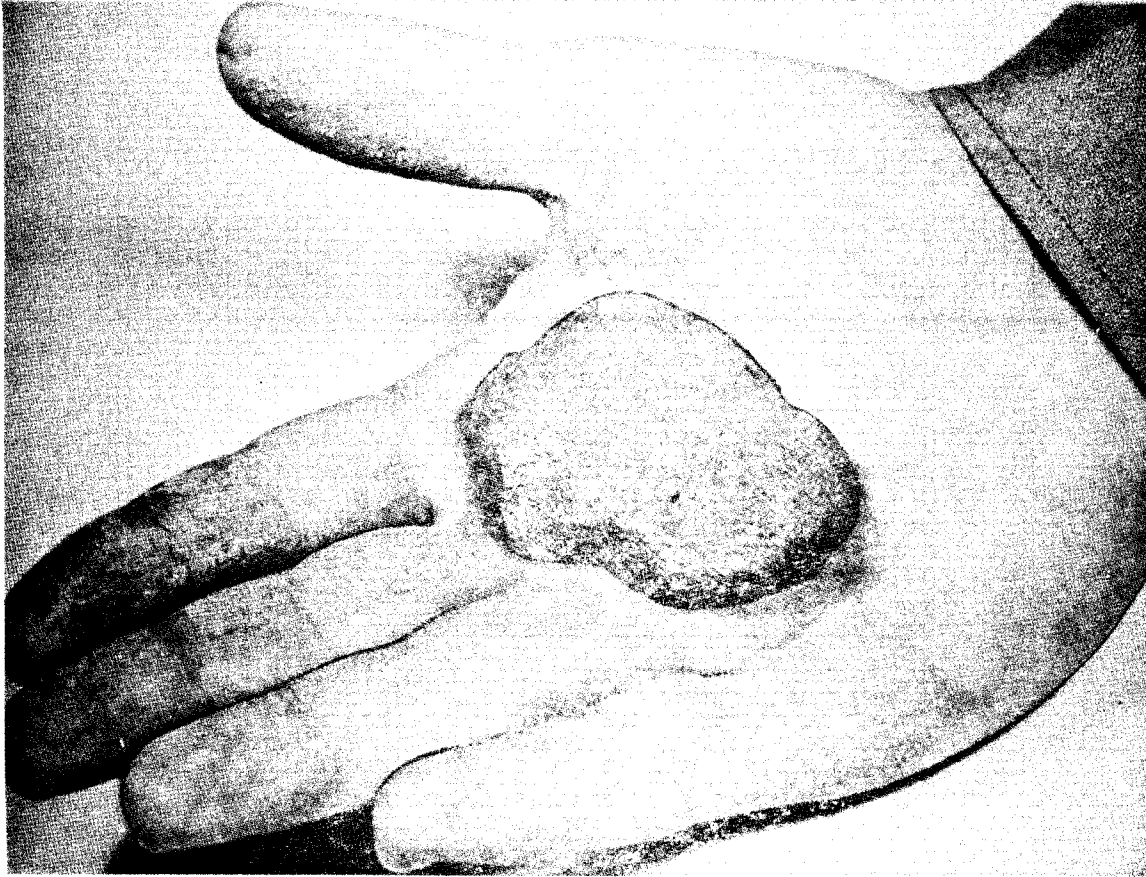

Figure E-4. Appearance of sample of moist, fine-grained soil prior to conducting the dilatancy test

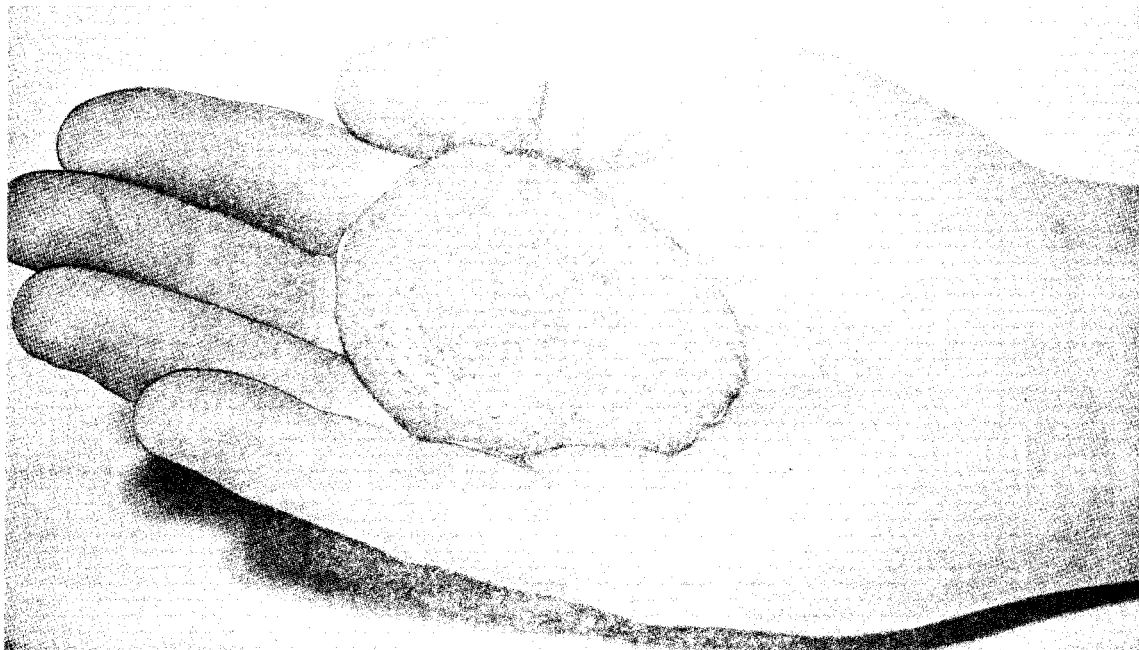

Figure E-5. Lively appearance of a sample of moist, fine-grained soil which occurred as a result of shaking during the dilatancy test



Figure E-6. Photograph of a sample of a moist, fine-grained soil being squeezed during the dilatancy test



Figure E-7. A sample of a moist, fine-grained soil cracking and crumbling during the dilatancy test

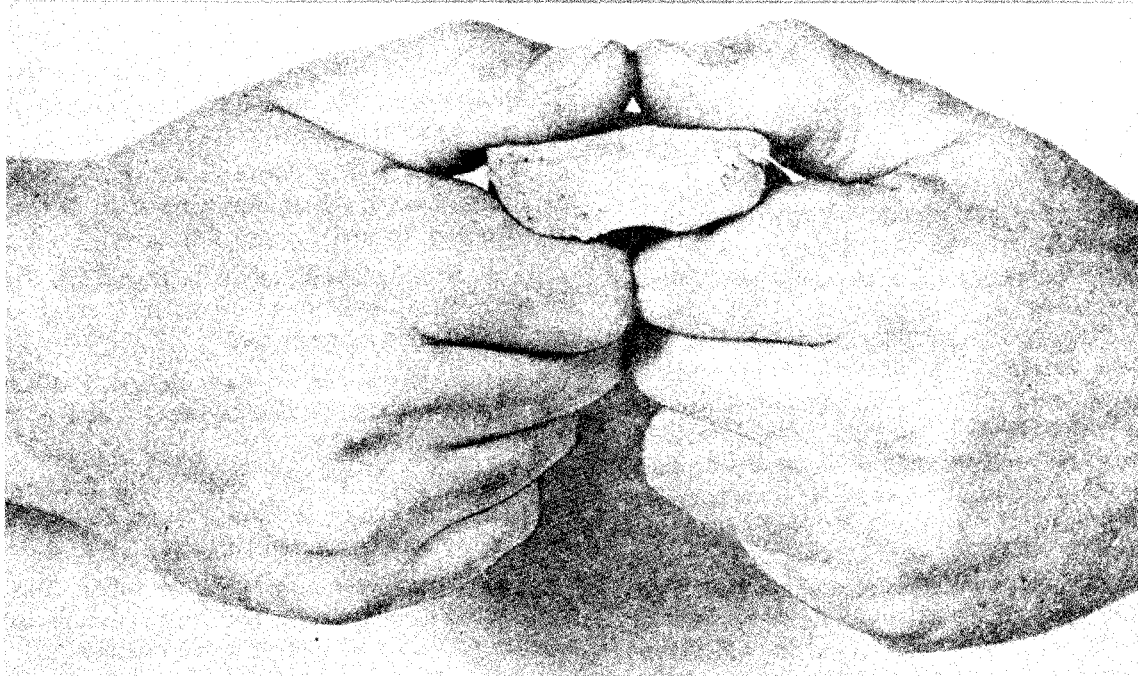

Figure E-8. A sample of a dry, fine-grained soil being broken to determine its dry strength

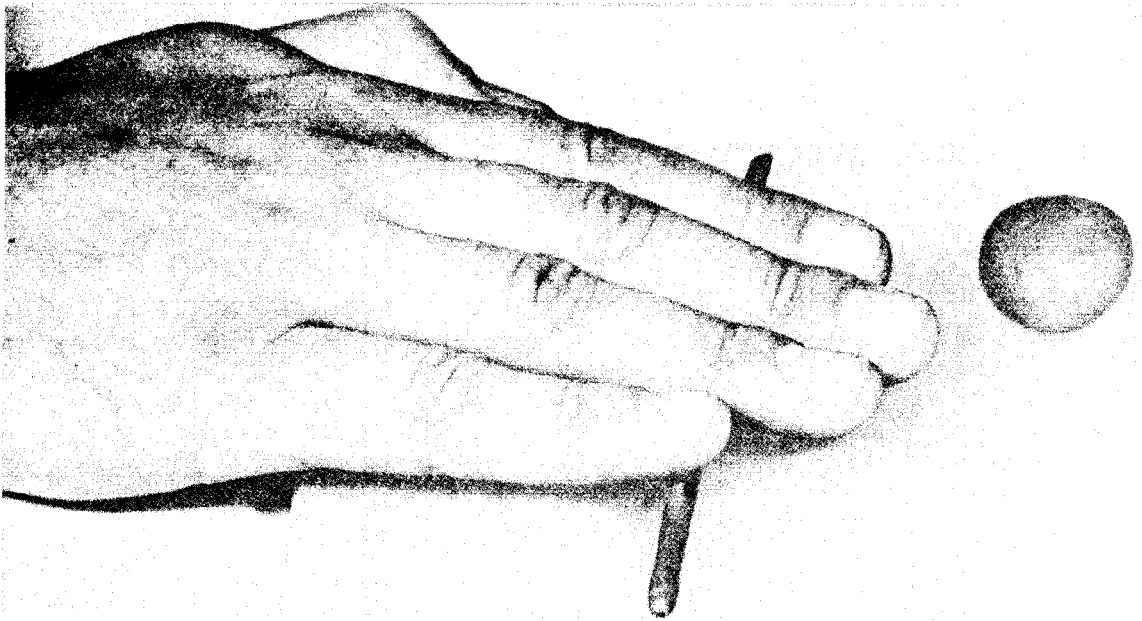

Figure E-9. A sample of a moist, fine-grained soil being rolled to a 3-mm- (1/8-in.-) diam thread to determine its toughness and plasticity

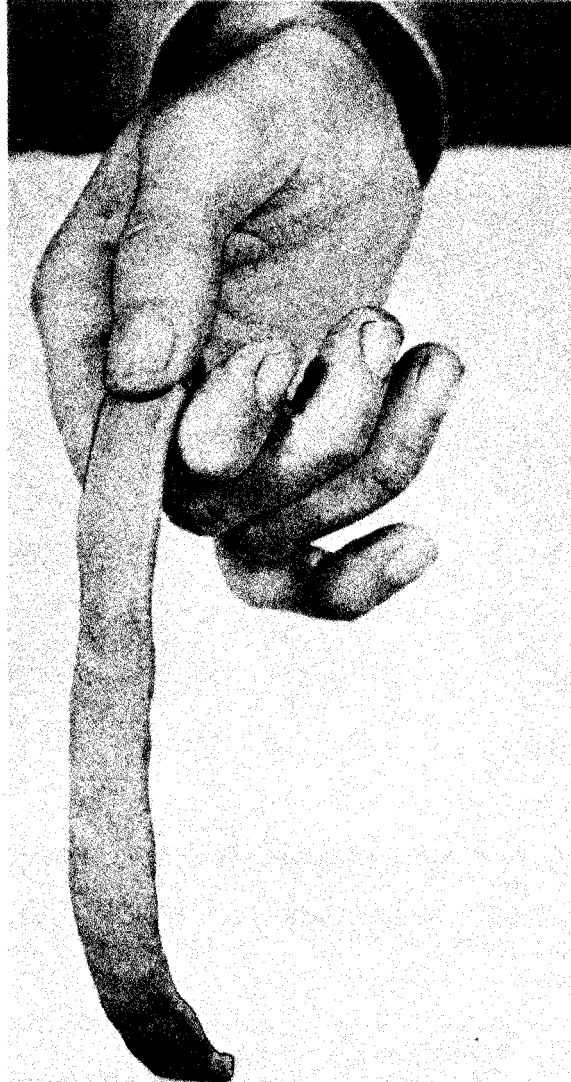

Figure E-10. Photograph of a sample of a moist, fine-grained soil being flattened to a ribbon about 3 to 6 mm (1/8 to 1/4 in.) thick to determine its toughness and plasticity

Appendix F Soil Sampling

*In an effort to consolidate Corps guidance documents, Engineer Manual EM 1110-1-1906, Soil Sampling, 30 September 1996, has been modified and is included as **Appendix F** of this manual.*

Appendix G (*Appendix B of EM 1110-1-1906*) Penetration Resistance Test and Sampling with a Split-Barrel Sampler

G-1. Introduction

The method of sampling soil described herein consists of driving a split-barrel sampler to obtain a representative, disturbed sample and to simultaneously obtain a measure of the resistance of the subsoil to penetration of a standard sampler. The resistance to penetration is obtained by counting the number of blows required to drive a steel tube of specified dimensions into the subsoil a specified distance using a hammer of a specified weight (mass). This test is commonly referred to as the Standard Penetration Test (SPT). The soil sample which is obtained as a part of the test can be used for water content determination, soil-type identification purposes, and laboratory tests in which the degree of disturbance of the sample does not adversely affect the results. See Chapters 7 and 8 for additional information on sampling with open tube samplers.

The results of the SPT have been used extensively in many geotechnical exploration projects. The SPT blowcount, N , is a measure or index of the in-place firmness or denseness of the foundation material. Many local correlations as well as widely published correlations which relate SPT blowcount and the engineering behavior of earthworks and foundations are available. Because the SPT is considered to be an index test, blowcount data should be interpreted by experienced engineers only.

In general, the SPT blowcount data are applicable to fairly clean medium-to-coarse sands and fine gravels at various water contents and to saturated or nearly saturated cohesive soils. When cohesive soils are not saturated, the penetration resistance may be misleading of the behavior of the material as a foundation soil. Likewise, the engineering behavior of saturated or nearly saturated silty sands may be underestimated by the penetration resistance test.

The relative firmness or consistency of cohesive soils or density of cohesionless soils can be estimated from the blowcount data which is presented in Table G-1. The bearing capacity of cohesionless and cohesive soils can also be estimated from the SPT blowcount data. For blowcounts in excess of 25 blows, the bearing capacity is excellent. For blowcounts less than 10 blows, the bearing capacity is poor. Hard, saturated cohesive soils and dense to very dense cohesionless soils will support moderately heavy-to heavy loads, whereas very firm cohesive soils and medium dense- to dense cohesionless soils are adequate for most lighter loads.

G-2. Equipment and Terminology

A qualitative measurement of the dynamic penetration resistance of soil is obtained by driving a split-spoon sampler. To be meaningful, the value of penetration resistance must be obtained with standardized equipment and procedures. The following paragraphs describe the standard equipment which is required for the SPT and the associated terminology. The description of the equipment and the terminology are generally compatible with ASTM D 1586-84, "Standard Method for Penetration Test and Split-Barrel Sampling of Soils" (ASTM 1993)¹ and the SPT procedure recommended by the International Society for Soil Mechanics and Foundation Engineering, "Standard Penetration Test (SPT): International Reference Test Procedure" (Decourt et al. 1988).

a. Incremental blowcount. \bar{N} is the number of blows for each 150-mm (6-in.) interval of sampler penetration for the 0- to 150-mm (0- to 6-in.) interval, for the 150- to 300-mm (6- to 12-in.) interval, and for the 300- to 450-mm (12- to 18-in.) interval.

b. Blowcount. N is the blowcount representation, in blows per foot, of the penetration resistance of the soil. The SPT N -value equals the sum of the blows of the hammer which are required to drive a standard sampler for the depth interval from 150 to 300 mm (6 to 12 in.) plus the depth interval from 300 to 450 mm (12 to 18 in.).

c. Drive weight assembly. The drive weight assembly consists of a hammer, a hammer fall guide, the anvil, and any hammer-drop system.

(1) *Hammer.* The hammer is that portion of the drive weight assembly consisting of a 63.5 ± 1 kg (140 ± 2 lb) impact weight which is successively lifted and dropped to provide the energy that accomplishes the penetration and sampling. A pinweight hammer, a donut hammer, and a safety hammer have been used as the drive weight. A schematic diagram of each is given in Figure G-1. The donut hammer and the safety hammer are commercially available.

(2) *Hammer fall guide.* The hammer fall guide is that part of the drive weight assembly which is used to guide the unimpeded fall of 760 ± 25 mm (30 ± 1.0 in.) of the hammer. Although it is desirable that the energy of the falling weight is not reduced by friction between the hammer and the hammer guide, the energy from the sliding hammer may be transmitted to the drill string at various efficiencies, depending upon the manufacturer's design. Because of this source of error, the type of equipment used should be recorded.

(3) *Anvil.* The anvil is that portion of the drive weight assembly through which the hammer energy is transmitted to the drill rods as it is impacted by the falling hammer. The hammer and anvil should be designed for steel on steel contact when the hammer is dropped.

(4) *Hammer drop system.* The hammer drop system is that portion of the drive weight assembly by which the operator accomplishes the lifting and dropping of the hammer to produce the blow. The cathead and rope system, trip system, or the semiautomatic or automatic hammer drop system may be used provided that the lifting apparatus will not cause penetration of the sampler into the formation while reengaging and lifting the hammer. Hammers used with the cathead and rope method should have an unimpeded overlift range of at least 100 mm (4 in.). A schematic diagram of an automatic trip for a donut hammer is presented in Figure G-2. For safety reasons, the use of a hammer assembly with an internal anvil (safety hammer) is encouraged.

(a) *Cathead.* The cathead is the rotating drum in the cathead and rope lift system. The operator successively tightens and loosens the rope turns around the drum to lift and drop the hammer.

(b) *Number of rope turns.* The number of turns of the rope can be determined as the total contact angle between the rope and the cathead divided by 360 deg. The contact angle begins at a point where the rope from the sheave at the top of the derrick makes contact with the cathead and ends at a point where the rope leading from the cathead to the operator's hands ceases to make contact with the cathead.

Two turns of the rope on the cathead is recommended. However, the actual number of turns of rope on the cathead is approximately 2-1/4 turns for clockwise rotation of the cathead or 1-3/4 turns for

counterclockwise rotation of the cathead. Figure G-3 is a sketch of the rope wrapped on the cathead which illustrates the number of turns of the rope.

d. Drilling equipment. Drilling equipment is used to provide a suitably clean open hole in which the sampler can be inserted. The diameter of the borehole should be greater than 56 mm (2.2 in.) and less than 162 mm (6.5 in.). The selection of appropriate drilling equipment and performing the drilling operations using accepted drilling procedures help to ensure that the penetration test is conducted on undisturbed soil.

(1) *Drill rods.* The drill rods are used to transmit the downward force and torque from the drill rig to the drill bit for drilling the borehole.

(2) *Drag, chopping, or fishtail bits.* These drill bits may be used in conjunction with open-hole rotary drilling or casing-advancement drilling methods. To avoid disturbance to the underlying soil, drilling fluid must be discharged through ports on the side of the bits. Bottom discharge of the drilling fluid is not permitted.

(3) *Roller cone bits.* Roller cone bits may be used in conjunction with open-hole rotary drilling or casing- advancement drilling methods. The drilling fluid must be deflected to avoid disturbance to the underlying soil.

(4) *Hollow-stem continuous-flight augers.* Hollow-stem augers may be used with or without a center bit assembly to drill the borehole.

(5) *Solid-stem continuous-flight augers, bucket augers, and hand augers.* Solid-stem augers, bucket augers, or hand-held augers may be used if the soil on the walls of the borehole does not cave onto the sampler or sampling rods during sampling operations.

e. Sampling equipment. Sampling equipment is used to obtain a soil sample in conjunction with the SPT.

(1) *Sampling rods.* Sampling rods, which are considered to be synonymous with drill rods, are flush joint steel drilling rods that connect the drive weight assembly to the split-barrel sampler. The sampling rods should have a stiffness (moment of inertia) equal to or greater than the stiffness of an "A" rod; an "A" rod is a steel rod which has an OD of 41 mm (1-5/8 in.) and an ID of 29 mm (1-1/8 in.). Research has indicated that drill rods with stiffnesses ranging from "A" to "N" rod sizes will usually have a negligible effect on the SPT blowcount, N, values to depths of at least 30 m (100 ft). However, "N" rods which are stiffer than "A" rods are recommended for holes deeper than 15 m (50 ft).

(2) *Split-barrel sampler.* The split-barrel sampler, which is frequently called a split-spoon sampler, consists of a sampler head, a split-barrel sampling tube, and a driving shoe. A schematic drawing of a split-barrel sampler is shown in Figure G-4. Before the sampler is used, all components should be clean and free of nicks and scars made from tools and rocks. Individual components should be replaced or repaired if they become dented or distorted.

(a) *Sampler head.* The sampler head contains a number of vents of sufficient size which will permit unimpeded flow of air or water from the tube upon entry of the sample. These vents should be equipped with nonreturn valves which will provide a watertight seal when the sampler is withdrawn from the

borehole. For a typical, commercially available split-spoon sampler, the sampler head contains four vent holes. Each vent hole is usually 13 mm (1/2-in.) diameter.

(b) *Split-barrel sampling tube.* The split-barrel sampling tube is made of hardened steel with smooth internal and external surfaces. Its dimensions are 51-mm (2-in.) OD by 35-mm (1-3/8-in.) ID. The minimum length of the tube is 457 mm (18 in.). It should be noted that a split-barrel sampling tube with an ID of 38 mm (1-1/2 in.) may be used provided that the tube contains a liner of 16-gauge (1.5-mm) wall thickness.

(c) *Driving shoe.* The driving shoe is heat-treated, case-hardened steel. It has an OD of 51 mm (2 in.) and an ID of 35 mm (1-3/8 in.). Its length is 76 mm (3 in.). The outside of the bottom 19 mm (3/4 in.) of the driving shoe should be tapered uniformly inward to the internal bore to form a the cutting edge.

(3) *Liners.* Liners can be used provided that a constant ID of 35 mm (1-3/8 in.) is maintained. The use of liners should be noted on the boring log or penetration record.

(4) *Sample retainers.* A variety of sample retainers may be used to prevent sample loss during the withdrawal of the sampler from the borehole. The type of sample retainer should be noted on the penetration record.

G-3. Advancing the Borehole

The borehole may be advanced using equipment and procedures that provide a suitably clean stable hole and assure that the SPT can be performed on essentially undisturbed soil. Methods of advancing the borehole which have been proven to be acceptable include wireline or open-hole rotary drilling, continuous-flight hollow-stem or solid-stem augering, and wash boring methods provided that bottom discharge bits are not used. Methods which produce unacceptable borings include jetting through an open-tube sampler followed by sampling when the desired depth is reached, using continuous-flight solid-stem augers in cohesionless deposits below the water table, drilling into a confined cohesionless stratum that is under artesian pressure, or advancing the borehole solely by means of previous sampling with the SPT sampler. The use of a bottom discharge bit is strictly prohibited.

The borehole can be advanced incrementally, alternating with testing and sampling operations. Continuous sampling of the substrata may be conducted, although this could affect the N-values; typical testing and sampling intervals are 0.6 to 1.5 m (2 to 5 ft) in homogeneous strata. Additional tests should be conducted at every change of strata. Boreholes can be stabilized using procedures which were outlined in paragraph 6-2 for undisturbed sampling operations. If drilling mud is used, the drilling fluid level in the borehole should be maintained at or above the groundwater level at all times. Drilling and sampling tools should be withdrawn slowly to prevent disturbance of the soil on the bottom and the walls of the borehole. If casing is used, the casing should not be advanced below the top of the stratum to be sampled.

The diameter of the borehole should be greater than 56 mm (2.2 in.) and less than 162 mm (6.5 in.). A smaller diameter hole may tend to close slightly and bind the drill rods, whereas a larger diameter hole may significantly alter the stresses at the bottom of the borehole. A large-diameter borehole may also allow excessive bending of the drill rods, especially for long sections of drill rod. These conditions could result in erroneous penetration resistances.

G-4. Sampling and Testing Procedure

After the boring has been advanced to the desired sampling depth or elevation and excessive cuttings have been carefully removed from the bottom of the borehole, the split-spoon sampling apparatus may be assembled and lowered into the borehole. The recommended procedures for conducting the SPT and obtaining a representative sample of soil are presented below.

As the drilling rods are connected to lower the sampler to the bottom of the borehole, inspect each sampling rod to ensure that it is straight. If the relative deflection of a particular rod is greater than approximately 1:1000, it should not be used. Precaution should be taken to ensure that each rod joint is securely tightened. When the sampling apparatus has been lowered to the bottom of the borehole, secure the drill rods and sampler by the chuck on the drill rig to prevent disturbance of the soil at the bottom of the borehole as the hammer drive weight assembly is attached to the sampling rods. Attach the hammer assembly to the top of the drill rods and carefully lower the sampler onto the soil at the bottom of the borehole. Do not allow sampler to drop onto the soil to be sampled. Rest the deadweight of the sampler, sampling rods, and hammer drive weight assembly on the bottom of the boring.

a. Seating the split-barrel sampler. Compare the depth of the bottom of the borehole to the depth of the bottom of the sampler. If the sampling spoon advances below the bottom of the borehole under the static weight of the drill rods plus the weight of the hammer, measure the penetration of the sampler into the soil and note this information on the boring log. After the initial penetration caused by the deadweight of the SPT sampling system has occurred, apply one blow of the hammer to seat the sampler. Note this depth on the boring log and drive the sampler as described in paragraph G-4b. If the static penetration exceeds 450 mm (18 in.), stop the test and record the blowcount as zero. Remove the rods and sampler from the boring. Advance the borehole to the next sampling depth, remove the cuttings, and lower the sampler to the bottom of the borehole to begin the next drive.

If the depth of the sampling spoon is less than the depth to which the borehole was advanced, cuttings may have settled to the bottom of the hole or the walls of the borehole may have sloughed. Note the depths of the bottom of the borehole and the sampler on the boring log. If the difference of the depths is less than 76 mm (3 in.), which is the length of the driving shoe, apply one hammer blow to the sampler. Again, compare the depths of the bottom of the borehole to the bottom of the sampler. If the sampler is seated in virgin material at the bottom of the borehole, note the depth on the boring log. If the sampling spoon is not seated in virgin material, apply an additional blow with the hammer. Again, compare the depths of the bottom of the cleaned borehole to the bottom of the sampler and note these data on the boring log. Repeat the procedure until the sampling spoon is seated in virgin material. When the bottom of the sampling spoon has been embedded in virgin material, apply one blow to seat the sampler; record this depth on the boring log, and then drive the sampler according to the procedures which are described in paragraph G-4b.

If the difference of the depths of the bottom of the borehole and the bottom of the sampler is greater than the length of the driving shoe, remove the sampler from the borehole. Clean the cuttings and/or slough material from the hole. Record this operation on the boring log. When the cleaning operation has been completed, lower the sampler into the borehole and compare the depth of the bottom of the sampler to the depth at the bottom of the hole. If the difference of the depths is less than 76 mm (3 in.), seat the sampler as described in the preceding paragraph. If the difference of the depths is greater than 76 mm (3 in.), remove the sampler from the boring and repeat the cleaning procedure.

After the split-barrel sampler has been seated in virgin material, mark the rods in three successive 150-mm (6-in.) increments so that the advance of the sampler under the impact of the hammer can be easily observed for each 150-mm (6-in.) increment of penetration. It should be noted that although the penetration of the sampler through the cuttings which have settled to the bottom of the borehole is not considered to be part of the penetration resistance test, the penetration of the sampler through this material must be considered as the total penetration or drive of the sampler. Care is required to ensure that the sampler is not overdriven. Overdriving of the sampler, which occurs when the total penetration of the sampler exceeds the total inside open length of the sampler, will result in erroneous penetration resistance data.

b. Driving the sampler. To drive the sampler, the 63.5-kg (140-lb) hammer is raised 0.76 m (30 in.) above the upper face of the drivehead assembly. The hammer is then allowed to fall freely and strike the face of the drivehead assembly. The procedure is repeated to drive the sampler into the soil.

Methods for raising and dropping the hammer include the automatic, semiautomatic, and trip-hammer drop systems. The drop of the hammer should be checked to ensure that the hammer falls exactly 0.76 m (30 in.) unimpeded. The desired rate of application of hammer blows is 30 per minute (min). It is assumed for most soils that this rate of application will permit the conditions at the sampling spoon to equilibrate between successive blows of the hammer.

If the cathead and rope method of raising the hammer is employed, a number of conditions should be considered and addressed. For each hammer blow, a 0.76-m (30-in.) lift and drop should be used by the operator. Marks may be placed on the guide rod at 0.74 and 0.76 m (29 and 30 in.) to aid the operator in determining the point at which the hammer has been raised exactly 0.76 m (30 in.). The operation should be performed rhythmically without holding the rope at the top of the stroke. The desired rate of application of hammer blows is 30 per min. An excessive rate of application of blows could prevent equilibrium between blows or could result in a nonstandard drop distance. Two turns of a relatively dry, clean, and unfrayed rope should be used on the cathead. The cathead should be operated at a minimum speed of 100 revolutions per minute (rpm). It must be essentially free of rust, oil, or grease and have a diameter in the range of 150 to 250 mm (6 to 10 in.). These values should be reported in the boring log.

Count the number of blows for each 150-mm (6-in.) increment of penetration until the sampler has penetrated 450 mm (18 in.) into the soil at the bottom of the borehole or until refusal has occurred. Refusal is defined as the condition when 50 blows have been applied during any one of three 150-mm (6-in.) increments of drive, a total of 100 blows has been applied to the sampler, or when there is no observed advance of the sampler during the application of 10 successive blows of the hammer.

Record the number of blows for each 150-mm (6-in.) increment of penetration or fraction thereof. If the sampler is driven less than 0.45 m (18 in.), the number of blows for each partial increment should be recorded. For partial increments, the depth of penetration should be reported to the nearest 25 mm (1 in.). Cite the reason(s) for terminating the test.

It should be noted that the first 150 mm (6 in.) of drive is considered to be a seating drive. The sum of the blows required for the second and third 150-mm (6-in.) increments of penetration is termed the "standard penetration resistance" or the "N value."

c. Withdrawal of the sampler from the borehole. For many drilling and sampling operations, the sampler may be withdrawn by pulling the line attached to the hammer. This action will cause the hammer to be raised against the top of the drivehead assembly and lift the entire hammer assembly,

sampling rods, and split-barrel sampler from the bottom of the borehole. If this method of extracting the sampler from the bottom of the borehole is unsuccessful or the sampler is extremely difficult to withdraw, several short, light, upward strokes of the hammer will drive the sampler upward. When the sampler is free, the entire string can be withdrawn from the borehole.

G-5. Factors Which Influence Penetration Data

Recently conducted research has identified a number of factors which could affect SPT blowcount data. Although the effects of several of these factors have been investigated and SPT procedures have been standardized as a result of the studies, a number of variables have not yet been investigated and/or standardized. Because the effects of these variables may be quantitatively, and for some cases qualitatively unknown, this discussion is intended to inform the drill rig operator as well as the geotechnical engineer of potential errors or sources of errors which could affect the SPT blowcount data. If the practitioner is aware of this information, it is believed that some of the uncertainty of the use and interpretation of SPT data can be minimized.

Because of the uncertainty of the qualitative and/or quantitative effects of many of the variables which could influence the SPT blowcount data, it is recommended that standard procedures should be followed and practiced. All pertinent data with respect to test conditions and equipment should be recorded. If differences of test results are identified for "identical" site conditions during the analyses and interpretation of the data, perhaps the discrepancy or error could be explained by arguments such as the condition of the equipment, or differences of equipment, procedures, or weather conditions.

a. Schmertmann's study. Schmertmann (1978) identified a number of factors which could influence the SPT blowcount data. These factors included penetration interval, sampling tube design, the number of turns of rope on the cathead, variations of drop height of the hammer, energy delivered to the sampling spoon, and the in situ effective stress condition. He also estimated the effects of the respective factors on the magnitude of the potential error on the SPT blowcount data. A brief discussion of the effects of these variables on SPT data is presented below.

(1) *Penetration interval.* The blowcount data should be recorded for each of three consecutive 150-mm (6-in.) increments of drive of the sampling spoon after the sampling tube has been seated in virgin material by one blow of the hammer. The SPT blowcount, N , is the sum of the number of blows for the depths of penetration from 150 to 300 mm (6 to 12 in.) and 300 to 450 mm (12 to 18 in.). Schmertmann suggested that the wrong sampling interval, such as 0 to 150 mm (0 to 6 in.) plus 150 to 300 mm (6 to 12 in.), could introduce an error of blowcounts, N , on the order of 15 to 30 percent.

(2) *Sampling tube design.* The physical dimensions of the split spoon could affect the SPT blowcount. For example, the use of a liner in the sampling tube would cause an increase of the blowcount as compared to the use of the same sampling tube without a liner. Schmertmann estimated that the use of a larger diameter sampling tube without a liner could cause a reduction of the penetration resistance on the order of 10 to 30 percent.

(3) *Number of turns of rope on the cathead.* Rope which is wrapped around the cathead may seriously impede the fall of the hammer. Consequently, the energy which is delivered to the anvil could be significantly less than the theoretical value computed for a free-fall condition. To minimize the potential differences of SPT blowcount data caused by the friction between the cathead and the rope, only two turns of the rope around the cathead should be used. It should be noted that the actual number of turns is approximately 1-3/4 for counterclockwise rotation of the cathead or 2-1/4 for clockwise

rotation of the cathead. Schmertmann estimated that the error caused by friction between the rope and the cathead could increase the blowcount data by as much as 100 percent.

(4) *Variation of drop height of hammer.* With other factors constant, the energy which is delivered to the anvil by the hammer is proportional to the free-fall distance of the hammer. Therefore, care is necessary to ensure that the drop of the hammer is constant. The standard procedure specifies that the height of the drop is 76 cm (30 in.). Schmertmann estimated that the error caused by an incorrect drop distance was approximately ± 10 percent.

(5) *Energy delivered to sampling spoon.* The length of the drill rods, the section modulus of the rods, and the mass of the anvil may affect the energy which is transferred to the drill rods and delivered to the sampling spoon. Schmertmann suggested that use of a large anvil as compared to a small anvil could increase the blowcount by as much as 50 percent. With respect to the length of the drill string, Schmertmann estimated that the blowcount could be 50 percent too high for short sections, i.e., less than 3 m (10 ft), of drill rods. Likewise, he estimated that an error on the order of about 10 percent could be caused by using an excessively long drill string. Schmertmann based his comparison on a section of drill rod which ranged from 9 to 24 m (30 to 80 ft) in length.

(6) *Effective stress condition.* The SPT blowcount data may be affected by the change of effective stresses in the sampling zone. The effective stress condition at the bottom of a borehole is dependent on the diameter of the borehole, the use of drilling mud as compared to casing, or the use of the hollow-stem auger as compared to casing and water. Schmertmann recommended the use of drilling mud in the borehole to minimize the change of effective stresses in the borehole.

b. *ASTM guidance.* The American Society for Testing and Materials (1993) published a list of factors which could effect penetration resistance in ASTM D 1586-84. It was reported that the use of faulty equipment, such as a massive or damaged anvil, a rusty cathead, a low-speed cathead, an old and/or oily rope, or massive and/or poorly lubricated rope sheaves could contribute significantly to differences of N values obtained between different operators or drill rig systems. ASTM reported that variations on the order of 100 percent or more had been observed for different apparatus or drillers for adjacent borings in the same formations. For the sake of comparison of the data, ASTM reported that for the same driller and sampling apparatus, the coefficient of variation was about 10 percent. To reduce the variability of blowcount data produced by different drill rigs and operators, ASTM suggested that the hammer energy which was delivered into the drill rods from the sampler should be measured and an adjustment of the blowcount data could be made on the basis of comparative energies.

c. *Guidance by the ICSMFE.* The International Committee on Soil Mechanics and Foundation Engineering International Reference Test Procedure for SPT (Decourt et al. 1988) identified several variables which could influence the SPT blowcount. Variables included unacceptable disturbance during preparation of the borehole, failure to maintain sufficient hydrostatic head in the borehole which could result in the flow of soil into the borehole, disturbance caused by overboring or overdriving of casing, the omission of liners which would reduce the penetration resistance, energy transmitted to the rods which was dependent on the shape of the hammer and the number of turns of rope on the cathead, and a large steel drivehead which could increase the penetration resistance because of a decrease of energy transmitted to the rods. Also of interest was the statement that there were "no significant differences in blowcounts or energy transferred for rods weighing 4.33 to 10.03 kg/m" (2.9 to 6.7 lb/ft). It should be noted that rods weighing 4.33 to 10.03 kg/m (2.9 to 6.7 lb/ft) compare to AX and NX rods. One other important statement was also noted: "...the energy input definition has not been proposed because of the lack of experience and the possibility of its becoming part of a 'test' routine rather than the intention

solely for 'equipment' calibration....” Although this statement appears to conflict with the procedure recommended by ASTM, the decisions regarding the calibration of drilling and sampling equipment should be made by the engineer in charge following the official guidance from the Department of the Army, U.S. Army Corps of Engineers. If official guidance is unavailable, the boring logs should contain information about the hammer energy and how the energy or efficiency was obtained.

d. Studies reported by other researchers. Other researchers have identified additional factors which could influence penetration resistance. Riggs (1986) identified several factors which could affect SPT N values but were missing in ASTM D 1586-84. The factors included requirements on hammer and anvil dimensions, mass and diameter of the rope sheaves, derrick height, and alignment or configuration of the cathead and crown sheaves. Studies reported by Kovacs and Salomone (1982) indicated the number of wraps of rope on the cathead, the drop height, the drill-rig type, hammer type, and operator characteristics influenced the energy delivered to the drill stem.

G-6. Sampling Records and Preservation of Samples

After the sampler has been removed from the borehole and detached from the drill rods, the sampling spoon can be disassembled and the soil in the sampling spoon can be examined. If there is soil within the sampler, record the length of the sample recovered or the percent recovery. Describe the soil. Note the location of each stratum with respect to the bottom of the sampler barrel. Place a representative portion of each stratum into a waterproof container (jar) without ramming or distorting any apparent stratification. One or more containers may be used, as necessary. Seal each jar to prevent evaporation of soil water. Affix a sample label to each container. Include information on the label, such as project number or site, borehole number, sample number and depth, description of the soil, strata changes within sample, sampler penetration and recovery lengths, number of blows per 150 mm (6 in.) or partial increment, and date of sampling. Protect the samples from temperature extremes.

All pertinent borehole data, penetration resistance, and sample data must be recorded on a boring log data sheet similar to the data presented in Figure G-5. The depths at the top or bottom of each 150-mm (6-in.) increment of sampler penetration along with the number of blows required to effect that segment of penetration should be reported. Clear and accurate information is required for definition of the soil profile, depths of penetration of the sampler, penetration resistance, and location of the sample. Other information which may contribute to a more accurate estimate of the condition of the samples and physical properties of the in situ soil should also be noted.

The following information is presented as a checklist of data which should be recorded in the field:

- Name and location of the job.
- Names of crew.
- Type and make of drilling machine.
- Weather conditions.
- Date and time of start and finish of boring.
- Boring number and location. Give station or coordinates, if available.

- Surface elevation, if available.
- Method of advancing and cleaning the borehole.
- Method of keeping the boring open.
- Size of casing and depth of cased portion of boring, if used.
- Depth to base of casing with respect to depth of sampling.
- Equipment and method of driving sampler.
- Type of sampler. Include its length and inside diameter. Note if liners or sample retainers were used.
- Size, type, and length of sampling rods.
- Type of hammer and release mechanism or method.
- Height of free-fall of the hammer.
- Depth to bottom of borehole before test, depth of initial penetration, depth of split-barrel sampler after seating blow(s) have been applied, and depth after each 150-mm (6-in.) increment of penetration has occurred.
- Penetration resistance (blowcount data) for each 150-mm (6-in.) increment of penetration.
- Sample number/depth.
- Sample depth: top and bottom.
- Sampler penetration and recovery lengths.
- Description of soil. Include strata changes within the sample.
- Date of sampling.
- Obtain complete groundwater information. Include the groundwater level or elevation before the drilling and sampling operations begin, groundwater level or drilling fluid level at the start of each test, depth at which drilling fluid was lost or artesian water pressure was encountered, and time and date of each annotation. After the drilling and sampling operations have been completed, record the groundwater level in sands at least 30 min after boring was completed; in silts, record groundwater data after 24 hours (hr); in clays, record data after 24 hr and at a later time, if possible. If groundwater was not encountered, so indicate.
- Record pertinent observations which could assist in the interpretation of data, i.e., stability of strata, obstructions, etc.
- Record calibration results, where appropriate.

G-7. Interpretation of SPT Blowcount Data

Although the purpose of this manual is not to provide guidance for interpretation of SPT data for engineering purposes, the data in Table G-1 can be used by the inspector for describing the in situ soil conditions as determined by the SPT. These data have been referenced throughout the world and have been scrutinized by the engineering profession for one-half century. Furthermore, the data in Table G-1 are not significantly different from those data in EM 1110-1-1905, which presents the official guidance for interpretation of SPT blowcount data.

Specifically, EM 1110-1-1905 states that the SPT blowcount, N , should be normalized to an equivalent blowcount, N_{60} , which is the effective energy delivered to the drill rod at 60 percent of the theoretical free-fall energy. The blowcount correction factors are dependent upon the effective overburden pressure, the hammer release mechanism, and the type of hammer, i.e., donut or safety, etc. According to the data in EM 1110-1-1905, the rod energy factor varies from less than 0.8 to slightly greater than 1.0. It should be noted, however, that a number of researchers have reported that the measured energy delivered to the rods by SPT hammer/release systems were typically 40 to 55 percent of the theoretical free-fall energy; these lower values of energy delivered to the rods by SPT hammer/release systems explain the selection of the equivalent blowcount, N_{60} , as compared to a higher value for the energy factor, as inferred by the data in EM 1110-1-1905.

Table G-1
Soil Density or Consistency from Standard Penetration Test Data (after Terzaghi and Peck 1948)

| Consistency | <u>Cohesive Soil</u> | |
|-------------|-----------------------|----------------------------------------------|
| | Blows/foot (0.3048 m) | Unconfined Compressive Strength ¹ |
| Very soft | Less than 2 | Less than 25 kPa (0.25 tsf). |
| Soft | 2 to 4 | 25 to 50 kPa (0.25 to 0.5 tsf) |
| Medium | 4 to 8 | 50 to 100 kPa (0.5 to 1.0 tsf) |
| Firm | 8 to 15 | 100 to 190 kPa (1.0 to 2.0 tsf) |
| Very firm | 15 to 30 | 190 to 380 kPa (2.0 to 4.0 tsf) |
| Hard | Greater than 30 | Greater than 380 kPa (4.0 tsf) |

| <u>Cohesionless Soil</u> | |
|--------------------------|-----------------------|
| Density | Blows/foot (0.3048 m) |
| Very loose | Less than 4 |
| Loose | 4 to 10 |
| Medium dense | 10 to 30 |
| Dense | 30 to 50 |
| Very dense | Greater than 50 |

¹ The unconfined compressive strength may be approximated by the pocket penetrometer or the vane shear apparatus.

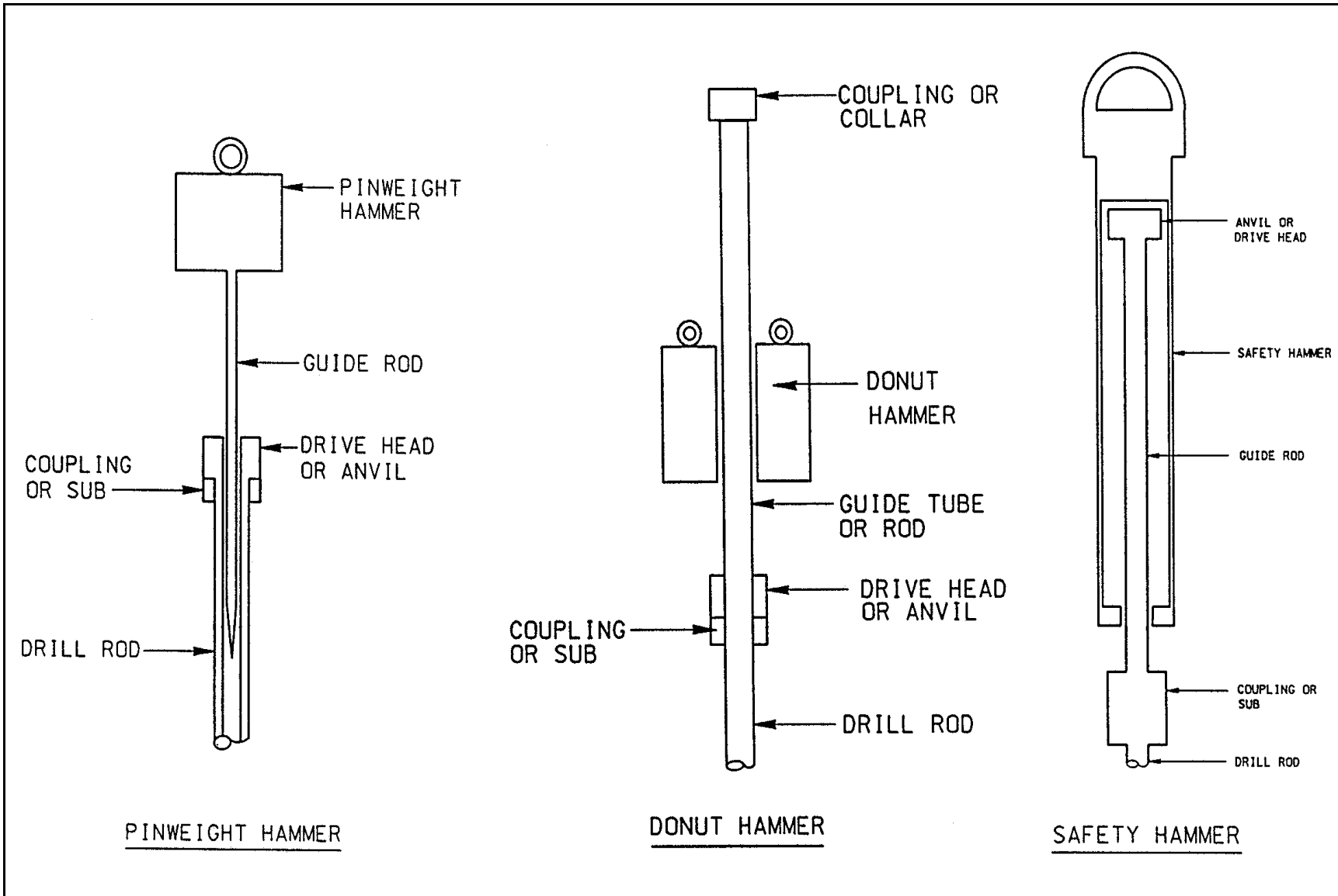

Figure G-1. Schematic drawing of the pinweight hammer, the donut hammer, and the safety hammer (after Riggs 1986)

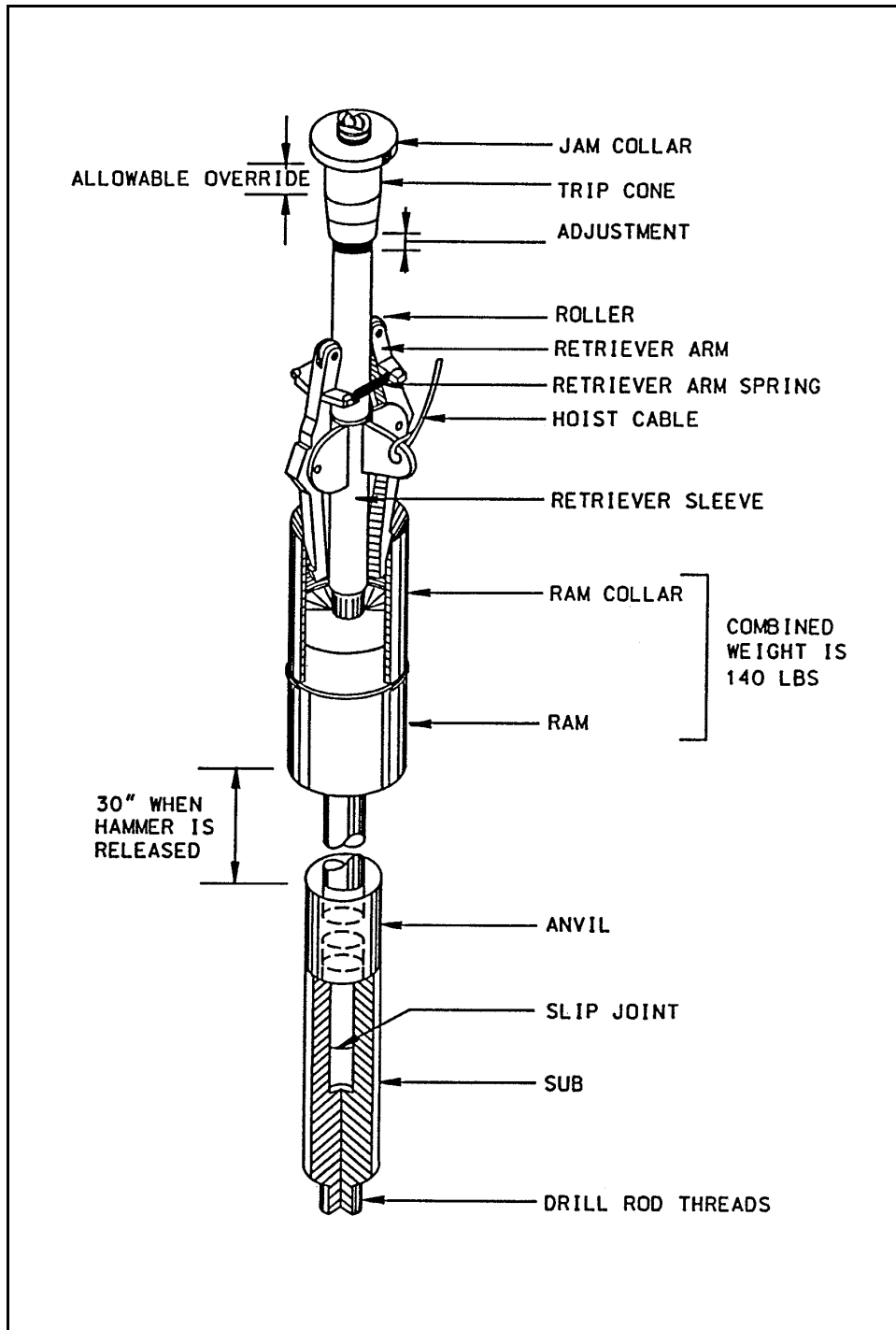

Figure G-2. Schematic drawing of the automatic trip hammer

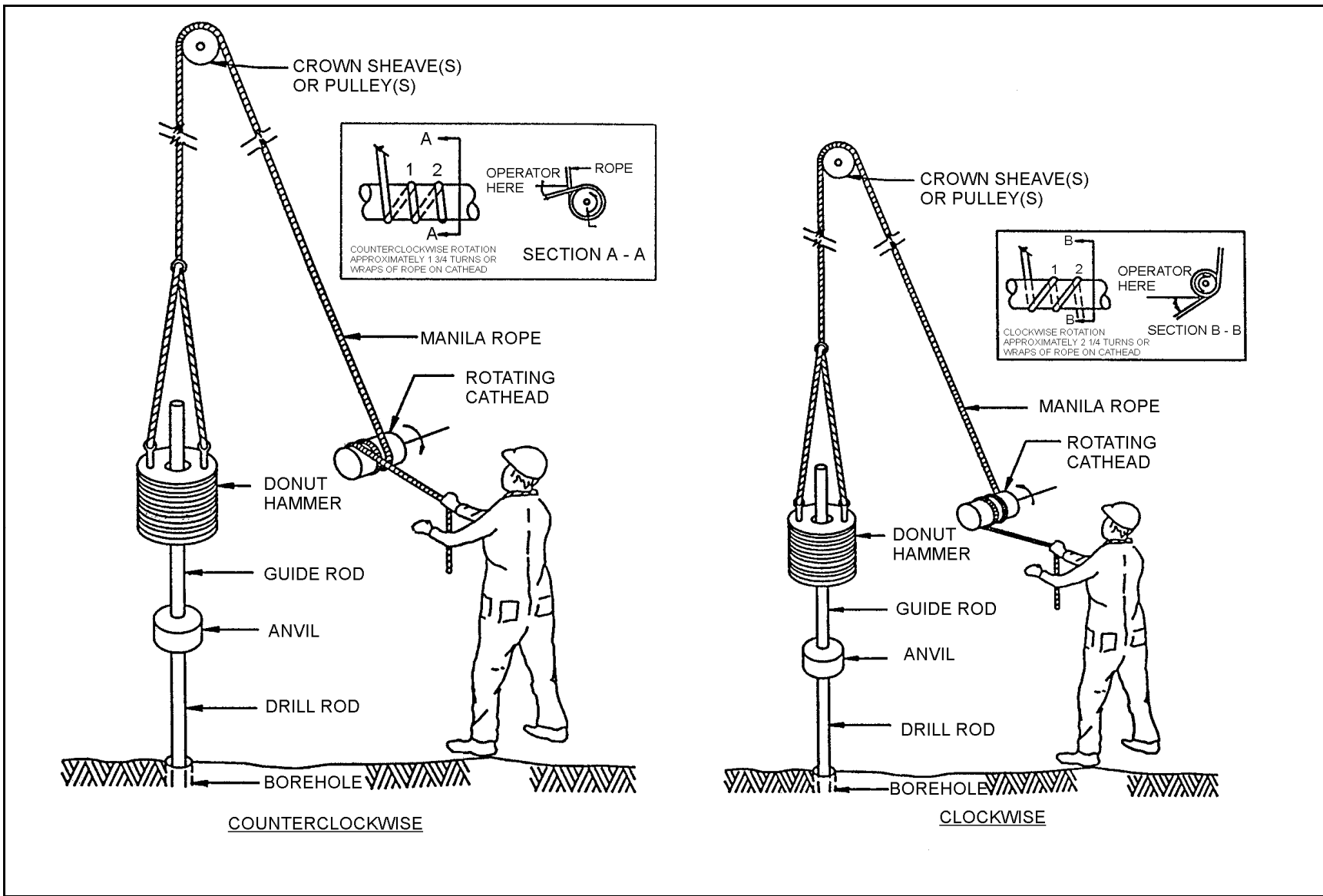

Figure G-3. Schematic drawing of the number of turns of rope on the cathead; 1-3/4 for counterclockwise rotation of the cathead, and 2-1/4 turns for clockwise rotation of the cathead

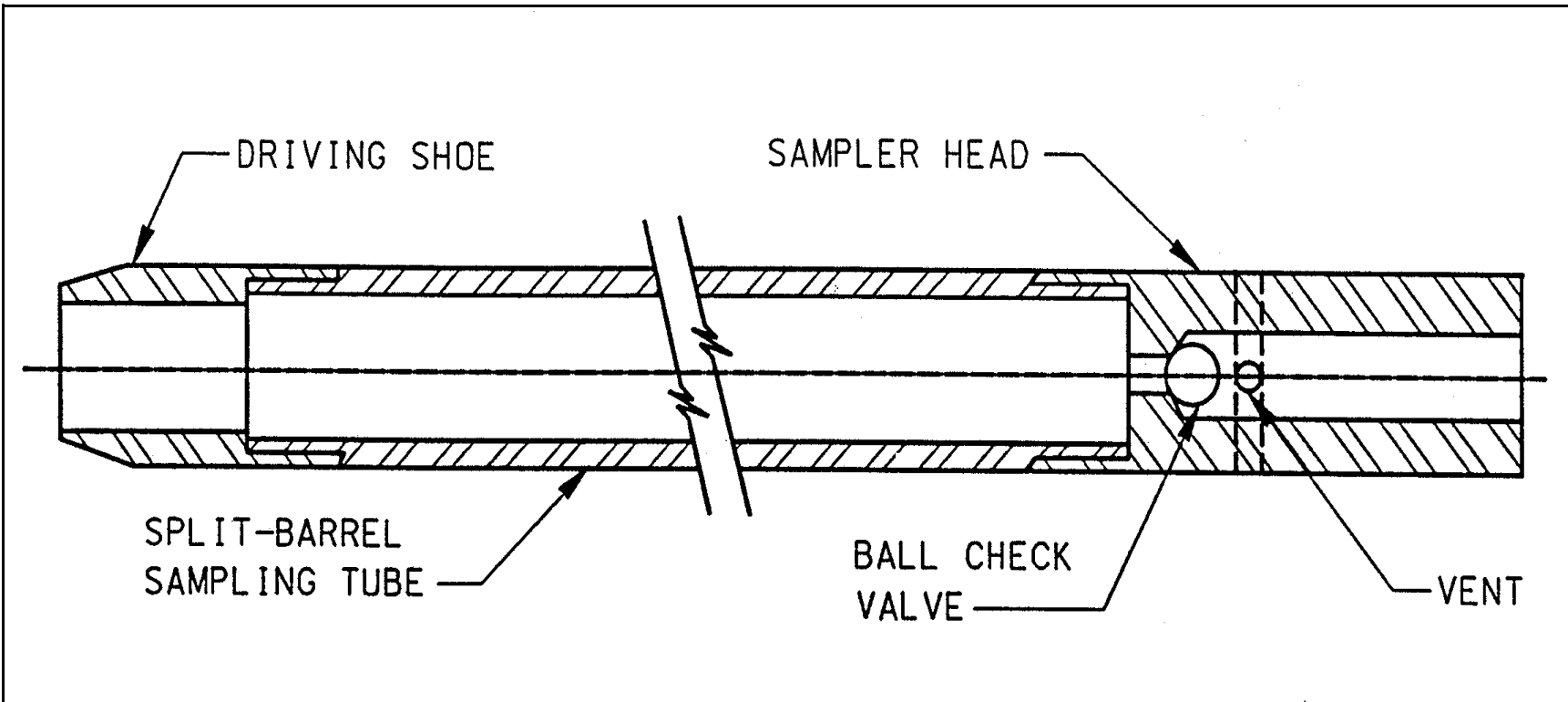

Figure G-4. Schematic drawing of the split-barrel sampler

BORING LOG
FIELD DATA

Project Morville Revetment Location Range 2, Riverside 400' Date 8 June, 1971
 Drill Rig W-4048 Inspector Elliot Operator Brown Surface elev 580ft. MSL
 Levee District Concordia Job No. 7063 Boring No. MR-1

| SAMPLE NUMBER | DATE TAKEN | STRATUM | | DRIVE | | SAMPLE | | TYPE OF SAMPLER | CONTAINER | HYDRAULIC PRESSURE OR BLOWS | CLASSIFICATION AND REMARKS |
|-----------------------------------------------------------------------------------|------------|---------|------|-------|------|--------|------|---------------------|-----------|-----------------------------|----------------------------|
| | | FROM | TO | FROM | TO | FROM | TO | | | | |
| - | 8 June | 0.0 | 11.5 | 0.0 | 12.0 | - | - | 6" Fishtail | - | - | Brown silty clay, stiff CL |
| 1 | 8 June | 11.5 | | 12.0 | 12.5 | 12.4 | 13.2 | * Splitspoon | Jar | 7 | Gray sand, fine SP |
| | | | | 12.5 | 13.0 | | | | | 10 | |
| | | | | 13.0 | 13.5 | | | | | 15 | |
| | | | | 13.5 | 14.0 | - | - | 4" Baffled Fishtail | - | - | Gray sand, fine SP |
| | | | 14.3 | | | | | | | | |
| 2 | 8 June | 14.3 | | 14.0 | 14.5 | 14.5 | 15.3 | Splitspoon | Jar | 8 | Gray sand, med. SP |
| | | | | 14.5 | 15.0 | | | | | 10 | |
| | | | | 15.0 | 15.5 | | | | | 16 | |
| Boring Complete at 15.5 Ft. depth | | | | | | | | | | | |
| * 2" OD x 1 3/8" ID x 2 ft. long splitspoon driven with 140-lb. hammer w/30" drop | | | | | | | | | | | |

WES FORM NO. 819
REV FEB 1971

Sheet 1 of 1 Sheets

Figure G-5. Log of a penetration resistance boring with typical information which must be recorded

Appendix H (*Appendix C of EM 1110-1-1906*) Penetration Resistance Testing with the Becker Hammer Drill

H-1. Introduction

The use of the Becker hammer drill as an in situ penetration test for gravelly soils has gained widespread acceptance since its use was first reported (Harder and Seed 1986).¹ The Becker Penetration Test (BPT) for gravelly soils has become synonymous to the Standard Penetration Test (SPT) for sandy soils. However, the technology on use of the BPT for assessing engineering parameters is still evolving. The information presented herein is not the “how to do” cookbook approach, but rather it is a synopsis of the test procedures which are currently accepted and used as well as a list of variables that may affect the test results. Because standard procedures for conducting the BPT do not exist, it is recommended that the geotechnical engineer and/or the engineering geologist should peruse the literature and communicate with individuals knowledgeable on the use of the BPT prior to planning and conducting an investigation with the Becker hammer drill.

H-2. Equipment

The Becker hammer drill was devised specifically for use in sand, gravel, and boulders by Becker Drilling, LTD., of Canada. The drill utilizes a diesel-powered pile hammer to drive a double-wall casing into the ground without rotation. The elements of the Becker hammer drill include an air compressor, mud pump, a double- or single-acting diesel-powered hammer, rotary drive unit, hydraulic hoist, casing puller, mast, and cyclone. The double-wall threaded casing is specially fabricated from two heavy pipes which act as one unit. The casing has flush joints and tapered threads for making and breaking the string. Standard casings vary from 14.0- to 23-cm (5.5- to 9.0-in.) OD; the 17-cm- (6.6-in.-) diam casing is commonly used for the BPT. A toothed bit which is attached to the casing is used to break the material at the bottom of the borehole.

H-3. Sampling and Testing Procedures

Either an open bit or a plugged bit can be used to drive the casing. The BPT is conducted with a plugged bit, as experience has shown that questionable values of penetration resistance may be obtained if the open bit is used. To conduct the BPT, the number of hammer blows to drive the casing 0.3 m (1 ft) is counted and recorded. To use the BPT data, the blowcounts are converted to equivalent SPT blowcounts by empirical correlations (Harder and Seed 1986). From the equivalent SPT blowcounts, the penetration resistance can be correlated to selected geotechnical engineering parameters, such as liquefaction potential (Seed, Idriss, and Arango 1983; Seed et al. 1985).

The open bit is used for obtaining disturbed samples by the reverse circulation technique. As compressed air is pumped to the bottom of the hole through the annular space between the two pipes, broken fragments or cuttings are returned to the surface through the center of the casing. At the surface, the return flow is collected by a cyclone or collector buckets. The cuttings can be observed to give an idea of the materials which have been drilled. The sample should be interpreted cautiously, as it is a mixture of all soil materials from a given depth interval. If necessary, drilling can be stopped, and sampling can be conducted through the inner barrel using a split-barrel sampler or coring techniques. Procedures for documenting the results of the BPT (including sampling records and preservation of samples, if obtained) should follow the procedures which are described in Chapter 13.

H-4. Factors Which Affect the Becker Penetration Test

Harder and Seed (1986) initially believed that the bounce chamber pressure was a measure of the energy which was delivered to the penetrometer (casing). Upon further investigation, they determined that BPT blowcounts could not be predicted for different bounce chamber pressures. They determined that the energy which was developed was dependent on such factors as the combustion efficiency and conditions of the diesel hammer, atmospheric pressure, and the material response (including density, gradation, and overburden pressure) of the soil being penetrated.

Harder and Seed reported that the combustion efficiency was operator dependent. They reported that the operator could vary the throttle on the diesel hammer. They also found that the use of a rotary blower which forced air into the combustion cylinder resulted in a better burn (higher efficiency) of the fuel. Harder and Seed reported that the energy which was produced was dependent on combustion conditions, including fuel quantity and quality and the air mixture and pressure. For example, they suggested that the BPT could vary from 14 to 50 or more blows in the same material at the same depth if different combustion efficiencies were used. Hence, they concluded that the BPT had to be conducted under standard combustion conditions.

With respect to the effects of different atmospheric pressures, Harder and Seed reported that the energy which was delivered to the penetrometer (plugged bit) was a function of the pressure in the bounce chamber. For different atmospheric pressures, different bounce chamber pressures will result for the same hammer energy. Consequently, the measured bounce chamber pressures must be corrected for atmospheric conditions, especially when drilling operations are conducted at different elevations. To account for the effects of atmospheric pressures, Harder and Seed suggested that a ratio of theoretical impact kinetic energies for different atmospheric conditions could be used to normalize differences of delivered energies.

Harder and Seed also noted that the energy which was developed in the bounce chamber (blowcount) was dependent on the soil being penetrated. For low blowcount materials, the displacement of the casing was relatively large for each blow; much of the energy from the expanding combustion gases was lost to casing movement rather than raising the driving ram. As the blowcounts increased, Harder and Seed determined that more of the energy in the combustion chamber was transferred to the hammer; consequently, more energy was available to drive the penetrometer. Because of these findings, they suggested that a family of curves, i.e., site-specific correlations, should be developed for a given drill rig and hammer to account for differences of bounce chamber pressures on BPT blowcount.

H-5. Summary

The BPT is a nonstandard test for which technology is evolving. Although BPT data must be adjusted to account for the effects of atmospheric conditions, material response, and overburden, the BPT blowcounts should be obtained using constant combustion conditions to the maximum extent possible. To interpret the test results and to use the penetration data for engineering purposes, Harder and Seed recommended that the adjusted BPT blowcounts should be converted to equivalent SPT blowcounts using empirical BPT-SPT correlations. The equivalent SPT blowcounts should then be normalized for the effects of overburden prior to correlating the equivalent blowcount data to the desired engineering parameters.

Although the BPT appears to be laden with numerous problems for conducting the test as well as interpretation of the data, the BPT is one of a very few in situ tests which can be used for assessing the

engineering parameters of gravelly soils. (Geotechnical personnel are reminded that the SPT is used worldwide as an in situ test for sandy soils, although a number of variables which are discussed in Appendix B may affect the SPT results.) The principal advantage of the Becker hammer drill is that it offers a rapid and inexpensive method for drilling gravelly and bouldery materials. A principal disadvantage of the BPT test is that the in situ stress conditions may be altered significantly during the drilling process. For example, the flow of groundwater into the borehole can disturb the material at the bottom of the boring. Likewise, sand surrounding a boulder at the bottom of the borehole may be sucked into the casing as the hammer drilling is conducted; the results would be a nonrepresentative sample and a recovery ratio in excess of 100 percent.